

Yale YK Wire Rope Hoist

Top-Running Hoist and Trolley

Customer Name: QUOTATIONS CUSTOMER
 Quote Number: 8953S, Line: 1
 Revision Number: 1
 Quote Date: 4/30/2020

TECHNICAL DATA

Hoist Platform	GN Wire Rope Hoist
Hoist Model Number	YKC-T15-033S413-2-78
Rated Lift Capacity	15 U.S. tons
Maximum Lift Distance	33 ft (10.1 m)
Maximum Lifting Speed	13 ft/min (3.96 m/min)
Reeving Style	4-Part Single-Reeved
Hoist Control Type	Two-Speed
Hoist Suspension Type	Top Running Low Profile
Bridge Rail Size Min. (lb/yd)	25#
Bridge Rail Size Max.	40#
Trolley Traverse Speed (60Hz)	80 ft/min (24.38 m/min)
Trolley Control Type	Two-Speed
Trolley Bumpers	Included
Hoist Duty Classification	HMI Class H4
Operating Voltage	460V / 3ph / 60Hz
Control Voltage	120 VAC
Trolley Motor HP	2.0
Trolley Motor Qty	1
Base Weight of Hoist (lbs)	2194.71

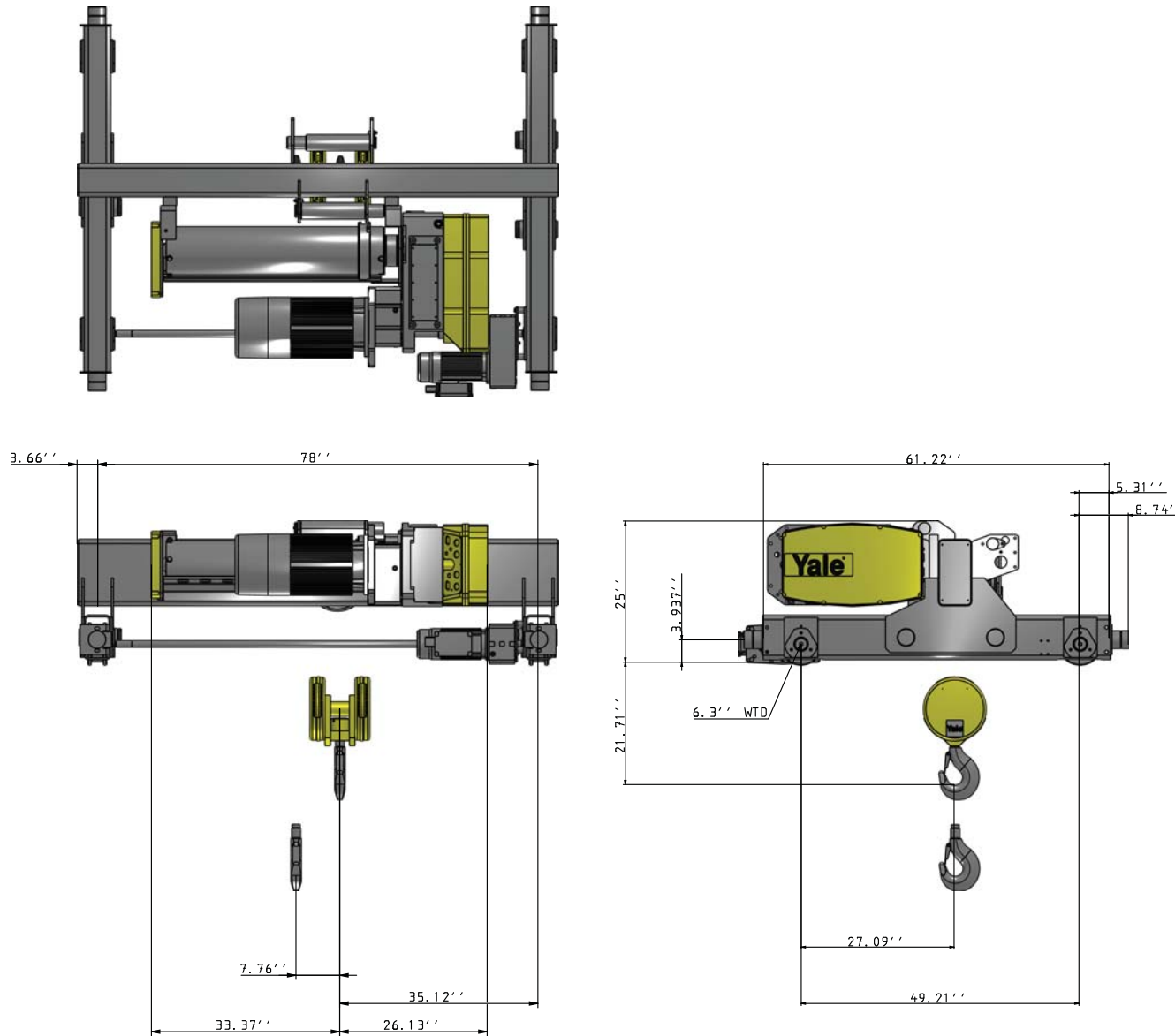

This document was generated by COMPASS®
 by Columbus McKinnon Corporation
 Getzville, New York USA

This drawing is intended for preliminary reference use only and depicts general clearance dimensions based on standard product configuration. If your application includes specific critical dimensional constraints it is recommended that an Approval Drawing be requested at time of order.

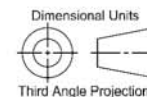

Yale YK Wire Rope Hoist

Top-Running Hoist and Trolley

Technical Data & Specifications

Hoist Platform	GN Wire Rope Hoist
Hoist Model Number	YKC-T15-033S413-2-78
Brand	Yale
Rated Lift Capacity	15 U.S. tons
Maximum Lift Distance	33 ft (10.1 m)
Hoist Suspension Type	Top Running Low Profile
Reeving Style	4-Part Single-Reeved
Hoist Duty Classification	HMI Class H4
Operating Voltage	460V / 3ph / 60Hz
Control Voltage	120 VAC
Maximum Lifting Speed	13 ft/min (3.96 m/min)
Hoist Control Type	Two-Speed
Hoist VFD Type	N/A
Secondary Lift Speed	2 ft/min (0.610 m/min)
Hoist VFD Step Frequencies	N/A
Trolley Traverse Speed (60Hz)	80 ft/min (24.38 m/min)
Trolley Control Type	Two-Speed
Trolley VFD Type	N/A
Secondary Traverse Speed	20 ft/min (6.10 m/min)
Trolley VFD Step Frequencies	N/A
Trolley Wheel Tread Style	Straight
Trolley Wheel Material	Ductile Iron 240 BHN
Bridge Rail Size Min. (lb/yd)	25#
Bridge Rail Size Max.	40#
Hoist Motor (Main) HP	14.8
Hoist Brake Type	DC Single Brake
Trolley Motor HP	2.0
Trolley Motor Qty	1
Trolley Traverse Drive Brake	Included (IP55 Rated)
Trolley Drop Stops	Included
Trolley Drop-Stop Material	Steel
Trolley Bumpers	Included
Trolley BUMPER Size	Rubber BUMPER, Size 80
Block Operated Limit Switch	Included
Geared Limit Switch Style	4 Element Rotary Geared
Rope Guide(s)	Included