

Yale YK Wire Rope Hoist

Top-Running Hoist and Trolley

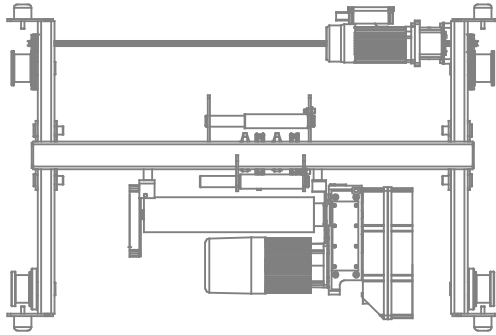

CATALOG DRAWING - NOT TO SCALE. MAY NOT ACCURATELY REFLECT THE ACTUAL PRODUCT CONFIGURATION

Accurate CAD models of the configured product are available in both 2D and 3D versions.

Customer Name: QUOTATIONS CUSTOMER
 Quote Number: PVC8B, Line: 1
 Revision Number: 1
 Quote Date: 3/31/2020

TECHNICAL DATA

Hoist Platform	GN Wire Rope Hoist
Hoist Model Number	YKA-T02-020S420-2-48
Rated Lift Capacity	2 U.S. tons
Maximum Lift Distance	20 ft (6.1 m)
Maximum Lifting Speed	20 ft/min (6.1 m/min)
Reeving Style	4-Part Single-Reeved
Hoist Control Type	Two-Speed
Hoist Suspension Type	Top Running Low Profile
Bridge Rail Size Min.	25# (lb/yd)
Bridge Rail Size Max.	40# (lb/yd)
Trolley Traverse Speed (60Hz)	80 ft/min (24.38 m/min)
Trolley Control Type	Two-Speed
Trolley Bumpers	Included
Hoist Duty Classification	H4+
Operating Voltage	460V / 3ph / 60Hz
Control Voltage	120 VAC
Trolley Motor HP	0.6
Trolley Motor Qty	1
Base Weight of Hoist	681.345 (lbs.)

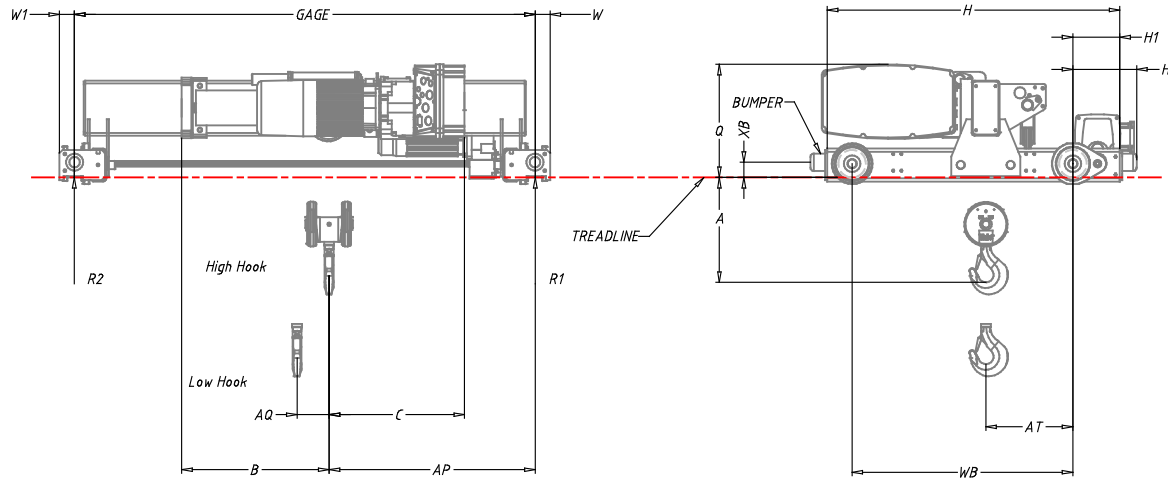

DIMENSIONAL DATA

A	14.96 INCH	AP	20.53 INCH
B	21.03 INCH	AQ	4.57 INCH
C	19.307 INCH	AT	12.44 INCH
H	41.734 INCH	W	2.17 INCH
H1	6.693 INCH	W1	2.165 INCH
HE	9.1 INCH	WB	31.5 INCH
Q	16.13 INCH	WTD	3.937 INCH
Gage	48 INCH	XB	2.17 INCH

This document was generated by COMPASS®
 by Columbus McKinnon Corporation
 Getzville, New York USA

This drawing is intended for preliminary reference use only and depicts general clearance dimensions based on standard product configuration. If your application includes specific critical dimensional constraints it is recommended that an Approval Drawing be requested at time of order.

