

TELEMOTIVE

APPENDIX F

10K Stepless

Electronic Transfer Switch



Material Handling Group

N49 W13650 Campbell Drive
Menomonee Falls, WI 53051
Phone: 800-288-8178 Fax: 262-783-3510
Website: www.telemotive.com

Appendix F –10K Electronic Transfer Switch (Continued)

This page intentionally left blank.

Appendix F – 10K Electronic Transfer Switch (Continued)



WARNING

BEFORE OPERATING THE TRANSMITTER FAMILIARIZE YOURSELF WITH ALL SAFETY INFORMATION IN THIS MANUAL, THE CORRESPONDING 10K SYSTEM MANUAL (TC10KMOD-0), APPROPRIATE MANUAL SUPPLEMENTS AND ANY OTHER LOCAL, STATE, OR FEDERAL RULES OR REGULATIONS ALREADY IN EXISTENCE. FAILURE TO FOLLOW THIS WARNING COULD RESULT IN SERIOUS INJURY OR DEATH AND DAMAGE TO EQUIPMENT.

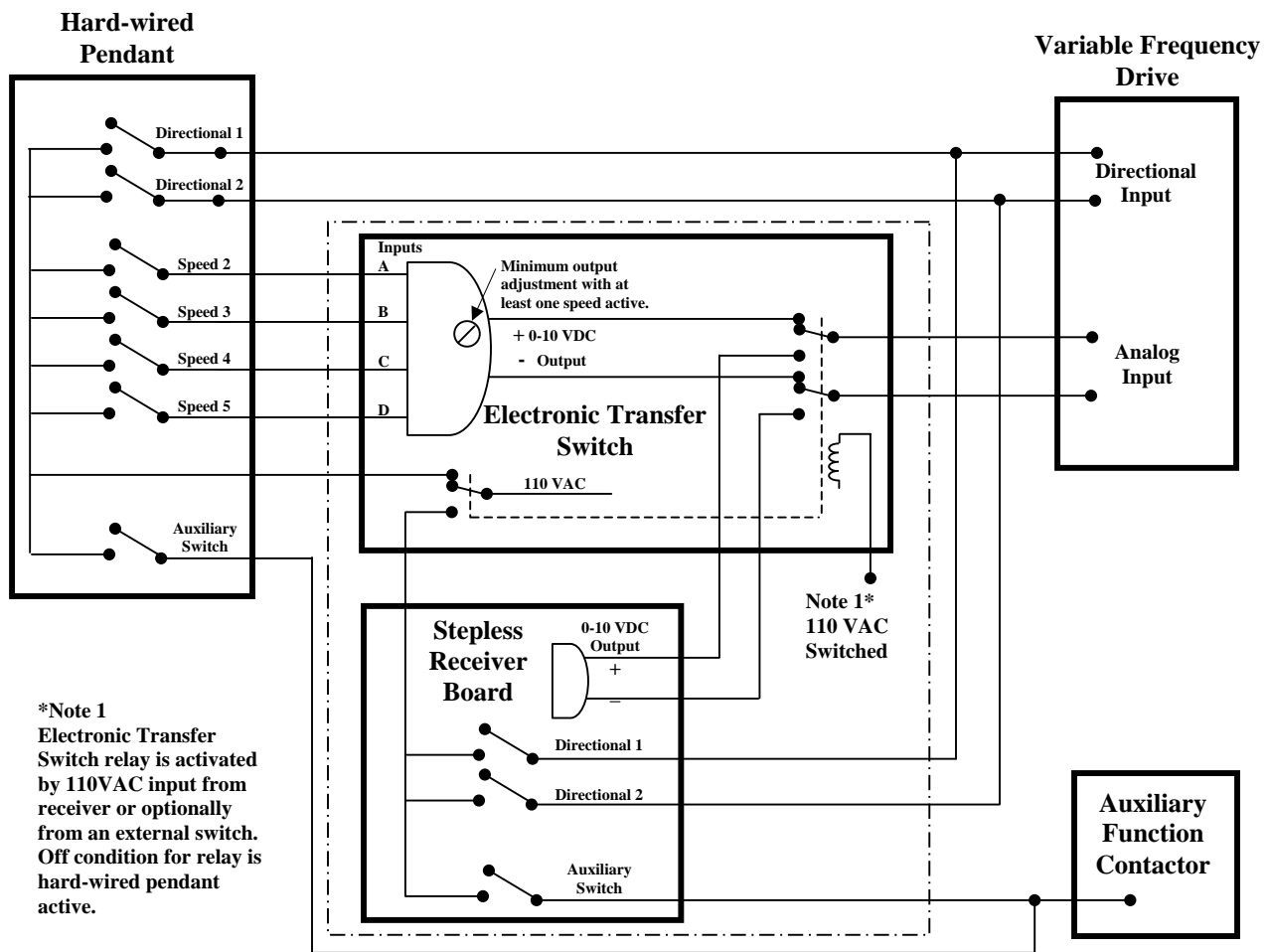

Figure F-1. Electronic Transfer Switch Block Diagram.

F-1. 10K Electronic Transfer Switch.

Sections F-1. through F-4. describe the functional operation of the 10K Electronic Transfer Switch. Please refer to Figure F-1. Electronic Transfer Switch Control Block Diagram for functional description.

F-2. 10K Electronic Transfer Switch Introduction.

Variable frequency drives (VFD's) typically have two types of inputs for speed control, hard contact switched inputs and 0-10 Volt DC continuously variable analog inputs. However,

Appendix F –10K Electronic Transfer Switch (Continued)

many VFD's will allow the use of only one type of inputs after the unit is programmed. Hard wired pendants need the hard contact switched inputs and the 10K Stepless product needs the 0-10 Volt DC input. A standard mechanical transfer switch will not work.

The electronic transfer switch works with the 10K Stepless product to allow true variable speed operation for the wireless pendant and up to 4 motors and 5 speeds on a hard-wired pendant using one common 0-10 Volt DC input to the VFD.

F-3. 10K Electronic Transfer Switch Description.

The electronic transfer switch takes the various steps of the hard-wired pendant and turns it into a 0-10 Volt DC signal. The actual voltage out or speed for each step of the hard-wired pendant is customer adjustable. Switching between hard-wired pendant and wireless remote control is accomplished by the application of 110VAC into the electronic transfer switch.

Also switched between the hard-wired pendant and the stepless receiver is the 110 VAC for the directionals and the auxiliaries. This allows the directional outputs and the auxiliary outputs from both the hard-wired pendant and the 10K stepless receiver to be wired in parallel respectively.

F-4. 10K Electronic Transfer Switch Operation.

The electronic transfer switch is designed for 110VAC through the hard-wired pendant up to the inputs. The directionals from the hard-wired pendant go directly to the VFD. Each line from the hard-wired pendant representing a speed step goes into an opto-isolated switching device on the electronic transfer switch board. The output of the switching device is a DC voltage, which is adjustable from 0-10 Volts. A relay for each motion is driven by the 110 VAC signal into the unit switches the between the output of the hardwired pendant and the analog output of the radio-controlled receiver.

Since the outputs of the hardwired pendant and the 10K stepless receiver for the both the directionals and auxiliaries are wired in parallel, switching for these functions between the hardwired pendant and the 10K stepless receiver

is controlled by the switching of the 110 VAC power between the 10K stepless controlling relays and the hard-wired pendant contacts.

F-5. Installation.

Sections F-5. through F-11. detail the installation and set up of the electronic transfer switch. Also refer to Table 1. for your appropriate model.



F-6. Programming.

No programming is required for the electronic transfer switch. The only adjustment required is to set the initial speed for the directional input and each voltage/speed for each step on the hard-wired pendant.

F-7. Wiring.

Figure F-2. Electronic Transfer Switch Board gives the connection detail for the Electronic Transfer Switch Board. Refer to Table 1. and the Stepless Receiver Manual for the specific wiring for your model of 10K Stepless Receiver. Please consult the manual for your VFD for proper wiring and hookup. If there is a conflict or a question about proper setup instructions between the VFD manual and these instructions please contact Telemotive.

The 10K stepless receiver, the directionals and the auxiliaries are wired directly to their respective boards. See the appropriate section of the 10K Stepless Receiver manual for specific connection locations.

Appendix F –10K Electronic Transfer Switch (Continued)



WARNING

THE UNIT SHIPS WITH THE WIRELESS TRANSMITTER SET AS PRIORITY. TURNING ON THE WIRELESS TRANSMITTER WILL AUTOMATICALLY DISABLE THE HARDWIRED PENDANT. TO DISABLE THIS FUNCTION CONSULT SECTION F-8 EXTERNAL SWITCHING BELOW. FAILURE TO FOLLOW THIS WARNING COULD RESULT IN SERIOUS INJURY OR DEATH AND DAMAGE TO EQUIPMENT.

F-8. Electronic Transfer Switch External Switching.

Switching between pendant and radio control is factory pre-wired for automatic upon radio receiver turn on by wireless transmitter.. To disable automatic switching use an external switch. See details in Table 1. for wiring up an external switch. Terminals are provided for an external switch. Current requirements are less than a quarter of an Amp. When using an external switch the connections X1 and X2 to the MR relay must be removed.



CAUTION

FOR THE ELECTRONIC TRANSFER SWITCH TO FUNCTION PROPERLY, ALL POWER TO THE HARD-WIRED PENDANT MUST COME FROM THE SWITCHED 110 VAC FROM THE ELECTRONIC TRANSFER SWITCH. FAILURE TO FOLLOW THIS CAUTION COULD RESULT IN DAMAGE TO, OR DESTRUCTION OF EQUIPMENT, OR LOSS OF FUNCTIONAL EFFECTIVENESS.

F-9. Hard-wired Pendant Wiring.

The hard-wired pendant directionals are to be wired directly to the directional inputs on the VFD. All power to the pendant must come from the switched 110 VAC from the electronic transfer switch. One of these switched 110 VAC

lines can be used to power the auxiliaries. All switch speed outputs must go to inputs A through D on the electronic transfer switch. Consult Table 1. for specific connections. Connections will vary depend on number of speed steps in switches.

The unit comes with all 110VAC feeds and commons to the pendant wired together. If separate transformers are used break the feeds and commons and wire individually as needed.

F-10. VFD Setup.

The unit must be fully wired before adjusting the speed. Please consult the manual for your VFD for proper adjustment and setup. If there is a conflict or a question about proper setup instructions between the VFD manual and these instructions please contact Telemotive. The VFD must first be properly programmed.

F-11. Speed Adjustment.

Follow Steps 1 through 5.

Step 1.

For a given motor set the speed range (minimum and maximum) for 0 and 10 Volts DC input respectively on the VFD for that motor.

Position 1, the first step (the directional output of the hard-wired pendant) should be connected to the appropriate directional input of the VFD. The engaging of the first hard-wired pendant position for the first speed will give the minimum speed programmed into the VFD.

Step 2.

Verify that the hard-wired pendant switch when fully engaged gives 10 Volts DC output to the VFD.

The final hard-wired pendant switch position is factory preset to 10Volts DC, this will give the max speed set in the VFD in Step 1. If it is not the adjustments R7, R28, R49, and R70 control the 10 Volts DC output for motors 1 through 4 respectively.

Step 3. (For switches with 3 or 5 positions only).

Engage the same hard-wired pendant switch to the second position. Set the appropriate 2nd Step

Appendix F –10K Electronic Transfer Switch (Continued)

Speed Adjustment R24, R44, R65, or R82 (motors 1 through 4 respectively, see Figure F-1.) to the proper voltage to give the desired speed from the motor at that position.

The additional speeds or hard-wired pendant switch positions (up to 3 more) are preset to be proportional between the settings of the second position and the final position.

Step 4.

Repeat steps 1 through 3 for each motor up to four motors.

Step 5.

With the area around the crane clear of personnel and obstructions engage the system and verify proper and safe operation.

Appendix F – 10K Electronic Transfer Switch (Continued)

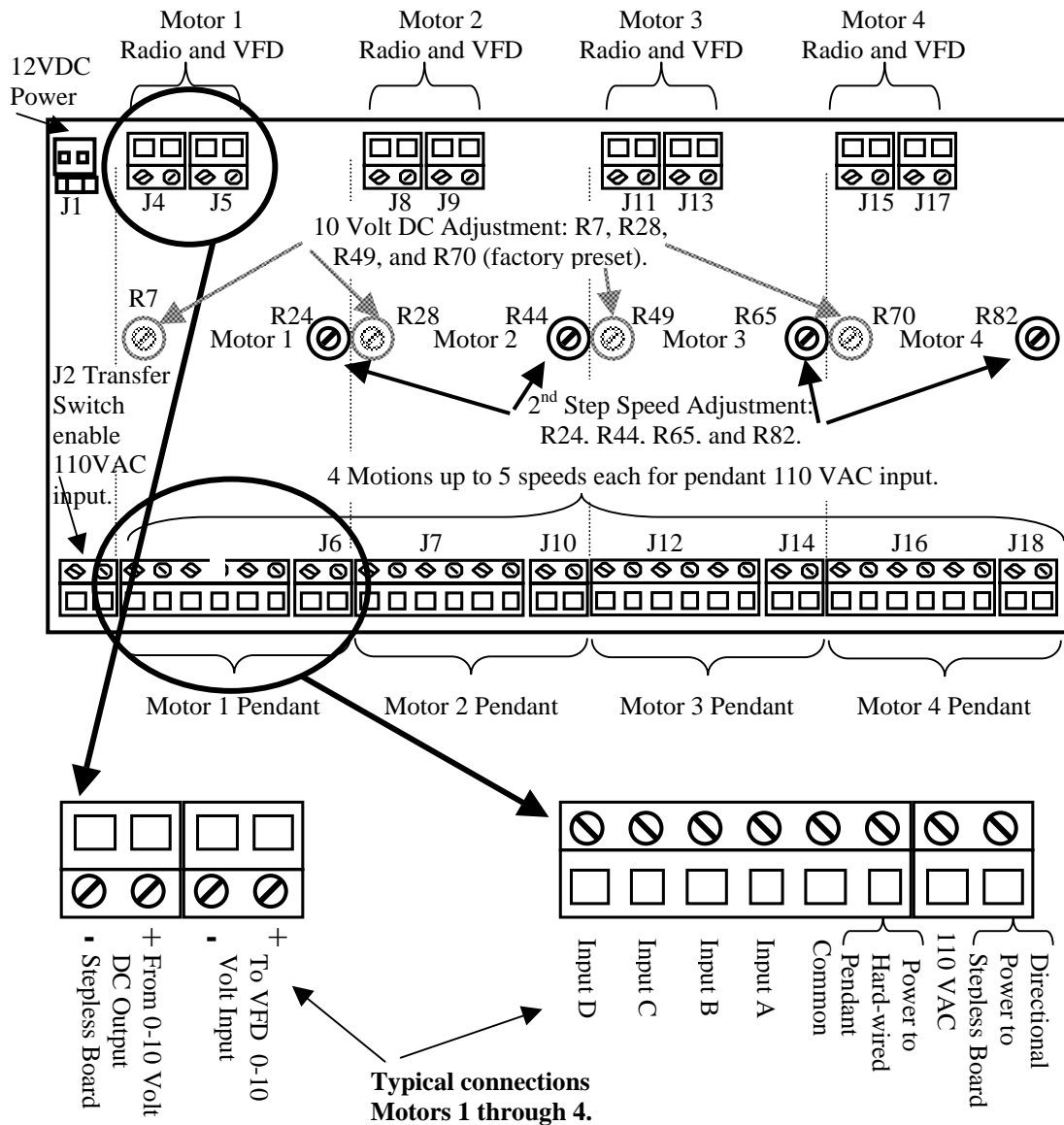

**Figure F-2. 10K Electronic Transfer Switch Board.
E10192**

Appendix F – 10K Electronic Transfer Switch (Continued)

**Table 1.a Model 10KS1207P7M2
Electronic Transfer Switch Wiring**

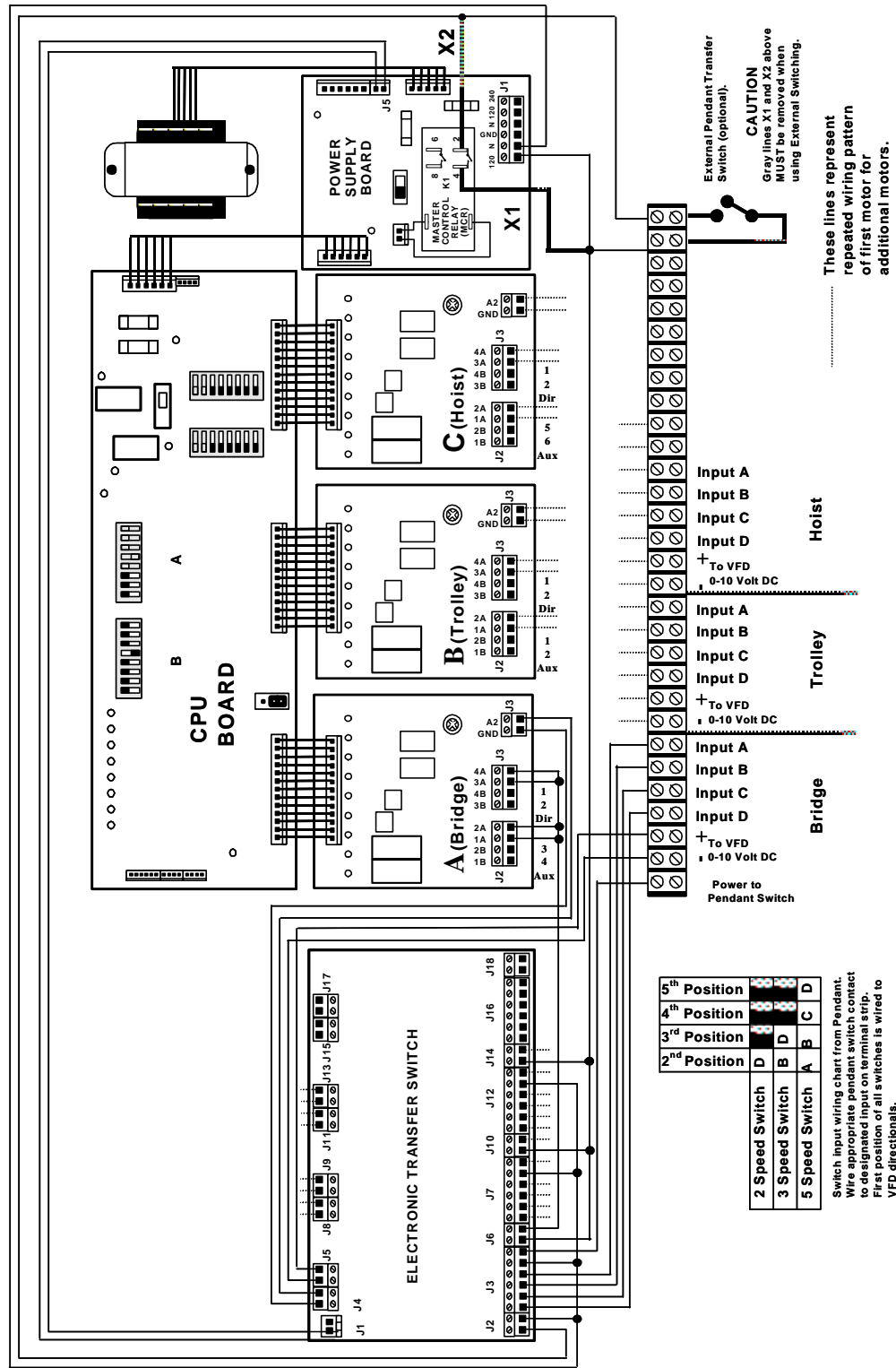

5 th Position		D
4 th Position		C
3 rd Position		B
2 nd Position		A

2 Speed Switch	D	B	A	D
3 Speed Switch	D	B	A	C
5 Speed Switch	D	B	A	C

Switch input wiring chart from Pendant. Wire appropriate pendant switch contact to designated input on terminal strip. First position of all switches is wired to VFD directionals.