

## **Table of Contents**

<b>Forward</b> .....	<b>1</b>
<b>Section 1: Introduction</b> .....	<b>2</b>
1.1 General .....	2
1.2 Receiving .....	2
<b>Section 2: Installation</b> .....	<b>3</b>
2.1 Location .....	3
2.2 Positioning .....	3
2.3 Mounting Dimensions .....	4
2.4 Specifications .....	5
<b>Section 3: Wiring</b> .....	<b>6</b>
3.1 Main AC Power Interconnections .....	6
3.1.1 Input Fuse or Circuit Breaker Selection .....	8
3.1.2 Wire Size .....	8
3.1.3 Grounding .....	8
3.1.4 Motor Thermal Overload Relay .....	9
3.1.5 Motor Brake Magnetic Contactor .....	10
3.1.6 Magnetic Mainline Contactor .....	10
3.1.7 Special Warnings for Power Semi-Conductors .....	10
3.2 Control Circuit Interconnections .....	11
3.2.1 Control Wire Size .....	12
3.2.2 Direction and Speed Selection Input Commands .....	12
3.2.3 Motor Brake Interlock Output Command .....	12
3.2.4 Interface Options and Specifications .....	13
3.2.5 Fault Relay Output Contacts .....	13
3.2.6 Additional Wiring Precautions .....	14
3.2.6.1 R-C Surge Absorber Specifications .....	14
3.2.6.2 AC Reactor Specifications .....	15

# Table of Contents

---

<b>Section 4: Quick Programming</b> .....	<b>16</b>
4.1 Quick Programming: Two-Speed Multi-Step Speed Control .....	16
4.2 Quick Programming: Three-Speed Multi-Step Speed Control .....	18
4.3 Quick Programming: Two-Step Infinitely Variable Speed Control .....	20
4.4 Quick Programming: Three-Step Infinitely Variable Speed Control .....	22
<b>Section 5: Control Flexibility</b> .....	<b>24</b>
5.1 Speed Control Method Definitions (Set by DS1-1 and DS1-2) .....	24
5.1.1 Two-Speed Multi-Step Speed Control Method (DS1-1 = Off, DS1-2 = Off) .....	24
5.1.1.1 Control Circuit Wiring Diagram (Two-Speed Multi-Step Control Mode) .....	25
5.1.1.2 Control Circuit Input Sequence (Two-Speed Multi-Step Control Mode) .....	25
5.1.2 Three-Speed Multi-Step Speed Control Method (DS1-1 = Off, DS1-2 = On) .....	26
5.1.2.1 Control Circuit Wiring Diagram (Three-Speed Multi-Step Control Mode) .....	27
5.1.2.2 Control Circuit Input Sequence (Three-Speed Multi-Step Control Mode) .....	27
5.1.3 Two-Step Infinitely Variable Speed Control DS1-1 = On, DS1-2 = Off .....	28
5.1.3.1 Control Circuit Wiring Diagram (Two-Step Infinitely Variable Speed Control) .....	30
5.1.3.2 Control Circuit Input Sequence (Two-Step Infinitely Variable Speed Control Mode) .....	30
5.1.4 Three-Step Infinitely Variable Speed Control Method DS1-1 = On, DS1-2 = On .....	31
5.1.4.1 Control Circuit Wiring Diagram (Three-Step Infinitely Variable Speed Control Mode) .....	33

5.1.4.2	Control Circuit Input Sequence (Three-Step Infinitely Variable Speed Control Mode) .....	33
5.2	Stopping Method Definitions (DS1-3 Function) .....	34
5.2.1	Immediate Stop at STOP Command .....	34
5.2.2	Decelerate at STOP Command .....	35
<b>Section 6:</b>	<b>Settings and Adjustments .....</b>	<b>36</b>
6.1	General Description of Settings and Adjustments .....	36
6.2	Location of Adjusting Devices .....	37
6.3	TM2 Settings and Adjustments .....	38
6.3.1	RDS1-Acceleration Time/RDS2-Deceleration Time Adjustments .....	38
6.3.2	RDS3-Voltage/Frequency Pattern Adjustments .....	39
6.3.3	Voltage/Frequency Pattern Selection Procedure .....	40
6.3.4	RDS1 (Accel Time), RDS2 (Decel Time), RDS3 (V/f Pattern) Settings.....	41
6.3.5	DS1-9 and DS1-10 - Analog Frequency Reference Settings .....	41
6.3.6	Special Functions of VR1, VR2 and VR3 .....	42
6.3.6.1	Special Function of VR1: Multi-Step First Speed/ Lower Limit Adjustment .....	42
6.3.6.2	Special Function of VR2: Multi-Step Second Speed Adjustment .....	43
6.3.6.3	Special Function of VR3: Multi-Step Third Speed/ Upper Limit Adjustment .....	44
<b>Section 7:</b>	<b>Checks Before Operation .....</b>	<b>45</b>
<b>Section 8:</b>	<b>Maintenance .....</b>	<b>46</b>

# *Table of Contents*

---

<b>Section 9: Troubleshooting .....</b>	<b>47</b>
9.1 Failure Indications of IMPULSE•Sjr. ....	47
9.2 Troubleshooting Flow Chart .....	48
9.3 Information Check List .....	50
9.4 Power Section Test for IMPULSE•Sjr. ....	53
9.4.1 Input Rectifier Check .....	54
9.4.2 Output Transistor Check .....	55
 <b>Appendix I: External Braking Resistors .....</b>	 <b>56</b>
 <b>Appendix II: Reactors .....</b>	 <b>57</b>
 <b>Appendix III: Recommended Wiring Practices .....</b>	 <b>58</b>

## **Thank You!**

Electromotive Systems, Inc. appreciates your purchase of this IMPULSE•Sjr. adjustable frequency drive. When properly installed, operated and maintained, the IMPULSE•Sjr. will provide a lifetime of reliable operation. It is MANDATORY that the person who operates, inspects, and maintains this equipment thoroughly read and understand this manual.

This instruction manual has been designed to serve as a self-supporting guide for the proper installation, operation, and maintenance of the IMPULSE•Sjr. adjustable frequency drive. If you require additional assistance, please feel free to contact either your local supplier or Electromotive Systems by phone at **414/783-3500** or by fax at **414/783-3510**.

## **Note:**

Throughout this instruction manual IMPULSE•Sjr. will be referred to as an adjustable frequency drive, drive or inverter. All references should be considered as one in the same.

## **Danger!**

**Do NOT touch any circuit components while AC main power is on or immediately after the main AC power is disconnected from the unit. You must first wait until the red "CHARGE" lamp on the main circuit board (TM2) is extinguished. It may take as long as 10 minutes for the charge on the main DC bus capacitors to drop to a safe level. Failure to adhere to this warning could result in serious injury.**

© 1994 ELECTROMOTIVE SYSTEMS, INC.

All rights reserved. The above notice applies to all copyrighted materials included with this product, including, but not limited to, this manual and the software embodied within the product. This manual is intended for the sole use of the person to whom it was provided, and any unauthorized distribution of the manual or dispersal of its contents is strictly forbidden. This manual may not be reproduced in whole or in part by any means whatsoever without the expressed written permission of ELECTROMOTIVE SYSTEMS, INC.

## **Section 1: Introduction**

### **1.1 General**

IMPULSE•Sjr. represents a new age in adjustable frequency motor controls using microprocessor-based digital control of all functions and settings. Modifications and adjustments are easily performed using on-board switches.

IMPULSE•Sjr. incorporates a high performance Pulse Width Modulated (PWM) design generating a variable voltage - variable frequency output that closely approximates a sinusoidal current waveform to allow variable speed control of any conventional squirrel cage, three-phase induction motor.

IMPULSE•Sjr. is a unique hardware and software configuration specifically designed for application to crane, hoist and monorail systems. This product is the direct result of years of experience in applying adjustable frequency drives to satisfy the demanding requirements of this market.

### **1.2 Receiving**

This unit has been put through demanding tests at the factory prior to shipment. Before unpacking please check the following:

- Read the specifications sticker on outside of box. Compare the description on that sticker with the description of the product on your purchase order.
- Inspect for damage sustained in transit. Damage to carton may be indicative of unit damage.

After unpacking, please check the following:

- Check to see that the specifications sticker (shipped loose) with the unit matches your application requirement (i.e. current and voltage).
- Check to see that all electrical connections and screws are secure.
- Verify that there is no visible damage to any of the components.

If any part of the IMPULSE•Sjr. is damaged or lost, immediately notify both the carrier and Electromotive Systems.

## Section 2: Installation

**Special Note:** If you purchased this IMPULSE•Sjr. as part of an Electromotive Systems pre-engineered, TCONTROLS® motor control panel, you should skip Sections 2 and 3 and proceed directly to Section 4.

### 2.1 Location

Proper location of the IMPULSE•Sjr. is imperative to achieve optimum performance and a normal operating life. These units should always be installed in areas where the following conditions exist:

- Ambient operating temperature is between +14 ~ +122° F (-10 ~ +50° C) (open chassis).
- Protected from rain and moisture.
- Protected from corrosive gases or liquids.
- Sheltered from direct sunlight.
- Free from metallic particles or excessive airborne dust.
- Free from excessive vibration (see specifications).

### 2.2 Positioning

For cooling and maintenance purposes, make sure that there is sufficient clearance around the IMPULSE•Sjr. whether it is enclosed in a cabinet or not, as shown below. To maintain effective air flow/cooling, IMPULSE•Sjr. must be installed with heatsink ribs oriented vertically.

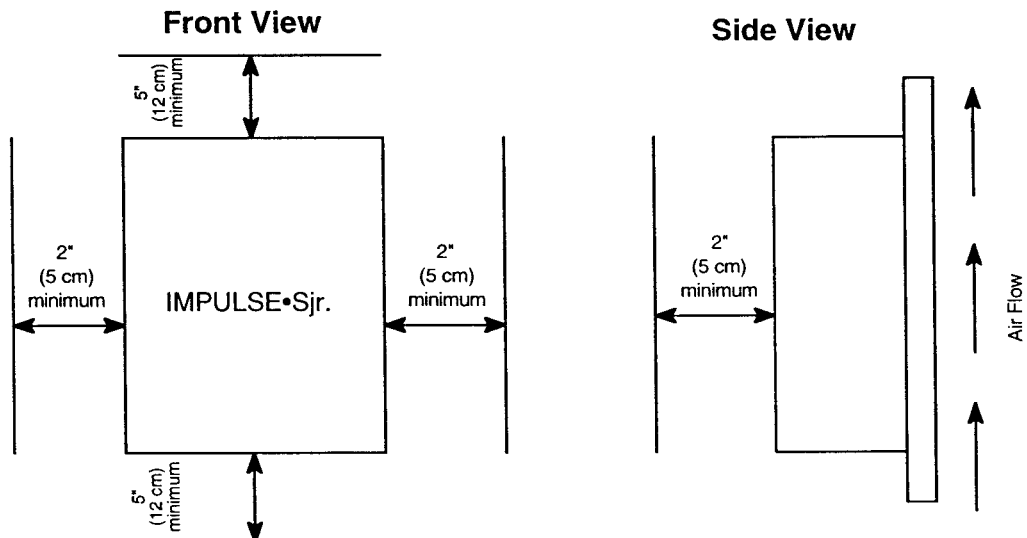

### 2.3 Mounting Dimensions (in inches)

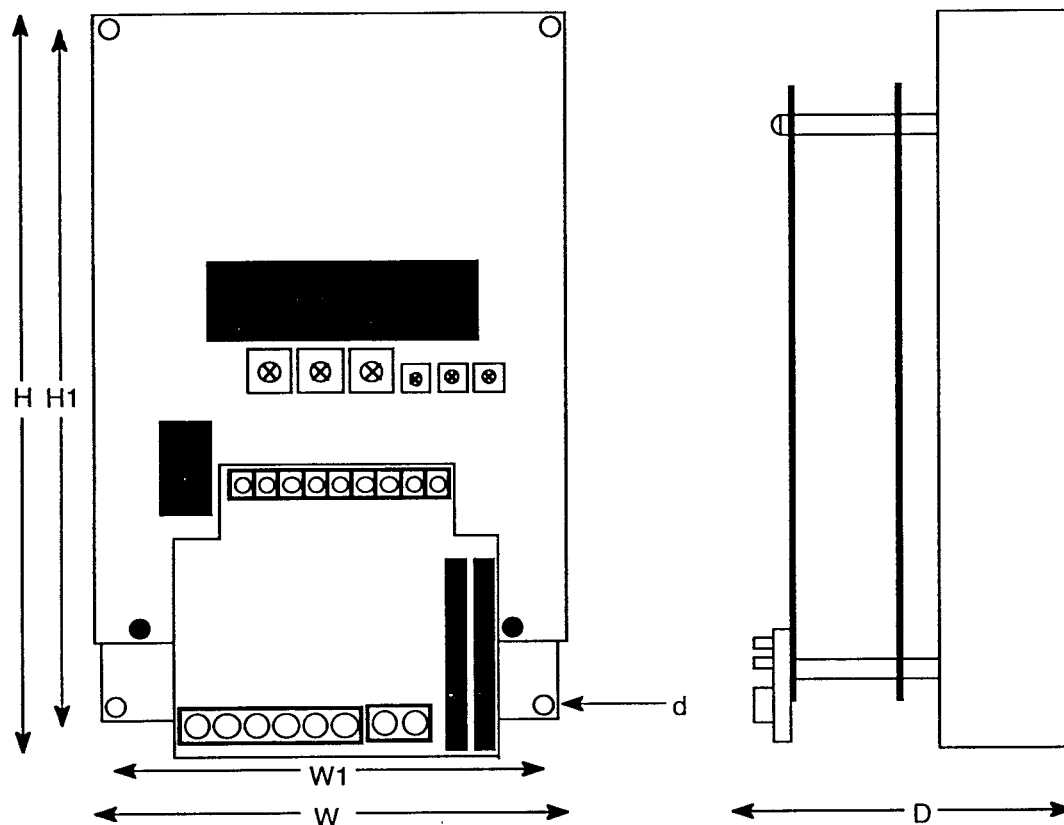

Model Number	H	H1	W	W1	D	d	Wt. in lbs. (kg.)
230AFD1-Sjr	6.89 (175)	6.42 (163)	4.53 (115)	4.13 (105)	4.71 (119)	0.19 (4.8)	2.52 (1.14)
230AFD2-Sjr	7.48 (190)	7.09 (180)	5.12 (130)	4.72 (120)			2.96 (1.34)
230AFD3-Sjr	7.87 (200)	7.32 (186)	5.51 (140)	5.04 (128)	5.74 (146)	0.22 (5.5)	6.26 (2.84)
230AFD5-Sjr	8.46 (215)	7.91 (201)	6.10 (155)	5.63 (143)	6.53 (166)		8.46 (3.84)
460AFD1-Sjr	6.89 (175)	6.42 (163)	4.72 (120)	4.25 (108)	4.95 (126)	0.19 (4.8)	4.94 (2.24)
460AFD2-Sjr	7.48 (190)	7.01 (178)			5.58 (142)		5.82 (2.64)
460AFD3-Sjr			6.92 (176)	5.82 (2.64)			
460AFD5-Sjr	9.06 (230)	8.50 (216)	5.51 (140)	4.96 (126)	6.92 (176)		12.42 (5.64)
460AFD7.5-Sjr	12.6 (320)	11.89 (302)	7.28 (185)	6.69 (170)	8.0 (203)	0.24 (6.1)	15.2 (6.90)
460AFD10-Sjr							15.4 (6.99)

Weight and dimensions do not include optional dynamic braking resistor. For more information about these dynamic braking resistors, please see Appendix I of this manual.



## 2.4 Specifications

Output Characteristics	Input Voltage 200 to 230V				Input Voltage 380 to 480V					
Model Number	230AFD (Hp) - Sjr				460AFD (Hp) - Sjr					
Horsepower* (Hp)	1	2	3	5	1	2	3	5	7.5	10
kW	0.75	1.5	2.2	3.7	0.75	1.5	2.2	3.7	5.5	7.5
Max. allowable FLA for traverse and hoisting motions	4.2	7.5	9.7	17.5	2.3	4.0	5.5	9.0	11.0	17.5
Max. allowable FLA for worm gear hoists	3.4	6.0	7.7	14.0	1.8	3.2	4.4	7.2	8.8	14.0
Max. output voltage	3-Phase 200/208/220/230V (Proportional to input voltage)				3-Phase 380/400/415/440/460V (Proportional to input voltage)					
Output frequency range	2 to 120 Hz (Maximum frequency for V/f pattern is adjustable between 60 and 120 Hz)									

\* Horsepower is based on standard NEMA B 4-pole squirrel cage motor. Size and mass of crane should always be considered when sizing drive.

Power Supply	Input Voltage 200 to 230V		Input Voltage 380 to 480V	
Model Number	230AFD (Hp) - Sjr		460AFD (Hp) - Sjr	
Rated input voltage and frequency	3-Phase 200/208/220V, 50/60 Hz		3-Phase 380/400/415/440/460V, 50/60 Hz	
Allowable voltage fluctuation	± 10%			
Allowable frequency fluctuation	± 5%			

Control Characteristics	All IMPULSE•Sjr models
Control method	Sine wave PWM
Control commands	Commanded by a 16-bit microprocessor through a fully programmable proprietary EPROM
Frequency control range	30 to 1 (frequency range that allows for a minimum 150% torque)
Frequency accuracy	± 0.5% (+14 to +104 °F, -10 to +40 °C)
Frequency setting signal	Digital (dry circuit contact closure) Analog [0 to 10 VDC (20 kΩ), 4-20mA (250Ω)]
Accel/decel time	2.5 to 20 sec (accel/decel set independently)
Braking torque	Approx. 20% (up to approx. 150% with dynamic braking resistor package)
V/f patterns	Adjustable

Protective Functions	Input Voltage 200 to 230V		Input Voltage 380 to 480V	
Model Number	230AFD (Hp) - Sjr		460AFD (Hp) - Sjr	
Instantaneous overcurrent	Inverter output is shut off at 300% rated current			
Overload	150% of horizontal motion continuous output current rating for one minute			
Overvoltage	If DC bus voltage exceeds 410V		If DC bus voltage exceeds 800V	
Undervoltage	If DC bus voltage drops to 210V or below		If DC bus voltage drops to 420V or below	
Ground fault	Provided by electronic circuit			
Power charge indication	Charge lamp stays ON until DC bus drops to 50V			

Environmental Conditions	All IMPULSE•Sjr models
Location	Indoor (protected from corrosive gases and dust)
Ambient temperature	+14 to +122 °F (-10 to +50 °C) (open chassis)
Humidity	90% RH (no condensation)
Vibration	1G less than 20 Hz, up to 0.2 G at 20 to 50 Hz

## Section 3: Wiring

**Special Note:** If you purchased this IMPULSE•Sjr. as part of an Electromotive Systems pre-engineered, *TCONTROLS* motor control panel you should skip Section 3 and proceed directly to Section 4.

Section 3 provides Electromotive Systems' recommendations regarding the power and control circuit wiring of the IMPULSE•Sjr. unit. Wiring diagrams are provided for use with a three-phase motor brake, a 230V single-phase motor brake, and a 460V single-phase motor brake. However, these are only suggestions. **You must follow the NEC and your local applicable codes whenever making any of the interconnections to this unit.**

### 3.1 Main AC Power Interconnections

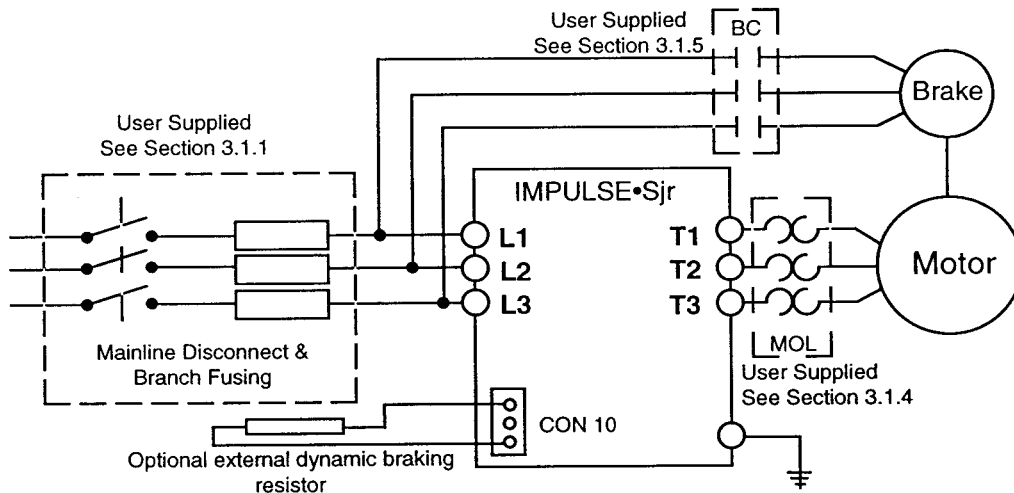

**IMPULSE•Sjr used with three-phase motor brake**

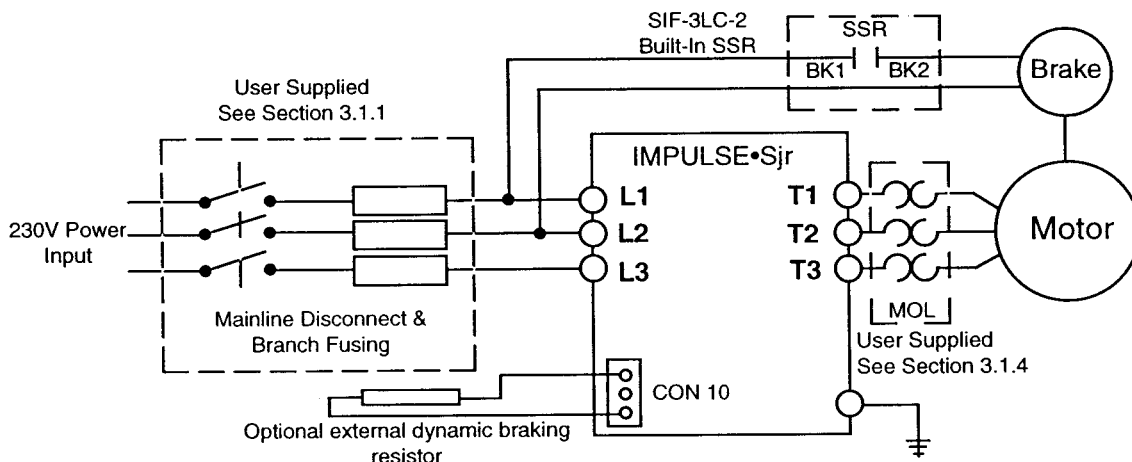

**IMPULSE•Sjr used with 230V single-phase brake coils**

### 3.1 Main AC Power Connections (continued)

For applications with the following characteristics:

- Power supply is 460V, 3Ø
- Motor is 460V, 3Ø
- Mechanical brake coil is 460V, 1Ø, ≤ 4 Amps

An optional interface card (SIF-3LC-4) is available for the IMPULSE•Sjr. The SIF-3LC-4 interface card has dual SSR devices capable of directly controlling the mechanical brake... operation without an intermediate contactor. If this interface is applied, there is no requirement for brake contactor coil snubbers because no brake contactor coil exists.

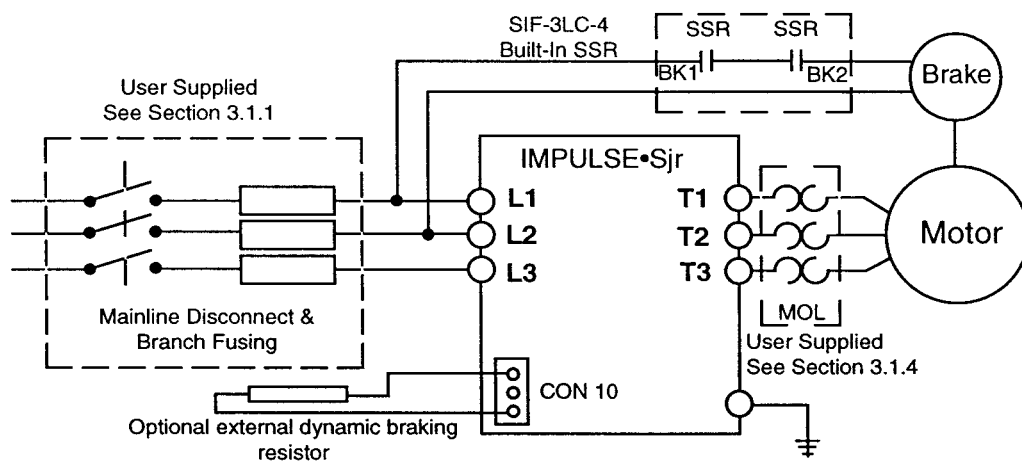

**IMPULSE•Sjr used with 460V single-phase brake coils**

### 3.1.1 Input Fuse or Circuit Breaker Selection

You should have some disconnecting means and branch circuit protection between the incoming three-phase power supply and the IMPULSE•Sjr. This branch circuit protection can either be in the form of a thermal magnetic, Molded Case Circuit Breaker (MCCB) or dual element "slow blow" type fuses. The table below provides the suggested ratings for each of the IMPULSE•Sjr. models.

Model Number	230 AFD (Hp) - Sjr				460 AFD (Hp) - Sjr					
	1	2	3	5	1	2	3	5	7.5	10
Horsepower										
Rated output current (A)	4.2	7.5	9.7	17.5	2.3	4	5.5	9	11.0	17.5
Molded case circuit breaker (MCCB) rating (A)	10	15	20	35	10	10	15	20	25	35
Input fuses (A) *	7	12	15	25	4	6	8	12	15	25

\* Use rejection type fuses, class J or class CC, with time delay. Bussman-LPJ, LPCC, Gould-ATDR, AJT, or Littelfuse-CCMR

### 3.1.2 Wire Size

The wiring used in the main power circuit should be sized according to the table below.

Model Number	230 AFD (Hp) - Sjr				460 AFD (Hp) - Sjr					
	1	2	3	5	1	2	3	5	7.5	10
Horsepower										
Rated output current (A)	4.2	7.5	9.7	17.5	2.3	4	5.5	9	11.0	17.5
Power circuit wiring (L1, L2, L3 and T1, T2, T3) minimum AWG	12 AWG	12 AWG	12 AWG	12 AWG	12 AWG	12 AWG	12 AWG	12 AWG	12 AWG	12 AWG

### 3.1.3 Grounding

Connect a positive ground using terminal E.

- Wire size should be at least 14 AWG. The lead length should be kept as short as possible.
- Ground resistance should be 100 ohm or less.
- Never ground the IMPULSE•Sjr. along with welding machines, large current machines, etc. Run the ground for the IMPULSE•Sjr. in separate conduit.

### 3.1.3 Grounding (Continued)

- Where several IMPULSE•Sjr. units are used together all of them should be directly grounded to a common ground pole. Connecting all of the IMPULSE•Sjr. earth (E) ground terminals together and running a single wire to the ground pole is also acceptable. Be careful to ensure that you do not form a loop with the ground wires.



### 3.1.4 Motor Thermal Overload Relay

To prevent the motor from overheating, a thermal overload relay (MOL) should be installed between the IMPULSE•Sjr. output terminals (T1, T2, T3) and the motor (see Section 3.1).

A thermal overload relay is not required when using motors with thermal detectors embedded in the windings of the motor. Because operating fan-cooled motors at low speeds may overheat the motor (even at rated current), the use of thermal detectors in the motor is recommended when using IMPULSE•Sjr. with fan-cooled motors. Although this is not the case with non-ventilated type motors, thermal detectors will always provide a level of protection not available with conventional thermal overload relays.

- The thermal overload relay should be adjusted to match the motor's full load amp rating.
- When multiple motors are being operated in parallel using a single IMPULSE•Sjr., a separate thermal overload relay may be provided for each motor.

A normally closed contact of the thermal overload relay should be wired in series with the (X2) signal lead to stop operation in the event of a motor thermal overload condition. (See Section 3.2.)

- When multiple thermal overload relays are being used, the relay contacts should be wired in series with the (X2) signal lead (for traverse motions).
- When motors with thermal detectors are used, the overload contact should be wired in series with the (X2) signal lead (for traverse motions).
- When only a single direction is to be interrupted by a motor overload condition, the overload relay contact should be placed in series with the appropriate directional input (such as a hoist motion).

### 3.1.5 Motor Brake Magnetic Contactor

IMPULSE•Sjr. generates a variable voltage output (dependent on output frequency). For this reason, when using a motor brake in conjunction with IMPULSE•Sjr., the brake power supply must be from the commercial supply, not derived from the IMPULSE•Sjr. output terminals.

Section 3.1 shows typical wiring schemes for both a three phase motor brake, and single phase brake coils.

- A **three phase** motor brake requires the use of a magnetic brake contactor as so detailed. We strongly recommend the use of a suitable surge absorber across the brake coil(s) to prevent excessive voltage when the coil is de-energized. For AC coil brakes you should use an R-C type (not MOV type) suppressor. For DC coil brakes you should use a diode type suppressor. See Section 3.2.6.1 for surge suppressor standards.
- When using **single phase** brake coils (120 VAC or 240 VAC or 460 VAC), note that SIF-3LC-2/4 terminals BK1 and BK2 can be wired directly to the motor brake coil. This eliminates the need for the motor brake magnetic contactor (BC). Applying the built-in solid state relay also eliminates the requirement for a surge suppressor for the brake coil.

### 3.1.6 Magnetic Mainline Contactor

**Caution:** NEVER connect a magnetic contactor between the motor and the IMPULSE•Sjr. output terminals (T1, T2, T3). Opening of such a contactor while the unit is driving a motor will result in a large transient voltage that could result in power device failure. Closing of such a contactor after the unit is running will result in a large locked rotor inrush current that could eventually weaken the power devices.

If a mainline, input magnetic contactor is used, it should be wired to provide line power to the input terminals of the IMPULSE•Sjr. (or multiple units in separate branch circuits) when the contactor coil is energized via a typical momentary/maintained on/off control circuit.

### 3.1.7 Special Warnings for Power Semi-Conductors

- Never wire the incoming AC power (230 Volt or 460 Volt) to the output terminals (T1, T2, T3). Applying this voltage to the IMPULSE•Sjr. output will destroy the unit.
- Never connect power factor correction capacitors across the output terminals (T1, T2, T3) of the unit.
- Ensure there are no short circuits on the IMPULSE•Sjr. output terminals.
- Never megger the motor leads while the IMPULSE•Sjr. is connected. The power semi-conductors are vulnerable to such high, transient voltages.

### 3.2 Control Circuit Interconnections

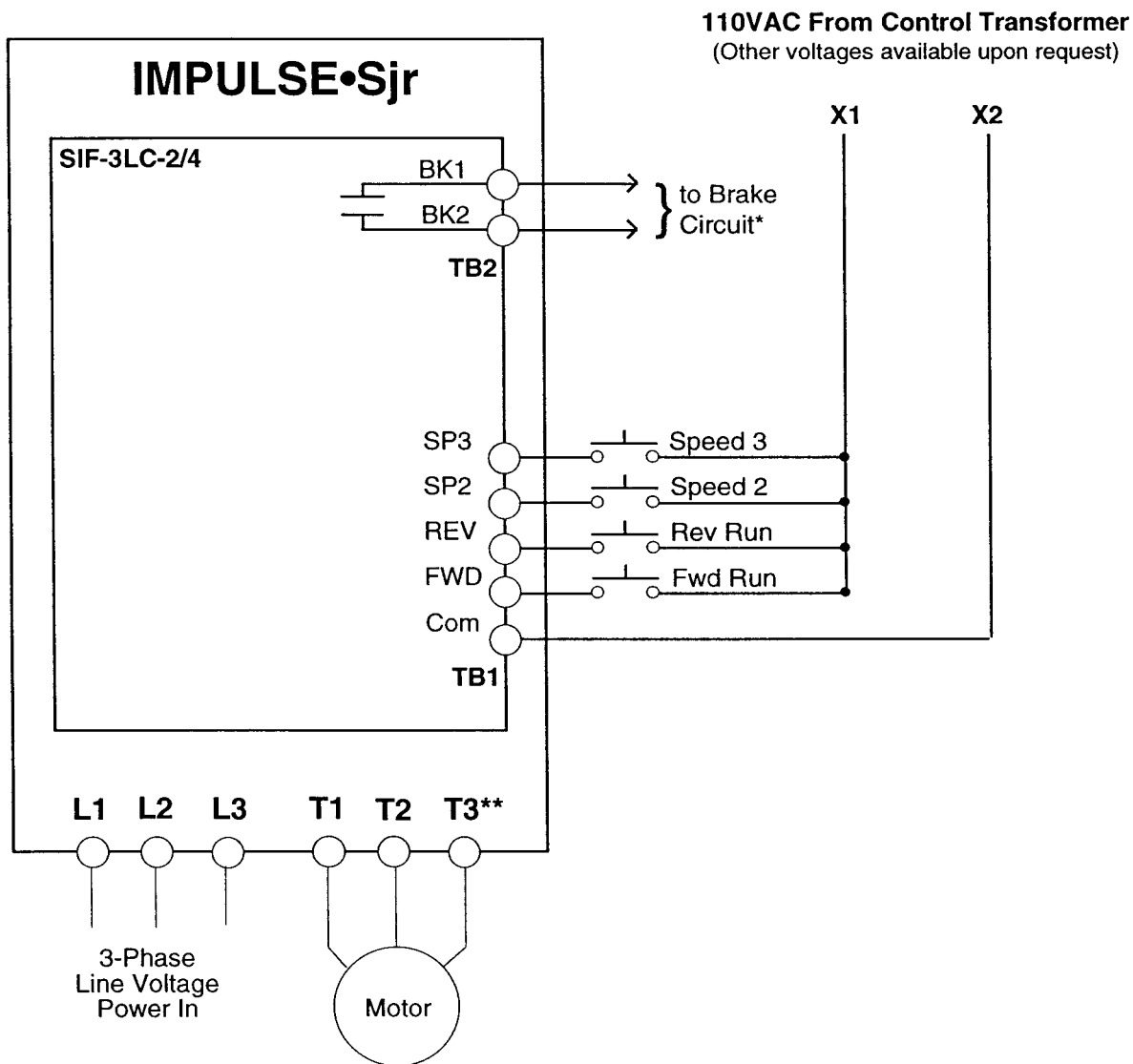

\* Brake Circuit: See sections 3.1 and 3.1.5.

\*\* Fault output terminals (1, 2, and 3 of TM2) do not connect to terminals 1, 2, and 3 of SIF-3LC-2/4. If detection of inverter fault condition is required, a direct connection to these terminals is required.

### 3.2.1 Control Wire Size

All of the control wiring used with the IMPULSE•Sjr. unit should be at least 16 AWG.

### 3.2.2 Direction and Speed Selection Input Commands

The IMPULSE•Sjr. has been specifically designed to be directly compatible with 120 VAC input signals. There is no need to add interface relays or isolation circuitry. The IMPULSE•Sjr. control inputs are all optically isolated to provide superior immunity from electrical noise common in the industrial environment.

The control inputs for crane, hoist and monorail applications are typically provided by means of a remote operator's station or pendant control (i.e. pushbutton station). Section 3.2 shows a common control scheme utilizing a cumulative-type, three-step pushbutton control.

**IMPORTANT NOTE:** The number of input steps required (one-, two-, or three-step) depends on the number of speed steps required. Section 5 of this manual outlines the various capabilities of the IMPULSE•Sjr. and lists the number of input steps required to achieve that particular method of speed control. Once the speed control method is known, the actual control circuit interconnection requirements are also known. In fact, the power and flexibility of the IMPULSE•Sjr. allows the user to change from one speed control method to another without changing any input wires, as long as each method utilizes the same number of input steps. (See Section 5 for more details.)

### 3.2.3 Motor Brake Interlock Output Command

The IMPULSE•Sjr., in combination with the SIF-3LC-2/4 interface card, has been specifically designed to provide an output signal that is used to energize the brake coil (or brake contactor coil (BC)) and release the motor brake at the same time the unit receives a forward/reverse command. This output is often referred to as a run contact output. (See Section 3.2)

**IMPORTANT NOTE:** The state of the brake interlock output signal when the IMPULSE•Sjr. receives a STOP command depends on the chosen braking method. Section 5.2 of this manual outlines the two different braking methods that are available with the IMPULSE•Sjr. Regardless of the braking method, the control wiring does not change. In fact, the power and flexibility of the IMPULSE•Sjr. allows the user to change from one braking method to another without changing any wires. (See Section 5 for more details.)



### 3.2.4 Interface Options and Specifications

Various interface cards are available for IMPULSE•Sjr. These interface options include capabilities for various input voltages and brake (SSR) output rated voltages.

Interface Card Model Number	Rated Input Voltage (AC)	Rated Input Voltage (DC)	Rated Brake SSR Output Voltage	Rated Brake SSR Output Min. Current	Rated Brake SSR Output Max. Current	Comments
SIF-3LC-2	110V	110V	20~250V	100mA	4.0A	Standard interface card for all IMPULSE•Sjr drives
SIF-3LC-4	110V	110V	380~480V	100ma	4.0A	Specified by customer
SIF-3LC-2.1	220V	220V	20~250V			
SIF-3LC-4.1			380~480V			
SIF-3LC-2.2	24V	24V	20~250V			
SIF-3LC-4.2			380~480V			
Other configurations available upon request and Electromotive Systems' Engineering approval						

### 3.2.5 Fault Relay Output Contacts

A fault relay Form C contact (normally open/normally closed) output is provided on the TM2 circuit board (terminals 1, 2 and 3). This can be used in a specific control scheme to signal an IMPULSE•Sjr. protective fault condition. (See Section 3.2.)

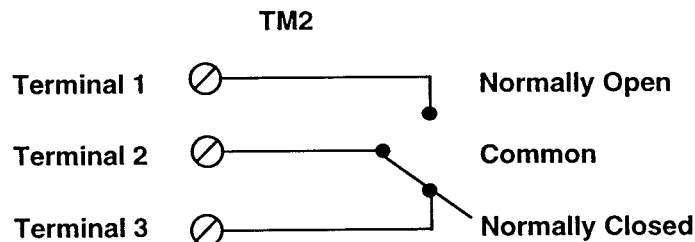

**Contact rating**  
 250 VAC, 1A, Resistive Load  
 30 VDC, 1A, Resistive Load

### 3.2.6 Additional Wiring Precautions

An R-C type (not MOV type) surge absorber must be used across the coil of all contactors and relays contained within the same electrical enclosure as the IMPULSE•Sjr. Failure to do so will result in noise related nuisance fault conditions. (See Section 3.2.6.1 for applicable surge absorbers.)

R-C type (not MOV type) surge absorbers are sometimes required to suppress the coils of AC electro-mechanical brakes. Be certain to test all functions of the IMPULSE•Sjr. system if 3Ø AC brakes are applied. (See Section 3.2.6.1 for applicable surge absorbers.) Failure to adhere to this precaution may lead to nuisance noise related fault conditions.

Source KVA MUST BE limited to  $\leq 500$  KVA to protect against premature rectifier assembly failure. If Source KVA exceeds 500 KVA, then installation of appropriate reactor is required. If multiple inverters are used, installation of individual reactors is not required. One reactor capable of combined amperage is acceptable. (See Section 3.2.6.2 for details.)

#### 3.2.6.1 R-C Surge Absorber Specifications

Applied VAC/ General Application	Capacitor	Resistor	Part Number
120 VAC (1Ø) for contactor coil/magnetic brake coils	0.47 $\mu$ F	100 $\Omega$ , 0.5W	RCS1G6
	0.47 $\mu$ F	150 $\Omega$ , 0.5W	RCS1H6
	0.47 $\mu$ F *	220 $\Omega$ , 0.5W *	RCS1A6 *
240 VAC (1Ø) for contactor coil/magnetic brake coils	0.47 $\mu$ F	100 $\Omega$ , 0.5W	RCS2G6
	0.47 $\mu$ F	150 $\Omega$ , 0.5W	RCS2H6
	0.47 $\mu$ F	220 $\Omega$ , 0.5W	RCS2A6
480 VAC (3Ø) for 3Ø brake coils	0.47 $\mu$ F	100 $\Omega$ , 7W	RCY6G-30
	0.47 $\mu$ F	220 $\Omega$ , 7W	RCY6A-30

\*Electromotive Systems standard. Part numbers are those of R-K Electronics. These parts are available from Electromotive Systems or R-K, at 513/860-4474. (If A-B brand contactor (IEC type) is used, then part number is A-B 199-FSMA1.)

### 3.2.6.2 AC Reactor Specifications

**Source KVA must be limited so as not to exceed 500KVA to protect against premature rectifier assembly failure.** If Source KVA exceeds 500, then installation of an appropriate reactor is **required**. Note that other types of similar electronic equipment are susceptible to damage by a large Source KVA as well. If multiple inverters are used, installation of individual reactors is not required. One reactor compatible with the combined amperage is acceptable.

Model Number	Max. Cont. Amps	230V Part Number	230V Max. Hp	460V Part Number	460V Max. Hp
230AFD1-Sjr	4	REA230-1	1		
230AFD2-Sjr	8	REA230-2	2		
230AFD3-Sjr	12	REA230-3	3		
230AFD5-Sjr	18	REA230-5	5		
460AFD1-Sjr	2			REA460-1	1
460AFD2-Sjr	4			REA460-2	2
460AFD3-Sjr	4			REA460-3	3
460AFD5-Sjr	8			REA460-5	5
460AFD7.5-Sjr	12			REA460-7.5	7.5
460AFD10-Sjr	18			REA460-10	10
These sizes are for combinations of multiple low capacity inverters.	25	REA230-7.5	7.5	REA460-15	15
	35	REA230-10	10	REA460-25	25
	45	REA230-15	15	REA460-30	30
	55	REA230-20	20	REA460-40	40
	80	REA230-25	25	REA460-60	60
	100	REA230-40	40	REA460-75	75
	130	REA230-50	50	REA460-100	100

Note 1: These reactors are 3% impedance type for application as input or output reactors. 3% input reactors are applied for reduction of Source KVA. If the user demands reduction of line generated noise, the use of 5% impedance reactors is suggested (please discuss these special countermeasures with Electromotive Systems Engineering personnel). See Appendix II for suggested connection details.

Note 2: 3% impedance reactors can also be used as output reactors for application utilizing wound rotor motors (with secondary circuit shorted). See Appendix II for suggested connection details.

## Section 4: Quick Programming

This section outlines the fastest way to get your IMPULSE•Sjr. up and running. This section is divided into four parts: two-speed multi-step, three-speed multi-step, two-step infinitely variable and three-step infinitely variable speed control.

### 4.1 Quick Programming: Two-Speed Multi-Step Speed Control

<p>To set IMPULSE•Sjr. for two-speed multi-step speed control, begin with DS1, which is located on the TM2 board.</p> <p>(DS1-1 through DS1-10)</p>	
---	--

#### Set your speed control method.

Sets IMPULSE•Sjr. to two-speed multi-step speed control	DS1-1 = off DS1-2 = off <i>(initial setting)</i>
---	--

*For more information, please see Section 5.1.1.*

#### Select your stopping method. Traverse or hoisting?

Do you have a traverse (horizontal) motion? Choose decelerate at STOP command	DS1-3 = off
Do you have a hoisting (vertical) motion? Choose immediate stop at STOP command	DS1-3 = on <i>(initial setting)</i>

*For more information, please see Section 5.2.*

#### Choose your first speed.

Speed	Setting
2 Hz	DS1-4 = on DS1-5 = off DS1-6 = off
3 Hz	DS1-4 = on DS1-5 = off DS1-6 = on
5 Hz	DS1-4 = on DS1-5 = on DS1-6 = off <i>(initial setting)</i>

Speed	Setting
10 Hz	DS1-4 = on DS1-5 = on DS1-6 = on
15 Hz	DS1-4 = off DS1-5 = off DS1-6 = off
20 Hz	DS1-4 = off DS1-5 = off DS1-6 = on

Speed	Setting
25 Hz	DS1-4 = off DS1-5 = on DS1-6 = off
30 Hz	DS1-4 = off DS1-5 = on DS1-6 = on

**Choose your second speed.**

Speed	Setting
45 Hz	DS1-7 = off DS1-8 = off

Speed	Setting
55 Hz	DS1-7 = on DS1-8 = off

50 Hz	DS1-7 = off DS1-8 = on
-------	---------------------------

60 Hz	DS1-7 = on DS1-8 = on
-------	--------------------------

Continue by setting RDS1 and RDS2, located on the TM2 board.



**Set your acceleration and deceleration times.**

Use RDS1 to set your acceleration time. Use RDS2 to set your deceleration time.																
Notch	0	1	2	3	4	5	6	7	8	9	A	B	C	D	E	F
Time (sec.)	2.5	3.0	3.5	4.0	4.5	5.0	5.5	6.0	6.5	7.0	8.0	9.0	10.0	12.0	15.0	20.0

*For more information, please see Sections 6.3.1 and 6.3.4.*

**Do you need any special features?**

For more information about voltage/frequency patterns, see Section 6.3.2

For other special speeds, see Section 6.3.6

Your IMPULSE•Sjr is now set up for two-speed multi-step operation.

DS1-9 and DS1-10 are used for an analog input. Their settings will not affect normal operation. For more information, see Section 6.3.5.

## 4.2 Quick Programming: Three-Speed Multi-Step Speed Control

To set IMPULSE•Sjr. for three-speed multi-step speed control, begin with DS1, which is located on the TM2 board.

(DS1-1 through DS1-10)



### Set your speed control method.

Sets IMPULSE•Sjr. to three-speed multi-step speed control	DS1-1 = off DS1-2 = on
---	---------------------------

*For more information, please see Section 5.1.2.*

### Select your stopping method. Traverse or hoisting?

Do you have a traverse (horizontal) motion? Choose decelerate at STOP command	DS1-3 = off
Do you have a hoisting (vertical) motion? Choose immediate stop at STOP command	DS1-3 = on <i>(initial setting)</i>

*For more information, please see Section 5.2.*

### Choose your first speed.

Speed	Setting
3 Hz	DS1-4 = off DS1-5 = off

Speed	Setting
10 Hz	DS1-4 = on DS1-5 = off

5 Hz	DS1-4 = off DS1-5 = on <i>(initial setting)</i>
------	---

15 Hz	DS1-4 = on DS1-5 = on
-------	--------------------------

**Choose your second speed.**

Speed	Setting
15 Hz	DS1-6 = off DS1-7 = off

Speed	Setting
30 Hz	DS1-6 = on DS1-7 = off

20 Hz	DS1-6 = off DS1-7 = on
-------	---------------------------

40 Hz	DS1-6 = on DS1-7 = on
-------	--------------------------

**Choose your third speed.**

Speed	Setting
45 Hz	DS1-8 = on

Speed	Setting
60 Hz	DS1-8 = off

Continue by setting RDS1 and RDS2, located on the TM2 board.



**Set your acceleration and deceleration times.**

Use RDS1 to set your acceleration time. Use RDS2 to set your deceleration time.																
Notch	0	1	2	3	4	5	6	7	8	9	A	B	C	D	E	F
Time (sec.)	2.5	3.0	3.5	4.0	4.5	5.0	5.5	6.0	6.5	7.0	8.0	9.0	10.0	12.0	15.0	20.0

For more information, please see Sections 6.3.1 and 6.3.4.

**Do you need any special features?**

For more information about voltage/frequency patterns, see Section 6.3.2

For other special speeds, see section 6.3.6

Your IMPULSE•Sjr is now set up for three-speed multi-step operation.

DS1-9 and DS1-10 are used for an analog input. Their settings will not affect normal operation. For more information, see Section 6.3.5.

### 4.3 Quick Programming: Two-Step Infinitely Variable Speed Control

To set IMPULSE•Sjr. for two-step infinitely variable speed control, begin with DS1, which is located on the TM2 board.

(DS1-1 through DS1-10)



#### Set your speed control method.

Sets IMPULSE•Sjr. to two-step infinitely variable speed control	DS1-1 = on DS1-2 = off
---	---------------------------

*For more information, please see Section 5.1.3.*

#### Select your stopping method. Traverse or hoisting?

Do you have a traverse (horizontal) motion? Choose decelerate at STOP command	DS1-3 = off
Do you have a hoisting (vertical) motion? Choose immediate stop at STOP command	DS1-3 = on <i>(initial setting)</i>

*For more information, please see Section 5.2.*

#### Choose your minimum speed.

Speed	Setting	Speed	Setting	Speed	Setting
2 Hz	DS1-4 = on DS1-5 = off DS1-6 = off	10 Hz	DS1-4 = on DS1-5 = on DS1-6 = on	25 Hz	DS1-4 = off DS1-5 = on DS1-6 = off
3 Hz	DS1-4 = on DS1-5 = off DS1-6 = on	15 Hz	DS1-4 = off DS1-5 = off DS1-6 = off	30 Hz	DS1-4 = off DS1-5 = on DS1-6 = on
5 Hz	DS1-4 = on DS1-5 = on DS1-6 = off <i>(initial setting)</i>	20 Hz	DS1-4 = off DS1-5 = off DS1-6 = on		



**Choose your maximum speed.**

Speed	Setting
45 Hz	DS1-7 = off DS1-8 = off

Speed	Setting
55 Hz	DS1-7 = on DS1-8 = off

50 Hz	DS1-7 = off DS1-8 = on
-------	---------------------------

60 Hz	DS1-7 = on DS1-8 = on
-------	--------------------------

Continue by setting RDS1 and RDS2, located on the TM2 board.



**Set your acceleration and deceleration times.**

Use RDS1 to set your acceleration time. Use RDS2 to set your deceleration time.																
Notch	0	1	2	3	4	5	6	7	8	9	A	B	C	D	E	F
Time (sec.)	2.5	3.0	3.5	4.0	4.5	5.0	5.5	6.0	6.5	7.0	8.0	9.0	10.0	12.0	15.0	20.0

For more information, please see Sections 6.3.1 and 6.3.4.

**Do you need any special features?**

For more information about voltage/frequency patterns, see Section 6.3.2
For other special speeds, see section 6.3.6

Your IMPULSE•Sjr is now set up for two-step infinitely variable operation.

DS1-9 and DS1-10 are used for an analog input. Their settings will not affect normal operation. For more information, see Section 6.3.5.

### 4.4 Quick Programming: Three-Step Infinitely Variable Speed Control

To set IMPULSE•Sjr. for three-step infinitely variable speed control, begin with DS1, which is located on the TM2 board.

(DS1-1 through DS1-10)



#### Set your speed control method.

Sets IMPULSE•Sjr to three-step infinitely variable speed control	DS1-1 = on DS1-2 = on
--	--------------------------

*For more information, please see Section 5.1.4.*

#### Select your stopping method. Traverse or hoisting?

Do you have a traverse (horizontal) motion? Choose decelerate at STOP command	DS1-3 = off
Do you have a hoisting (vertical) motion? Choose immediate stop at STOP command	DS1-3 = on <i>(initial setting)</i>

*For more information, please see Section 5.2.*

#### Choose your minimum speed.

Speed	Setting	Speed	Setting	Speed	Setting
2 Hz	DS1-4 = on DS1-5 = off DS1-6 = off	10 Hz	DS1-4 = on DS1-5 = on DS1-6 = on	25 Hz	DS1-4 = off DS1-5 = on DS1-6 = off
3 Hz	DS1-4 = on DS1-5 = off DS1-6 = on	15 Hz	DS1-4 = off DS1-5 = off DS1-6 = off	30 Hz	DS1-4 = off DS1-5 = on DS1-6 = on
5 Hz	DS1-4 = on DS1-5 = on DS1-6 = off <i>(initial setting)</i>	20 Hz	DS1-4 = off DS1-5 = off DS1-6 = on		

**Choose your maximum speed.**

Speed	Setting
45 Hz	DS1-7 = off DS1-8 = off

Speed	Setting
55 Hz	DS1-7 = on DS1-8 = off

50 Hz	DS1-7 = off DS1-8 = on
-------	---------------------------

60 Hz	DS1-7 = on DS1-8 = on
-------	--------------------------

Continue by setting RDS1 and RDS2, located on the TM2 board.



**Set your acceleration and deceleration times.**

Use RDS1 to set your acceleration time. Use RDS2 to set your deceleration time.

Notch	0	1	2	3	4	5	6	7	8	9	A	B	C	D	E	F
Time (sec.)	2.5	3.0	3.5	4.0	4.5	5.0	5.5	6.0	6.5	7.0	8.0	9.0	10.0	12.0	15.0	20.0

For more information, please see Sections 6.3.1 and 6.3.4.

**Do you need any special features?**

For more information about voltage/frequency patterns, see Section 6.3.2

For other special needs, see section 6.3.6

Your IMPULSE•Sjr. is now set up for three-step infinitely variable operation.

DS1-9 and DS1-10 are used for an analog input. Their settings will not affect normal operation. For more information, see Sections 6.3.5.

## Section 5: Control Flexibility

IMPULSE•Sjr. is a unique combination of hardware and software that provides the user with unparalleled sophistication and flexibility for selection of specific crane and hoist operation modes. These include:

Speed control method selection:

- Two-speed multi-step mode.
- Three-speed multi-step mode.
- Two-step infinitely variable mode.
- Three-step infinitely variable mode.

Stopping method selection:

- Immediate stop at STOP command.
- Decelerate at STOP command.

### 5.1 Speed Control Method Definitions (Set by DS1-1 and DS1-2)

#### 5.1.1 Two-Speed Multi-Step Speed Control Method (DS1-1 = Off, DS1-2 = Off)

IMPULSE•Sjr. allows the user to choose between two- and three-speed operation. The number of speeds depends on the setting of DS1-1 and DS1-2. Each input signal is assigned a frequency (speed) reference by DS1-4 ~ DS1-8 as described below:

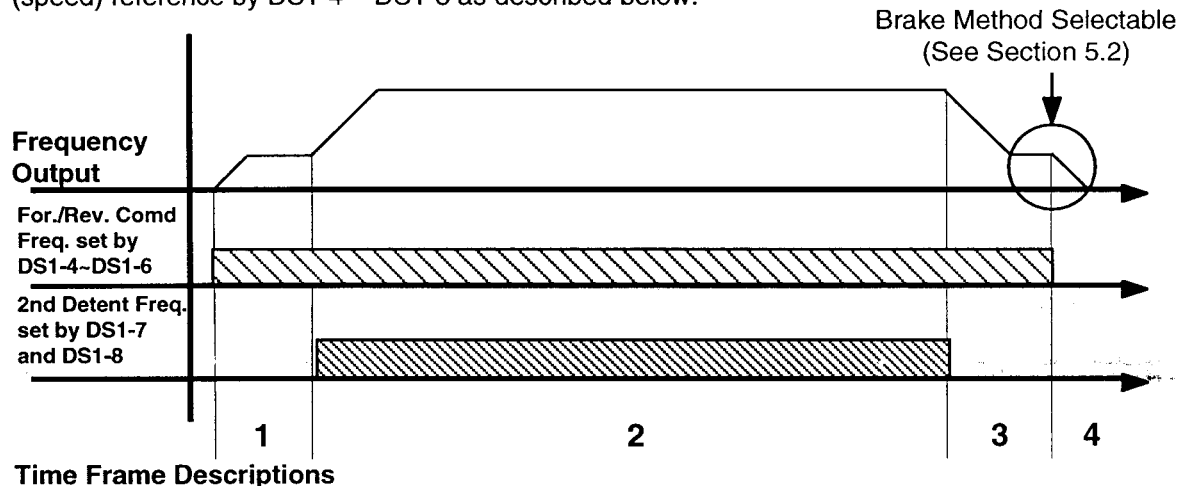

- Time Frame Descriptions**
- Time 1 Run Forward/Reverse Command.** Frequency output increases to hertz set by DS1-4, DS1-5 and DS1-6. Operation continues at this frequency.
- 2 Second Detent/Second Speed Command.** Frequency output increases to hertz set by DS1-7 and DS1-8. Operation continues at this frequency.
- 3 Removal of Second Detent/Second Speed Command.** Frequency output decreases to hertz set by DS1-4, DS1-5 and DS1-6. Operation continues at this frequency.
- 4 Absence of Commands.** Removal of RUN Forward/Reverse. STOP. Operation depends on the setting of DS1-3.

### 5.1.1.1 Control Circuit Wiring Diagram (Two-Speed Multi-Step Control Mode)

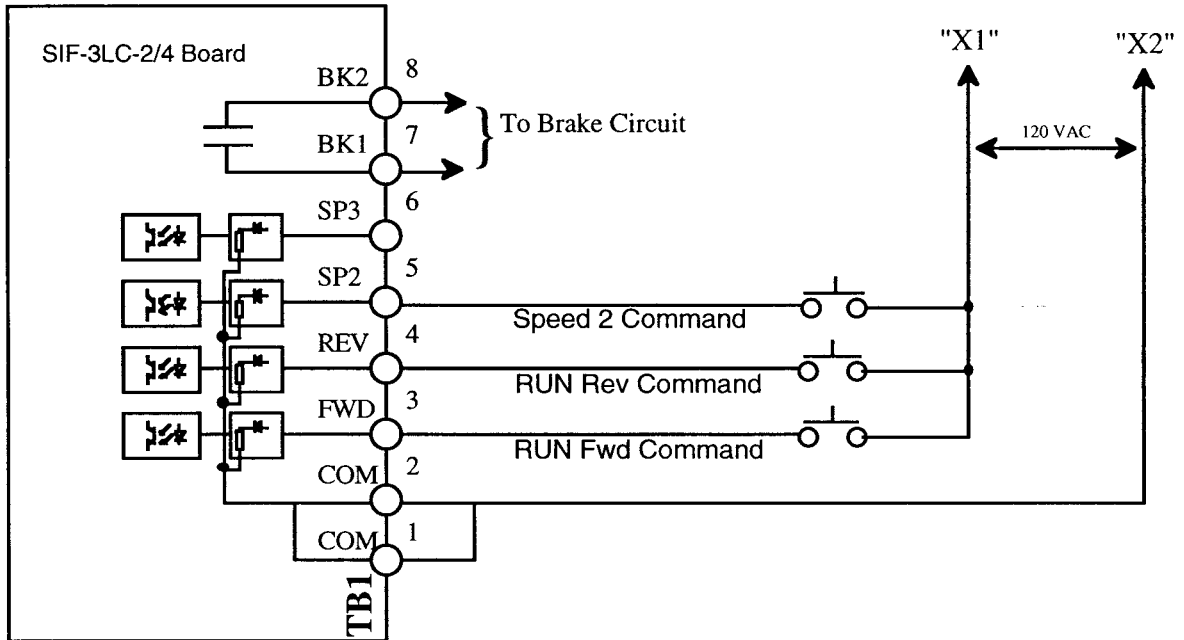

### 5.1.1.2 Control Circuit Input Sequence (Two-Speed Multi-Step Control Mode)

	Terminals COM ~ F(R)	Terminals COM ~ 2	Action
OFF	Off	-	Stops according to DS1-3 (See Section 5.2)
1st Detent RUN Fwd (Rev)	On	Off	Runs Forward (Reverse) at speed of DS1-4 ~ DS1-6
2nd Detent Speed 2	On	On	Runs Forward (Reverse) at speed of DS1-7 and DS1-8
Terminals used for two-speed control			

### 5.1.2 Three-Speed Multi-Step Speed Control Method (DS1-1 = Off, DS1-2 = On)

IMPULSE•Sjr. allows the user to choose between two- and three-speed operation. The number of speeds depends on the setting of DS1-1 and DS1-2. Each input signal is assigned a frequency (speed) reference by DS1-4 ~ DS1-8 as described below:

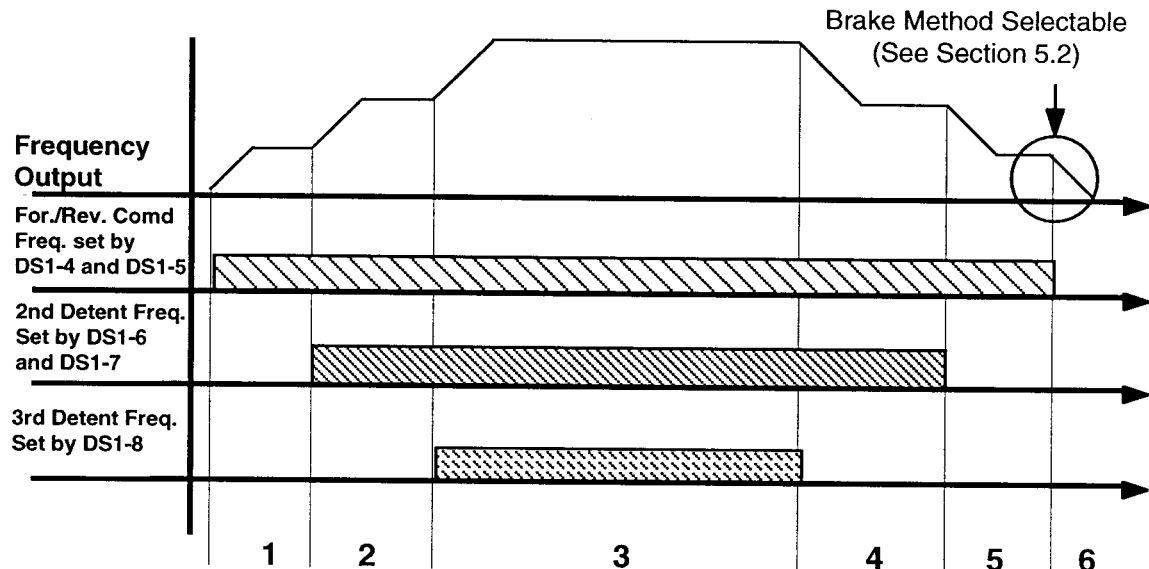

#### Time Frame Descriptions

- Time 1 Run Forward/Reverse Command.** Frequency output increases to hertz set by DS1-4 and DS1-5. Operation continues at this frequency.
- 2 Second Detent/Second Speed Command.** Frequency output increases to hertz set by DS1-6 and DS1-7. Operation continues at this frequency.
- 3 Third Detent/Third Speed Command.** Frequency output increases to hertz set by DS1-8. Operation continues at this frequency.
- 4 Removal of Third Detent/Third Speed Command.** Frequency output decreases to hertz set by DS1-6 and DS1-7. Operation continues at this frequency.
- 5 Removal of Second Detent/Second Speed Command.** Frequency output decreases to hertz set by DS1-4 and DS1-5. Operation continues at this frequency.
- 6 Absence of Commands.** Removal of RUN Forward/Reverse. STOP. Operation depends on the setting of DS1-3.

### 5.1.2.1 Control Circuit Wiring Diagram (Three-Speed Multi-Step Control Mode)

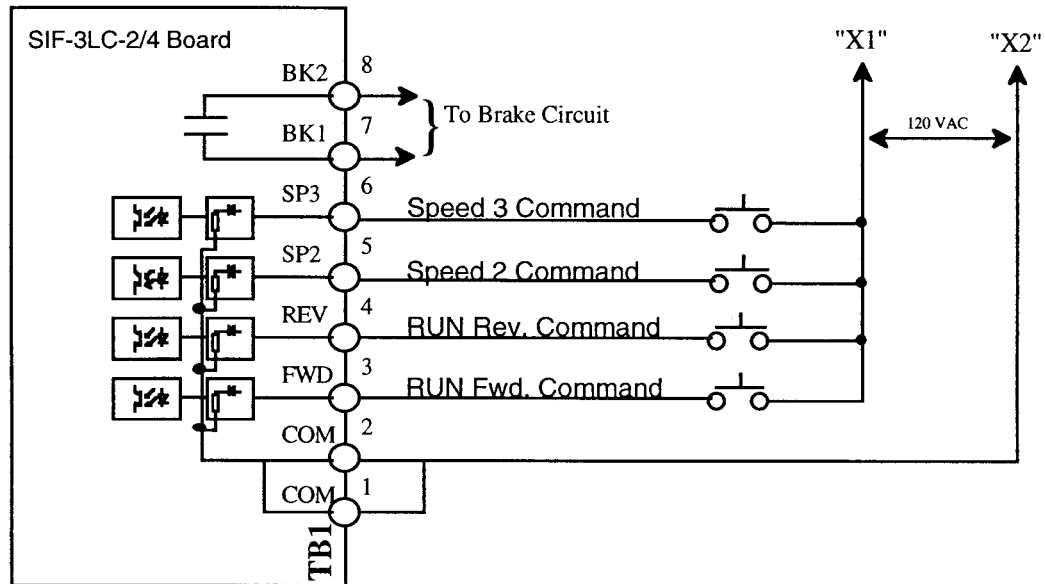

### 5.1.2.2 Control Circuit Input Sequence (Three-Speed Multi-Step Control Mode)

	Terminals COM - F(R)	Terminals COM - 2	Terminals COM - 3	Action
OFF	Off	-	-	Stops according to DS1-3 (See Section 5.2)
1st Detent RUN Fwd (Rev)	On	Off	Off	Runs Forward (Reverse) at speed of DS1-4 and DS1-5
2nd Detent Speed 2	On	On	Off	Runs Forward (Reverse) at speed of DS1-6 and DS1-7
3rd Detent Speed 3	On	On	On	Runs Forward (Reverse) at speed of DS1-8
Terminals used for three-step control				

### 5.1.3 Two-Step Infinitely Variable Speed Control DS1-1 = On, DS1-2 = Off

IMPULSE•Sjr. provides for true infinitely variable speed control with just two simple 120 VAC inputs. This unique software function allows the use of inexpensive two-speed pushbuttons. Two-step infinitely variable is most often used on horizontal (traverse) motions where it is acceptable to decelerate the motor when a STOP command is applied. (The control device is returned to the off position.) Two-step infinitely variable speed control is described by the following timing chart:

Stopping method shown is decelerate at STOP command.  
No deceleration occurs if method is immediate stop at STOP command (See Section 5.2.)

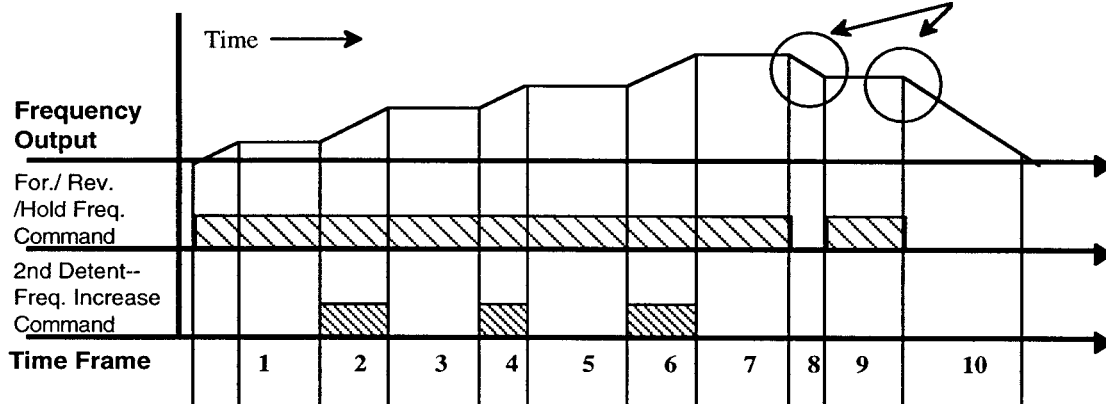

#### Time Frame Descriptions

- Time 1 Run Forward/Reverse Command.** Frequency output increases to hertz set by DS1-4 ~ DS1-6. Operation continues at this frequency.
- 2 Second Detent/Frequency Increase Command.** Frequency output increases. The longer this contact is closed, the higher the frequency output becomes. Limited only by the adjustable maximum speed (DS1-7 and DS1-8 or VR3).
- 3 First Detent/Frequency Hold Command.** Frequency output remains constant.
- 4 Second Detent/Frequency Increase Command.** Frequency output increases. The longer this contact is closed, the higher the frequency output becomes. Limited only by the adjustable upper limit (the higher of DS1-7 and DS1-8 or VR3).
- 5 First Detent/Frequency Hold Command.** Frequency output remains constant.



### 5.1.3 Two-Step Infinitely Variable Speed Control DS1-1 = On, DS1-2 = Off (Continued)

- 6 **Second Detent/Frequency Increase Command.** Frequency output increases. The longer this contact is closed, the higher the frequency output becomes. Limited only by the adjustable upper limit (the higher of DS1-7 and DS1-8 or VR3).
- 7 **First Detent/Frequency Hold Command.** Frequency output remains constant.
- 8 **Absence of Commands = STOP Command.** Output frequency decreases. The longer this input signal condition exists, the lower the output frequency becomes. Output frequency will go to zero, and the brake will set. Braking method shown is decelerate at STOP command only! (DS1-3 = Off).
- 9 **First Detent/Frequency Hold Command.** Frequency output remains constant.
- 10 **Absence of Commands = STOP Command.** Output frequency decreases. The longer this input signal condition exists, the lower the output frequency becomes. Output frequency will go to zero, and the brake will set automatically. (STOP by DS1-3 = Off).

**5.1.3.1 Control Circuit Wiring Diagram  
(Two-Step Infinitely Variable Speed Control)**

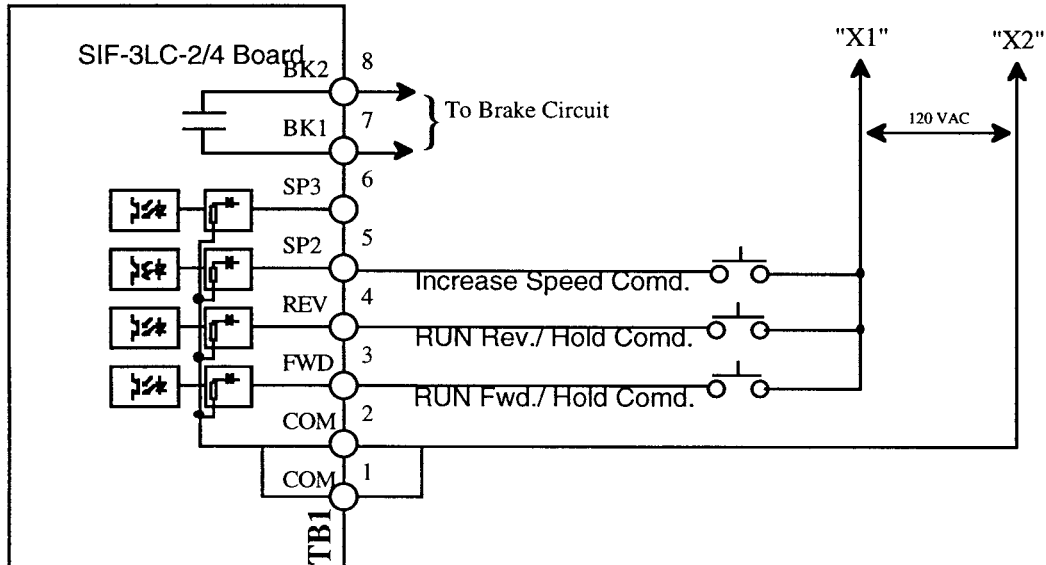

**5.1.3.2 Control Circuit Input Sequence  
(Two-Step Infinitely Variable Speed Control Mode)**

	Terminals COM ~ F(R)	Terminals COM ~ 2	Action
OFF	off	-	Stops according to DS1-3 (See Section 5.2)
1st Detent RUN Fwd (Rev)	On	off	Runs Forward (Reverse) at HIGHER of Speed of DS1-4, DS1-5 and DS1-6 or VR1/or Speed is Steady
2nd Detent Increase Speed	On	On	Speed increases to Upper Limit: set by DS1-7 and DS1-8 or VR3
Terminals used for two-step control			

### 5.1.4 Three-Step Infinitely Variable Speed Control Method DS1-1 = On, DS1-2 = On

IMPULSE•Sjr. provides true infinitely variable speed control with three simple 120 VAC inputs. Three-step infinitely variable speed control is most often used on hoist motions where it is not acceptable to decelerate the motor when a STOP command is applied. (The control device is returned to the off position.) Three-step infinitely variable speed control is described below.

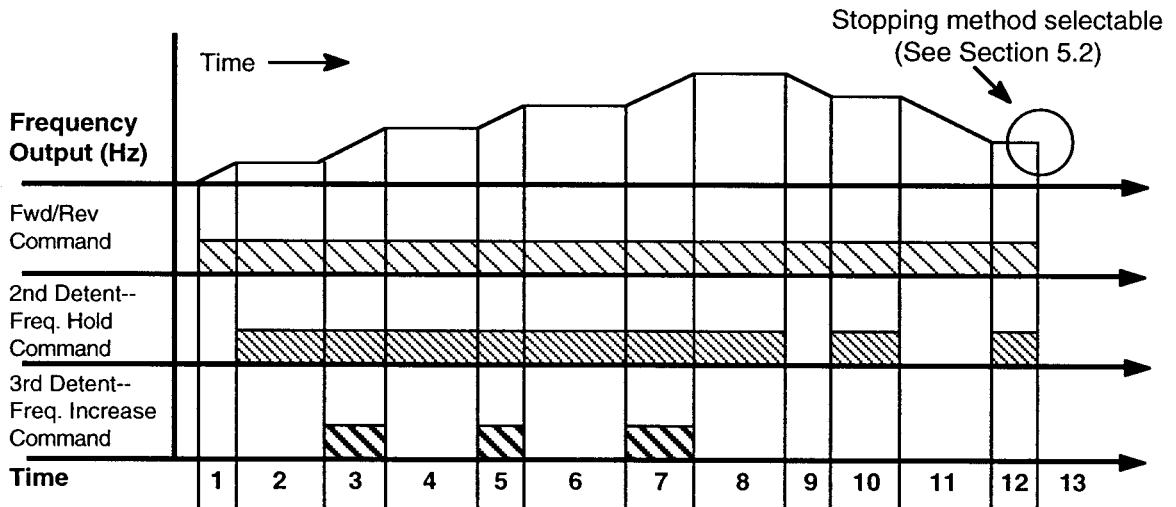

#### Time Frame Descriptions

- Time 1** **Run Forward/Reverse Command.** Frequency output increases to hertz set by DS1-4 ~ DS1-6. Operation continues at this frequency.
- 2** **Second Detent/Frequency Hold Command.** Frequency output remains constant.
- 3** **Third Detent/Frequency Increase Command.** Frequency output increases. The longer this contact is closed, the higher the output frequency becomes. Limited only by the adjustable maximum speed (DS1-7 and DS1-8 or VR3).
- 4** **Second Detent/Frequency Hold Command.** Frequency output remains constant.
- 5** **Third Detent/Frequency Increase Command.** Frequency output increases. The longer this contact is closed, the higher the output frequency becomes. Limited only by the adjustable maximum speed (DS1-7 and DS1-8 or VR3).
- 6** **Second Detent/Frequency Hold Command.** Frequency output remains constant.
- 7** **Third Detent/Frequency Increase Command.** Frequency output increases. The longer this contact is closed, the higher the output frequency becomes. Limited only by the adjustable maximum speed (DS1-7 and DS1-8 or VR3).

### **5.1.4 Three-Step Infinitely Variable Speed Control Method DS1-1 = On, DS1-2 = On (Continued)**

- 8 Second Detent/Frequency Hold Command.** Frequency output remains constant.
- 9 Run Forward/Reverse at Lower Limit Command.** Frequency output decreases. The longer this input signal condition exists, the lower the output frequency becomes. Limited only by DS1-4 ~ DS1-6.
- 10 Second Detent/Frequency Hold Command.** Frequency output remains constant.
- 11 Run Forward/Reverse Command.** Frequency output decreases. The longer this input signal condition exists, the lower the output frequency becomes. Limited only by DS1-4 ~ DS1-6.
- 12 Second Detent/Frequency Hold Command.** Frequency output remains constant.
- 13 Absence of Commands = STOP Command.** Stopping method is selectable. (See Section 5.2).

**5.1.4.1 Control Circuit Wiring Diagram  
(Three-Step Infinitely Variable Speed Control Mode)**

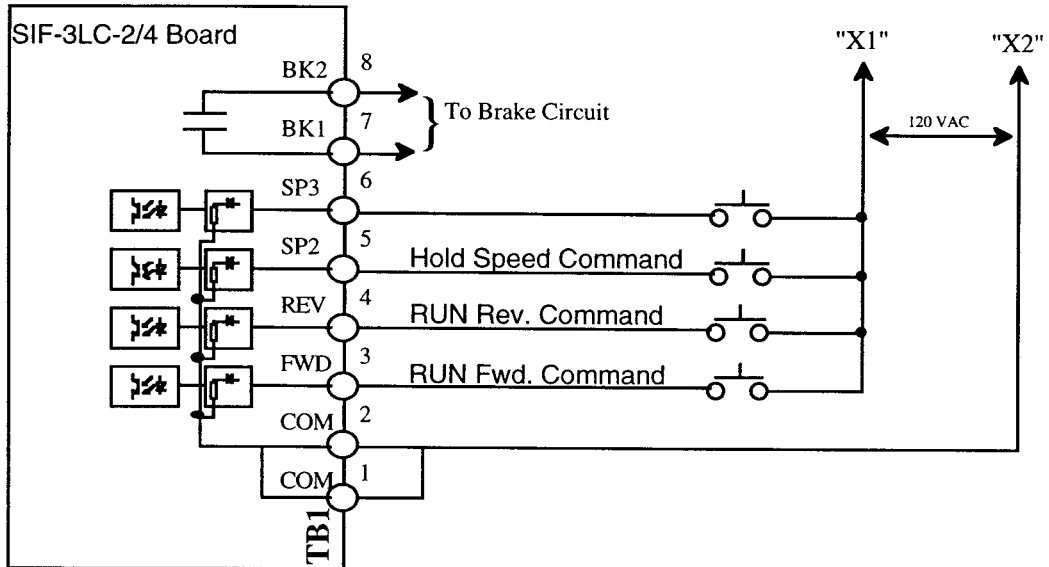

**5.1.4.2 Control Circuit Input Sequence  
(Three-Step Infinitely Variable Speed Control Mode)**

	Terminals COM ~ F(R)	Terminals COM ~ 2	Terminals COM ~ 3	Action
OFF	Off	-	-	Stops according to DS1-3 (See Section 5.2).
1st Detent RUN Fwd (Rev)	On	Off	Off	Runs Forward (Reverse) at HIGHER of Speed of DS1-4, DS1-5 and DS1-6 or VR1
2nd Detent Frequency Hold	On	On	Off	Frequency Hold Command. Frequency is Steady
3rd Detent Increase Freq.	On	On	On	Increase Frequency Command. Increases to Frequency Upper Limit set by HIGHER of DS1-7 and DS1-8 or VR3
Terminals used for three-step control				

## 5.2 Stopping Method Definitions (DS1-3 Function)

IMPULSE•Sjr. provides for both types of commonly accepted braking methods.

- Immediate stop at STOP command (DS1-3 = On).
- Decelerate at STOP command (DS1-3 = Off).

Initial stopping method is **immediate stop**. Extreme caution should be used when changing to deceleration at STOP command. Operation should not begin until the user has reviewed the deceleration time set by rotary switch RDS2. A long deceleration time will cause driven equipment to require a greater stopping distance.

### 5.2.1 Immediate Stop at STOP Command

Upon STOP command, IMPULSE•Sjr. base blocks main output transistors (i.e. the motor is electrically disconnected from the drive). The brake interlock solid state relay (terminals BK1 and BK2) sets the motor brake. See below for operation characteristics.

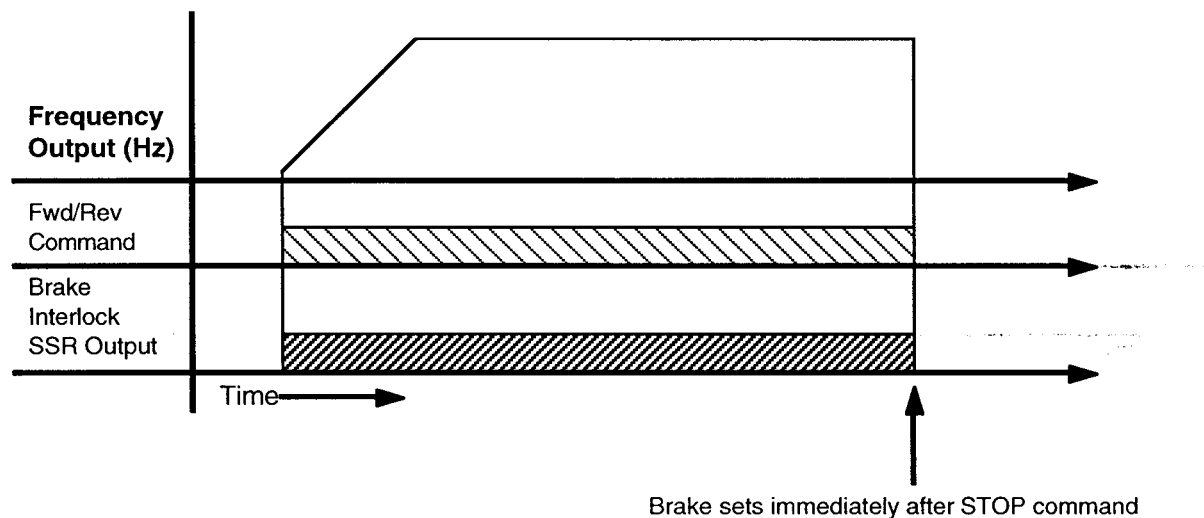

### 5.2.2 Decelerate at STOP Command

Upon STOP command, IMPULSE•Sjr. output frequency decreases to near zero, DC injects for a few milliseconds, then the brake interlock relay (terminals BK1 and BK2) sets the motor brake. (See below for operation characteristics.)

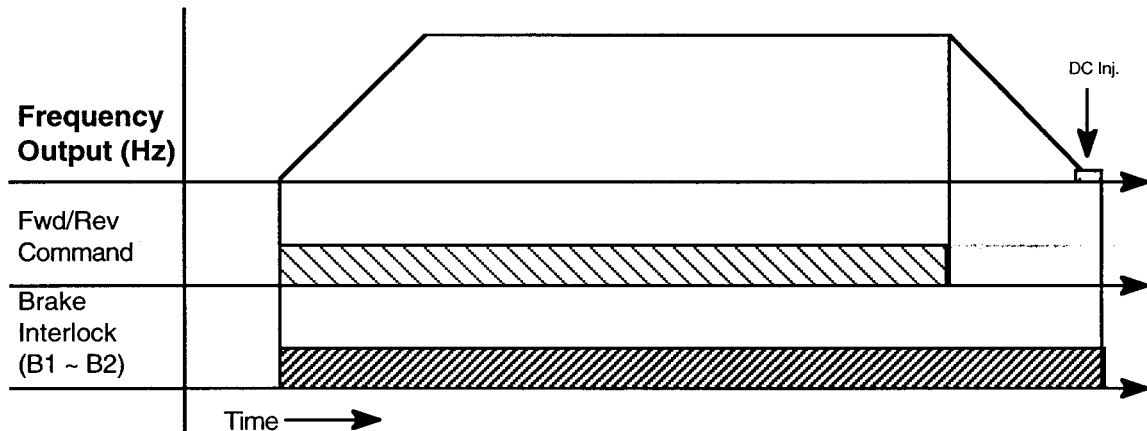

## **Section 6: - Settings and Adjustments**

Special Note: If you purchased this IMPULSE•Sjr. as part of an Electromotive Systems pre-engineered, *TCONTROLS* motor control panel, actual settings will be those specified by the order and may be different than those listed as initial settings.

### **6.1 General Description of Settings and Adjustments**

IMPULSE•Sjr. offers many specific adjustments and setting capabilities. These adjustments are accessed on both the interface card (SIF-3LC-2/4) and the logic card (TM2) of the IMPULSE•Sjr.

#### **TM2 Adjustments and Settings**

- RDS1 function:  
*acceleration time*
  
- RDS2 function:  
*deceleration time*
  
- RDS3 function:  
*voltage/frequency output pattern selection*
  
- DS1 functions:  
*speed control method selection/braking method selection/speed selections*
  
- VR1, VR2, VR3 functions:  
*special functions*



### 6.2 Location of Adjusting Devices

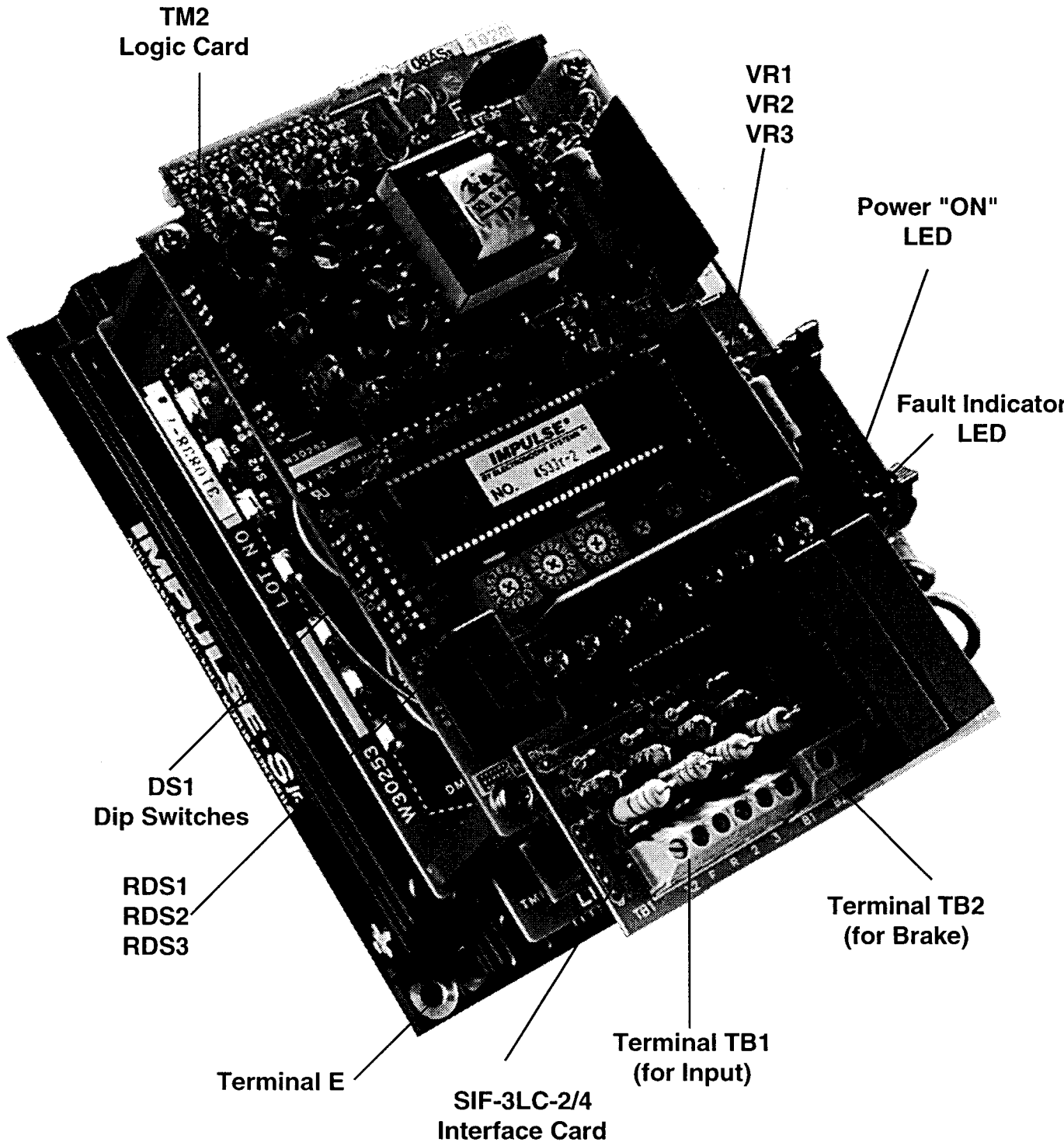

### 6.3 TM2 Settings and Adjustments

#### 6.3.1 RDS1-Acceleration Time/RDS2-Deceleration Time Adjustments

The acceleration time and the deceleration time can be independently set by rotary selector switches RDS1 and RDS2 (shown below) located on the TM2 circuit card. IMPULSE•Sjr. allows the user to select a specific accel/decel time from one of sixteen preset independent ramps (see table below.)

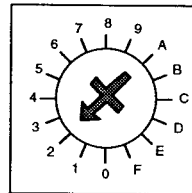
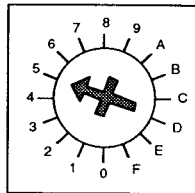

RDS1 - Acceleration Time

RDS2 - Deceleration Time

(Both are shown in the initial setting position)

RDS1/ RDS2 Notch	0	1	2	3	4	5	6	7	8	9	A	B	C	D	E	F
Accel/ Decel Time (seconds)	2.50	3.00	3.50	4.00	4.50	5.00	5.50	6.00	6.50	7.00	8.00	9.00	10.0	12.0	15.0	20.0
DC Inj. Time	0.20	0.20	0.20	0.20	0.20	0.20	0.25	0.25	0.30	0.30	0.40	0.50	0.50	0.75	1.00	1.00

The time indicated by each notch setting in the table above is the time to accelerate (decelerate) from zero frequency to maximum frequency (f-max). To determine acceleration to any intermediate frequency, follow the example below.

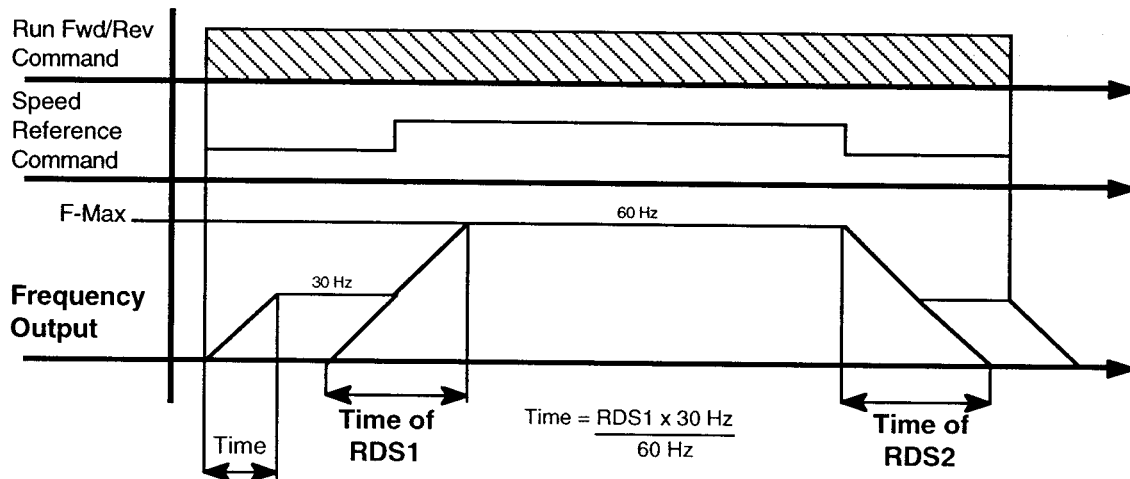

### 6.3.2 RDS3-Voltage/Frequency Pattern Adjustments

IMPULSE•Sjr. offers sixteen V/f patterns specially tailored for crane and hoist applications. Rotary selector switch RDS3 determines which pattern is applied. RDS3 serves to adjust low speed "torque boost".

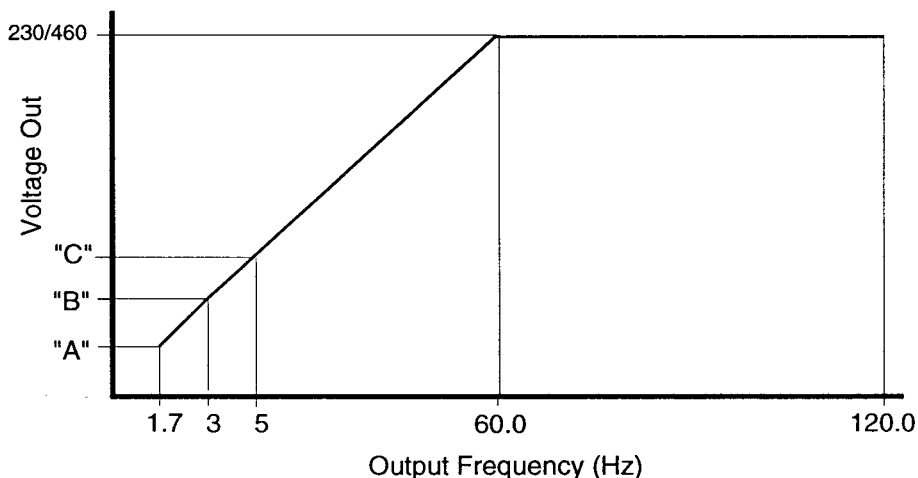
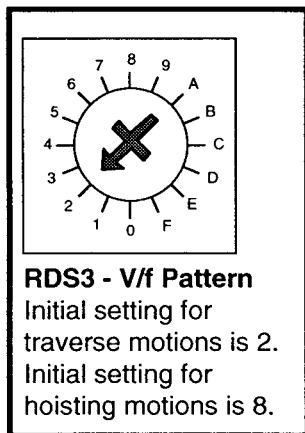

230 Volts																
RDS3 Notch	0	1	2	3	4	5	6	7	8	9	A	B	C	D	E	F
"A" Volts	9.5	11.0	11.5	13.5	14.5	16.0	17.0	13.5	15.0	16.0	17.5	18.5	20.0	21.0	22.0	22.0
"B" Volts	13.5	15.0	16.0	18.0	19.0	19.5	21.0	18.0	20.0	22.0	23.5	26.0	28.0	29.5	33.0	33.0
"C" Volts	22.0	23.5	24.5	26.5	28.0	29.0	31.0	27.5	31.0	35.0	37.5	42.5	46.0	48.5	53.5	53.5

460 Volts																
RDS3 Notch	0	1	2	3	4	5	6	7	8	9	A	B	C	D	E	F
"A" Volts	25.0	27.5	29.5	33.5	36.0	38	41.5	34.0	36.5	39.0	41.5	44.0	46.5	49.0	51.5	51.5
"B" Volts	34.0	37.0	38.5	42.0	45.0	47.0	50.0	43.0	47.5	51.0	54.5	59.5	63.5	67.0	72.0	72.0
"C" Volts	51.0	54.0	56.0	59.0	62.0	64.0	67.5	61.0	68.5	76.5	81.5	91.5	99.0	104.5	114.0	114.0

Note: Actual output voltage depends on actual input voltage. Actual output voltage may be calculated as percentage of above numbers. All relationships will be linear.

## 6.3.3 Voltage/Frequency Pattern Selection Procedure

Application notes for choosing optimum V/f pattern:

- As a general rule, notch 2 is considered the horizontal V/f pattern.
- As a general rule, notches 5 to 8 are considered hoisting V/f patterns.
- As a general rule, notches 9 to F are for extremely high torque applications (not for general use).

Procedure:

- 1) Set lowest notch appropriate for your application (horizontal or hoisting).
- 2) Run motor under "worst-case" condition (fully loaded hoist, etc.)
  - If 125% load test is required, then load for this condition.
- 3) If operation is successful, then setting is acceptable.
- 4) If operation is not successful, then try again at next higher notch value.

Continue this procedure until operation is successful.

### 6.3.4 RDS1 (Accel Time), RDS2 (Decel Time), RDS3 (V/f Pattern) Settings

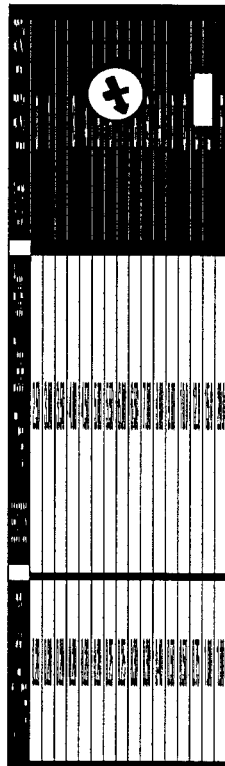

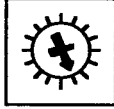
RDS2		
		
Notch	Deceleration Time (Sec)	DC Injection Time (Sec)
0	2.5	0.20
1	3.0	0.20
2	3.5	0.20
3	4.0	0.20
4	4.5	0.20
5	5.0	0.20
6	5.5	0.25
7	6.0	0.25
8	6.5	0.30
9	7.0	0.30
A	8.0	0.40
B	9.0	0.50
C	10.0	0.50
D	12.0	0.75
E	15.0	1.00
F	20.0	1.00

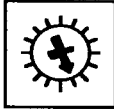
RDS3	
	
Notch	Starting Torque
0	Lowest
1	
2	Horizontal
3	
4	
5	
6	
7	
8	Hoisting
9	
A	
B	
C	
D	
E	
F	Highest

### 6.3.5 DS1-9 and DS1-10 - Analog Frequency Reference Settings

IMPULSE•Sjr. offers additional analog frequency reference selections for specific control voltage inputs other than 120V. Settings are shown below.

Frequency Reference	Setting
Set by frequency setting potentiometer or 0 - 10 VDC signal	DS1-9 = Off DS1-10 = Off
Set by 1 ~ 5 VDC signal	DS1-9 = Off DS1-10 = On
Set by 4 ~ 20 mA signal	DS1-9 = On DS1-10 = Off
Analog frequency setting is not used	DS1-9 = On DS1-10 = On

### 6.3.6 Special Functions of VR1, VR2 and VR3

VR1, VR2 and VR3 are small potentiometers mounted on the main control card (TM2). Each of the potentiometers offers a unique function and adjusts special features exclusive to IMPULSE Adjustable Frequency Motor Controls for the crane and hoist industry.

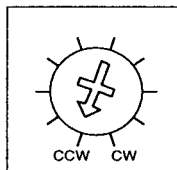

**VR1**  
Multi-Step First Speed/  
Lower Limit  
Adjustment

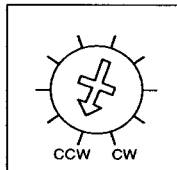

**VR2**  
Multi-Step Second  
Speed Adjustment

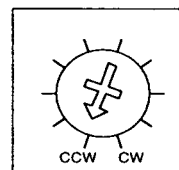

**VR3**  
Multi-Step Third Speed/  
Upper Limit  
Adjustment

CW = clockwise; CCW = counterclockwise

#### 6.3.6.1 Special Function of VR1: Multi-Step First Speed/Lower Limit Adjustment

Certain applications require output frequencies that are unavailable from the menu of digital selections. Note that VR1 has a function in both infinitely variable and multi-step speed control modes. For example, the application requires 12 Hz as the first speed (multi-step mode) or the lower limit (infinitely variable mode). Note that 12 Hz is not available via digital selection by means of the appropriate DS1 switches. Under these circumstances, the VR1 potentiometer can be used to attain the desired speed. The adjustment range of VR1 is as below:

**VR1 Function  
Infinitely Variable  
Mode**

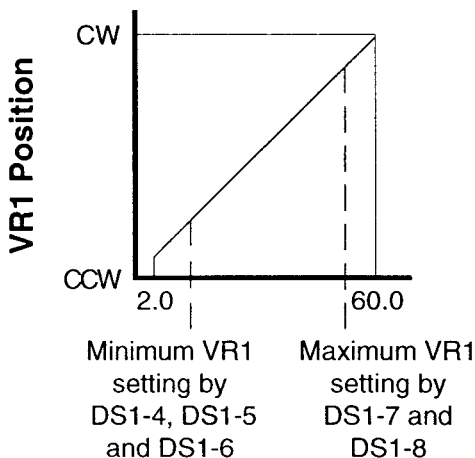

**VR1 Function  
Multi-Step Speed  
Mode**

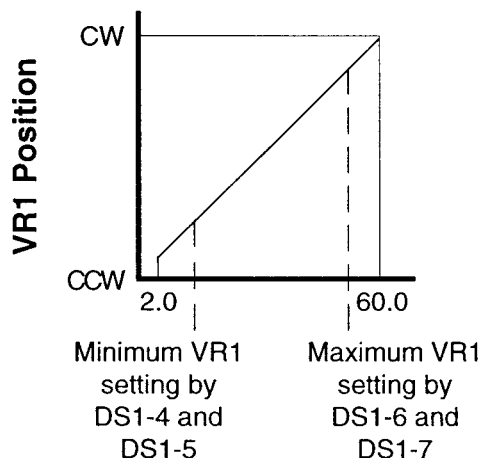

### 6.3.6.2 Special Function of VR2: Multi-Step Second Speed Adjustment

Certain applications require output frequencies that are unavailable from the menu of digital selections. For example, an application requires 33 Hz as the second speed (multi-step mode). Note that 33 Hz is not available with digital selection by means of the appropriate DS1 switches. Under these circumstances, the VR2 potentiometer can be used to attain the desired speed. The adjustment range of VR2 is as below:

#### VR2 Function Multi-Step Speed Mode

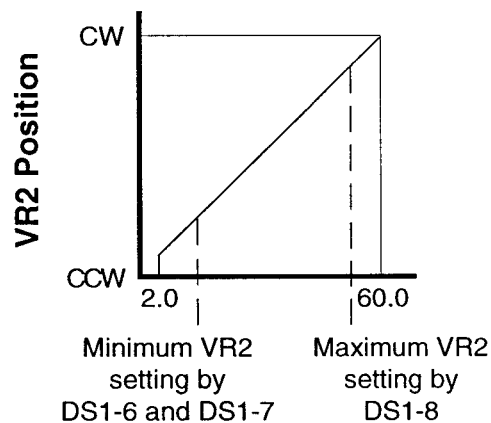

### 6.3.6.3 Special Function of VR3: Multi-Step Third Speed/Upper Limit Adjustment

Certain applications require output frequencies that are unavailable from the menu of digital selections. Note that VR3 has a function in both infinitely variable and multi-step speed control modes. For example, an application requires 55 Hz as the third speed (multi-step mode) or the upper limit (infinitely variable mode). Note that 55 Hz is not available via digital selection by means of the appropriate DS1 switches. Under these circumstances, the VR3 potentiometer can be used to attain the desired speed. The adjustment range of VR3 is as below:

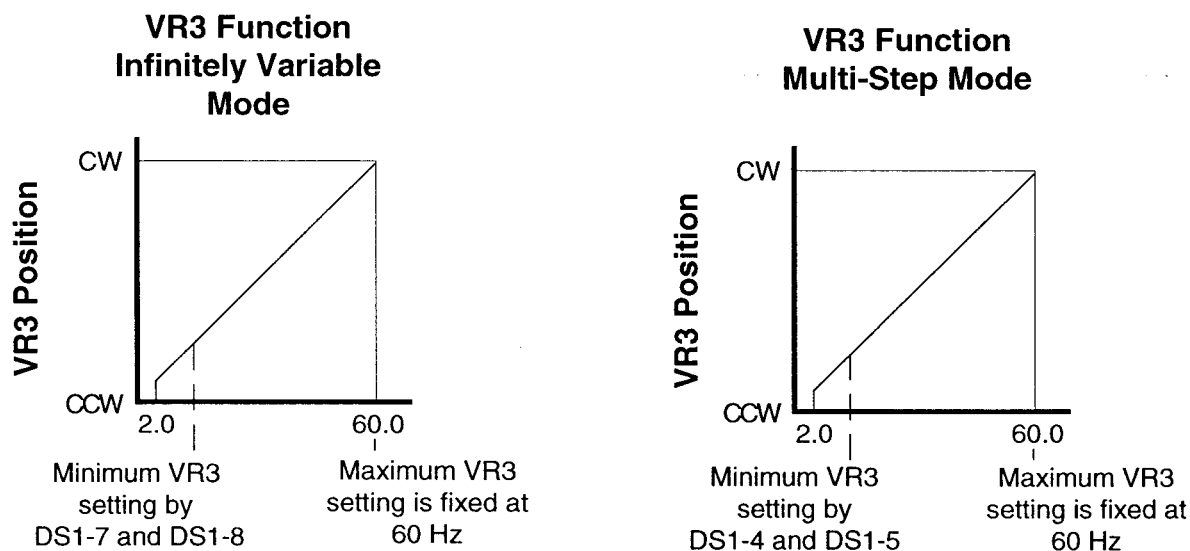



## **Section 7: Checks Before Operation**

After mounting and interconnections are completed, please check for:

- Correct connections.
- Correct input power supply. (No voltage drop or imbalance, source KVA  $\leq$  500.)  
**Please note that 460V input to 230V series control will destroy power section of unit!**
- No short circuit conditions.
- No loose screw terminals. (Check especially for loose wire clippings.)
- Proper load conditions.

### **Precautions:**

- Only start the motor if motor shaft rotation is stopped.
- Even with small loading, never use a motor whose nameplate amperage exceeds the inverter rated current.
- When starting and stopping the motor, be sure to use the operation signals (FWD/REV), not the magnetic contactor on the power supply side.
- **Extreme Caution:**  
**Braking method selection as shipped from Electromotive Systems is set for immediate stop at STOP command (DS1-3 = on). If changed to decelerate at STOP command (DS1-3 = off), then extreme caution should be used during deceleration. If deceleration time is too long, equipment can run into endstop device, causing damage to equipment or injury to personnel.**

## **Section 8: Maintenance**



---

IMPULSE•Sjr. requires almost no routine checks. It will function more efficiently and last longer if it is kept clean, cool and dry, observing precautions listed in Section 2.1. Check for tightness of electrical connections, discoloration or other signs of overheating. During service inspection, turn off AC main circuit power and wait at least ten minutes before touching any circuit components. The red charge lamp must be extinguished before touching any components. Failure to adhere to this warning could result in serious injury.

## Section 9: Troubleshooting

### 9.1 Failure Indications of IMPULSE•Sjr.

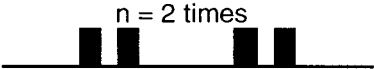
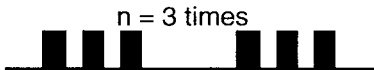
If IMPULSE•Sjr. malfunctions, the fault lamp (white LED, visible through plastic cover) blinks on and off. The blinking sequence tells the user the type of fault that has occurred.

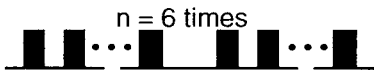
Blinking Sequence	Probable Cause	What to Do
	<b>Instantaneous Overcurrent Protection</b> <ul style="list-style-type: none"> <li>• Accel/decel time is set too short.</li> <li>• Load too heavy.</li> <li>• Power factor capacitor connected to IMPULSE•Sjr. output.</li> <li>• Incorrect V/f pattern selection.</li> <li>• IMPULSE•Sjr. output transistor is shorted or ground fault condition exists.</li> </ul>	<ul style="list-style-type: none"> <li>• Extend accel/decel time.</li> <li>• Run motor without load. Check load conditions.</li> <li>• Remove power factor capacitors.</li> <li>• Select the optimum V/f pattern via RDS3.</li> <li>• IMPULSE•Sjr. output transistor is shorted or motor is grounded. Call Electromotive Systems.</li> </ul>
	<b>Overvoltage Protection</b> <ul style="list-style-type: none"> <li>• Decel time too short.</li> <li>• Input power voltage &gt; specification allows.</li> </ul>	<ul style="list-style-type: none"> <li>• Extend the decel time.</li> <li>• Correct input overvoltage problem.</li> </ul>
	<b>Undervoltage Protection</b> <ul style="list-style-type: none"> <li>• Supply voltage &lt; specification allows.</li> <li>• Momentary power failure (&gt; 15ms).</li> </ul>	<ul style="list-style-type: none"> <li>• Correct the input power supply problem. Check for single phase problem.</li> <li>• Inspect busbar system for collector bounce.</li> </ul>
	<b>Ground Fault</b> <ul style="list-style-type: none"> <li>• Transistor module damaged.</li> </ul>	<ul style="list-style-type: none"> <li>• Replace transistor module.</li> </ul>
	<b>Microcomputer Fault</b> <ul style="list-style-type: none"> <li>• Problem always due to high electrical noise environment.</li> </ul>	<ul style="list-style-type: none"> <li>• Install R-C type suppressors on all contactor/brake coils.</li> </ul>

### 9.2 Troubleshooting Flow Chart

1) Motor will not run.

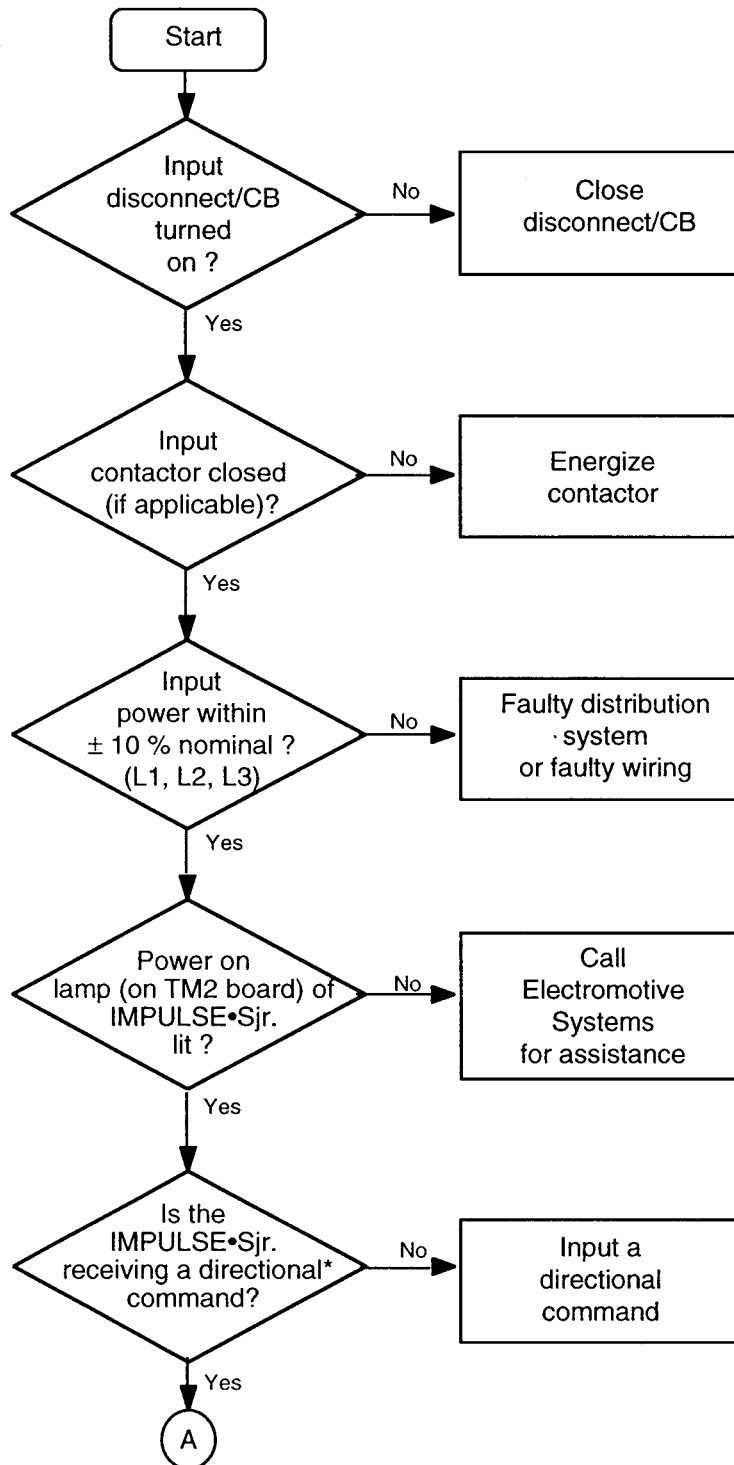

continued

\* Confirm control voltage on proper terminals when RUN command is given

9.2 Troubleshooting Flow Chart (Continued)

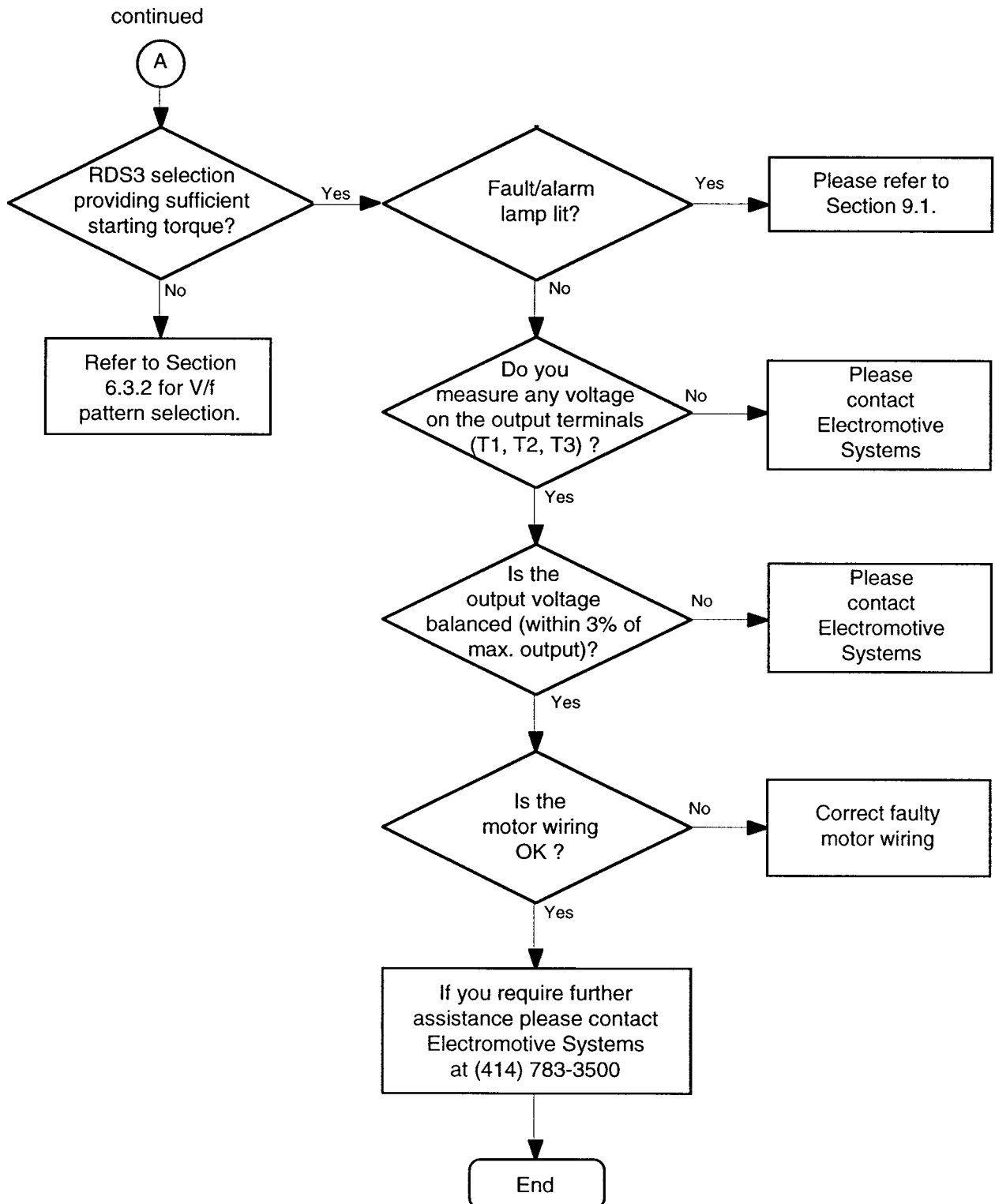

### **9.3 Information Check List**

IMPULSE•Sjr. adjustable frequency controls and *TCONTROLS* motor control panels are designed to perform their tasks flawlessly. Should you encounter problems with Electromotive Systems control products, we invite you to call our customer service department for personal attention. Before calling, please complete the check list on the following page. The information will assist you in successful and expedient discussion with the Electromotive Systems Service Department.

**Electromotive Systems, Inc. phone number: 414-783-3500**

**Electromotive Systems, Inc. fax number: 414-783-3510**

### 9.3 Information Check List (Continued)

#### Control Information:

IMPULSE•Sjr. Model Number: \_\_\_\_\_ *TCONTROLS* Serial Number: \_\_\_\_\_

Setting Values:

RDS1: _____	Fault alarm history: (if any)
RDS2: _____	#1 _____ (#Blinks/Pause)
RDS3: _____	#2 _____ (#Blinks/Pause)
DS1-1 _____	#3 _____ (#Blinks/Pause)
DS1-2 _____	
DS1-3 _____	VR1 _____
DS1-4 _____	VR2 _____
DS1-5 _____	VR3 _____
DS1-6 _____	
DS1-7 _____	
DS1-8 _____	
DS1-9 _____	
DS1-10 _____	

#### Application Information:

Hoist: \_\_\_\_\_ Manufacturer: \_\_\_\_\_

Trolley: \_\_\_\_\_

Bridge: \_\_\_\_\_

Hook Rotate: \_\_\_\_\_

Clamp Op.: \_\_\_\_\_

#### System Information:

Power Supply: _____	Motor(s) Data: _____
Voltage: L1-L2 _____	Hp: _____ Rated Amps: _____
L2-L3 _____	RPM: _____ Aux. Equipment: _____
L1-L3 _____	Rated VAC: _____ 1) Brake _____
Ø: _____ (1Ø, 2Ø, 3Ø?) _____	Model Number: _____ 2) Gearbox _____
Hz: _____	Manufacturer: _____ 3) Other _____
Source KVA: _____	

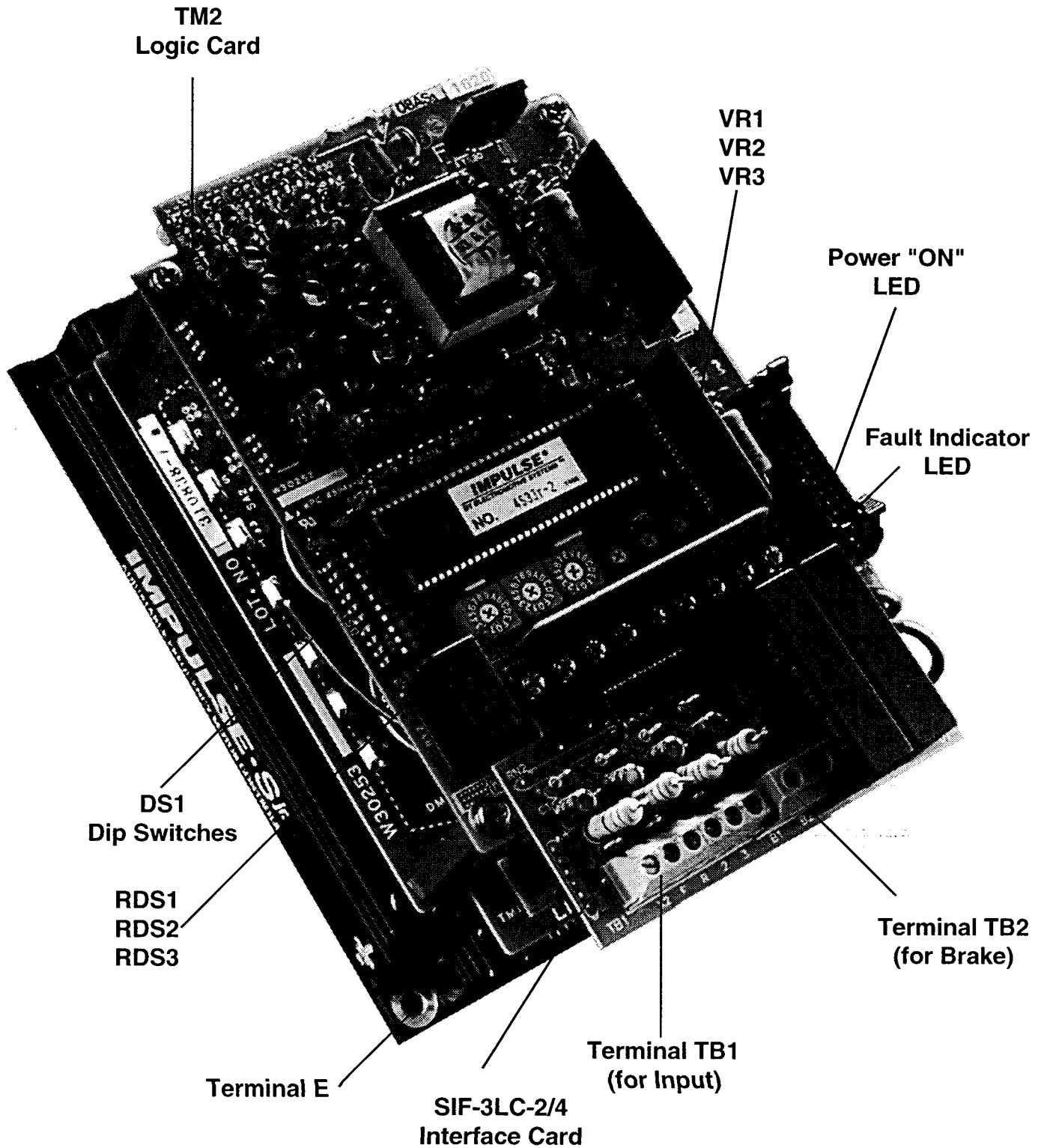



## 9.4 Power Section Test for IMPULSE•Sjr.

**Warning:** To avoid serious injury, the following tests should be made with power to the inverter off, the inverter disconnected and the charge lamp completely extinguished.

- 1) All tests should be done with an analog VOM
- 2) Set analog VOM on Rx1 scale and "zero" meter.
- 3) Locate DC bus on inverter. This can be found at location labeled LW2 (see below). LW2 is located on the top right edge of the control board. (TM2)
- 4) Take readings and compare with information included in sections 9.4.1 and 9.4.2.

Note:

- L1, L2, L3 = inverter input terminals
- T1, T2, T3 = inverter output terminals
- P = positive (+) side of DC bus
- N = negative (-) side of DC bus

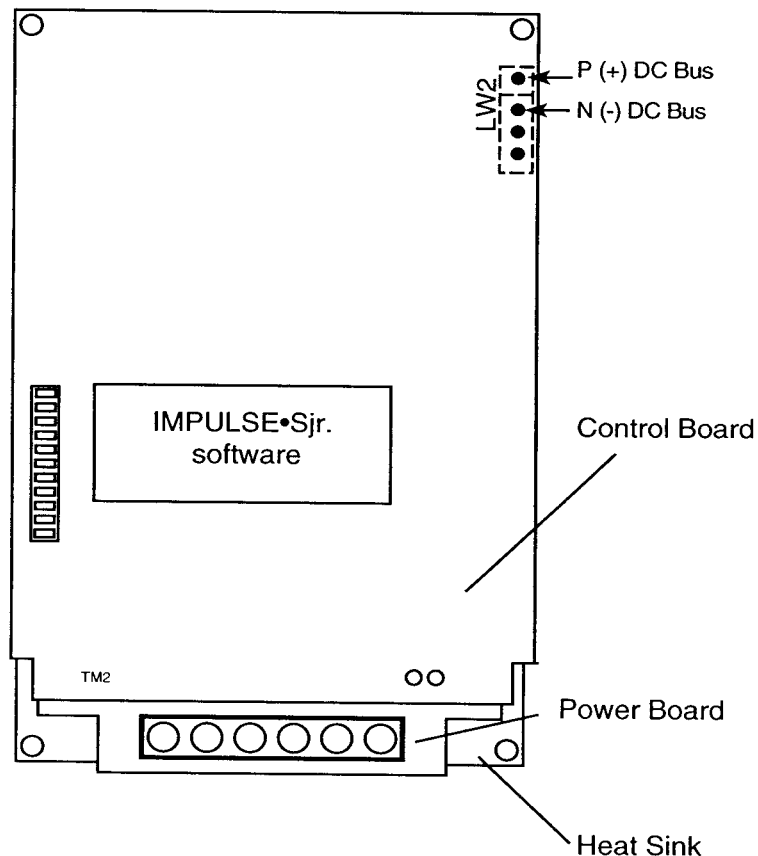

### 9.4.1 Input Rectifier Check

VOM + probe	VOM - probe	Resistance	
		Normal	Abnormal
L1	P	5 - 80 Ω	0 or ∞
L2	P	5 - 80 Ω	0 or ∞
L3	P	5 - 80 Ω	0 or ∞
P	L1	∞	≠ ∞
P	L2	∞	≠ ∞
P	L3	∞	≠ ∞
L1	N	∞	≠ ∞
L2	N	∞	≠ ∞
L3	N	∞	≠ ∞
N	L1	5 - 80 Ω	0 or ∞ *
N	L2	5 - 80 Ω	0 or ∞ *
N	L3	5 - 80 Ω	0 or ∞ *

\* A reading of ∞ indicates a pre-charge resistor is open.

## 9.4.2 Output Transistor Check

VOM + probe	VOM - probe	Resistance	
		Normal	Abnormal
T1	P	5 - 80 $\Omega$	0 or $\infty$
T2	P	5 - 80 $\Omega$	0 or $\infty$
T3	P	5 - 80 $\Omega$	0 or $\infty$
P	T1	$\infty$	$\neq \infty$
P	T2	$\infty$	$\neq \infty$
P	T3	$\infty$	$\neq \infty$
T1	N	$\infty$	$\neq \infty$
T2	N	$\infty$	$\neq \infty$
T3	N	$\infty$	$\neq \infty$
N	T1	5 - 80 $\Omega$	0 or $\infty$
N	T2	5 - 80 $\Omega$	0 or $\infty$
N	T3	5 - 80 $\Omega$	0 or $\infty$

### Application of the External Braking Resistor (via Con10)

Certain applications demanding extensive braking capability will require the optional external braking resistor. When applied, this option permits the load to be stopped more quickly, or permits a higher inertial load to be stopped properly. The use of the optional external braking resistor should be discussed with Electromotive Systems engineering personnel.

The part number, outline dimensions, and mounting arrangement of the external braking resistor is given below:

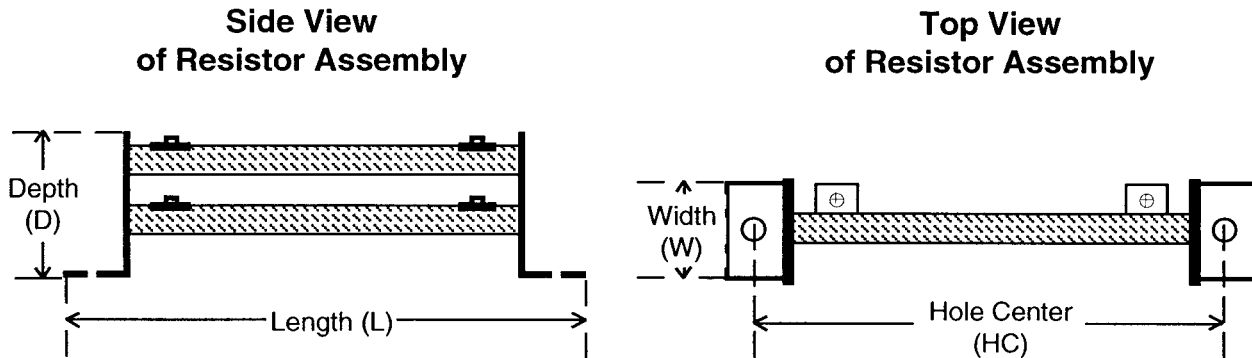

Model Number	External Resistor P/N	L	W	D	HC	Hole Diameter
230AFD1-Sjr	DB2-1	5.625 (143)	1.125 (29)	2.375 (60)	5.00 (127)	0.218 (5.5)
230AFD2-Sjr						
230AFD3Sjr	DB2-2	8.125 (206)	1.375 (35)	3.44 (87)	7.50 (190)	
230AFD5-Sjr	DB2-3					
460AFD1-Sjr	DB4-1	5.625 (143)	1.125 (29)	2.375 (60)	5.0 (127)	0.218 (5.5)
460AFD2-Sjr	DB4-2	8.125 (206)	1.375 (35)	3.44 (87)	7.50 (190)	
460AFD3-Sjr						
460AFD5-Sjr	DB4-3					
460AFD7.5-Sjr	DB4-5	10.375 (263)	1.875 (48)	4.375 (111)	9.50 (241)	0.278 (7)
460AFD10-Sjr						

## Application of Optional Input and Output Reactors

### Input Reactors:

As discussed in Section 3.2.6, the Source KVA of the electrical supply must not exceed 500KVA. The Source KVA is essentially defined as the main transformer rating for the area in which the IMPULSE•Sjr. is located. Modern buildings often have a single, very large transformer serving an entire manufacturing facility. (often in the past, many smaller transformers were located throughout a given facility.)

Installation of an input reactor is an effective countermeasure for a large Source KVA. Section 3.2.6 provides the necessary part numbers; this addendum advises Electromotive Systems' suggested electrical connections.

### Output Reactors:

As briefly mentioned in Section 3.2.6, certain wound rotor motor applications require the use of output reactors to protect the drive transistors. This potential difficulty is caused by the low value of wound rotor motor impedance relative to the power rating of the motor. Use of an output reactor increases the impedance seen by the IMPULSE•Sjr.'s output transistors. Another possible problem relates to the "reflected wave" phenomenon that effectively doubles the voltage of the first turn of the motor winding when the cable length between the IMPULSE•Sjr. and the motor terminals exceeds 100' (30 meters). While the "reflected wave" situation will not damage the IMPULSE•Sjr., the insulation life of the motor windings could be shortened.

the installation of an output reactor is an effective countermeasure for both low impedance problems and the "reflected wave" phenomenon. Section 3.2.6.2 provides the necessary part numbers; this appendix advises Electromotive Systems' suggested electrical connections.

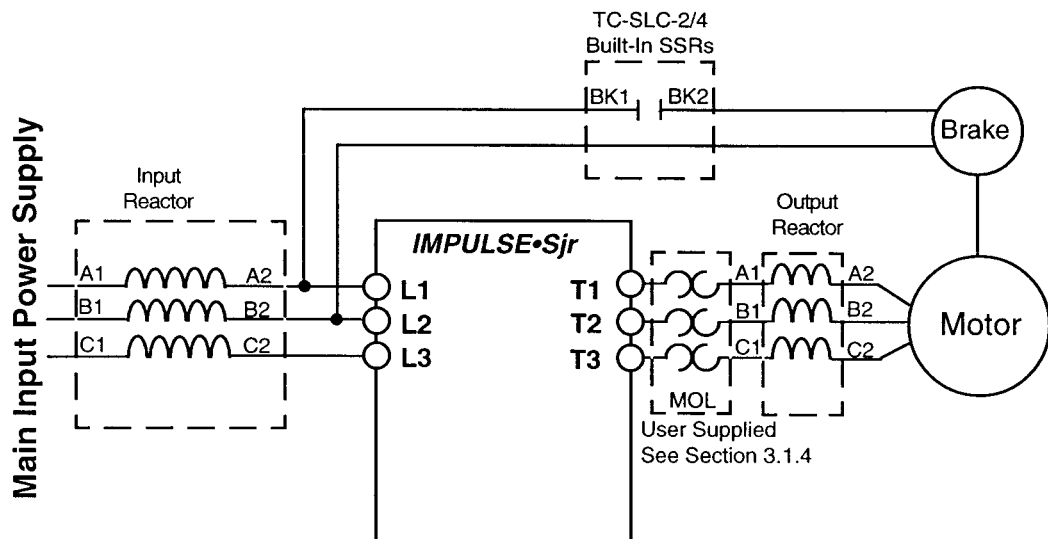

- 1) Use surge absorbers (R-C networks) on all relay and contactor coils.
- 2) Shielded cable shall be used for all low level D.C. speed reference signals (0-10VDC, 4-20 mA). Shield should be grounded only at the AF drive side.
- 3) Use a minimum of #16 AWG for control wiring, and #12 AWG (or larger) for power wiring. Size according to N.E.C. table 310-16.
- 4) The following is required for all dual motor bridge cranes and suggested for center driven cranes, trolleys and hoists. Upsize the wiring one size for every 25 feet of distance between AF drive and motor to account for voltage drop (which becomes significant at low frequencies).
- 5) Use time delay fuses for AF drive input protection. They shall be sized at approximately 150% of AF drive continuous rated amperage.
- 6) Control and power wiring (including dynamic braking resistor wiring) shall be kept separate on terminal block strip.
- 7) Keep control (directional and speed command inputs to the AF drive) and power wiring from running together in parallel paths on the panel or in conduit runs. Keep control and power festoon wiring in different cables and separated.
- 8) If control and power wiring do meet on a panel, cross them perpendicularly.
- 9) Before applying power to the AF drive, check the output circuit (T1, T2, T3) for possible short circuits or ground faults.
- 10) Always mount the AF drive in its proper (vertical) orientation with at least 3" of clearance on all four sides. AF drives should be housed in appropriate NEMA rated enclosures for the environment in which they will be used.
- 11) Keep AF drive heatsink clear of any obstructions (components on panel) to ensure proper cooling air flow.
- 12) If using externally mounted interface boards, or remotely mounted speed reference signals, use shielded cable from the interface output or remote speed reference to the AF drive control input terminals.
- 13) On external input devices (control), hard contact inputs are preferred rather than solid state inputs into the control voltage input boards (TC-GIF\_\_, TC-SIF\_\_, TC-SLC\_\_).
- 14) If the input device is a PLC triac output, a 5K ohm, 10 watt resistor may have to be used between the signal and L2 (X2).
- 15) AF drives should always have the cover mounted on unit during normal operating conditions to protect the digital operator (Specific to Electromotive Systems IMPULSE•G Series, IMPULSE•VG Series and IMPULSE•P series).

- 16) All ground terminals or screws ("G" or "E") must be grounded back to earth ground.
  - 17) If the power source is greater than 500 KVA, there should be at least 3% impedance in the line between the source and the input to the AF drive.
  - 18) Incoming power supply voltage must be limited to 230 volts  $\pm$  10% or 460 volts  $\pm$  10%.
  - 19) On existing wound rotor motor applications >25HP, a line reactor of 3% impedance shall be required on the load side of the AF drive. (Specific to Electromotive Systems IMPULSE•G Series, IMPULSE•VG Series, and IMPULSE•P series).
  - 20) When using more than one transformer for control power, properly phase each transformer with respect to other(s).
  - 21) All line and ground wiring should be disconnected when any welding is being done on or to the crane.
  - 22) When using the Impulse•S Series AF drive on existing wound rotor motor applications oversizing the drive or installing a load reactor is suggested to avoid over-current conditions upon starting a motor.
  - 23) When supplying single phase input to the AF drive, the amperage of the drive must be derated by approximately one-half. (Consult Electromotive Systems.)
  - 24) All worm gear box hoist applications require dynamic braking resistors to avoid overvoltage conditions when lowering the hook.
  - 25) Sliding collector bars are not to be used between the drive and the motor. It must be hard wired (i.e. festoon cable).
- \*\* If there are any questions, or a further explanation of the above recommendations is needed, please contact Electromotive Systems at 414/783-3500 before proceeding.
- \*\* The above recommendations, if followed, will help to ensure trouble-free start-up and successful operation of the adjustable frequency drive when applied to overhead material handling equipment.