



ELECTROMOTIVE SYSTEMS, INC.

IMPULSE® P3

ADJUSTABLE FREQUENCY MOTOR CONTROLS

INSTRUCTION MANUAL



Contents

Section 1: Introduction	2
1.1 General	2
Section 2: Installation	3
2.1 Location	3
2.2 Positioning	4
2.3 Mounting Dimensions – in inches	5
2.4 Specifications	6
2.5 The Importance of the Proper Relationship between Voltage and Frequency	8
Section 3: Wiring	9
3.1 Main AC Power Interconnections	9
3.1.1 Input Fuse or Circuit Breaker Selection	10
3.1.2 Wire Size	10
3.1.3 Grounding	11
3.1.4 Motor Thermal Overload Relay (When Used)	11
3.1.5 Motor Brake Magnetic Contactor	12
3.1.6 Magnetic Mainline Contactor	12
3.1.7 Special Warnings for Power Semi-Conductors	12
3.2 Control Circuit Interconnections	13
3.2.1 Wire Size	15
3.2.2 Direction and Speed Selection Input Commands	15
3.2.3 Motor Brake Interlock Output Command	15
3.2.4 Motor Thermal Overload Relay (When Used)	16
3.2.5 Multi-Function Output Contacts	16
3.2.6 Additional Wiring Precautions	16
3.2.6.1 R-C Surge Absorber Specifications	17
3.2.6.2 AC Reactor Specifications	17
Section 4: Digital Keypad	18
4.1 Keypad Layout and Key Functions	18
4.2 Programming Mode Key Functions	19
4.3 Local Operation Control Mode Key Functions	20
4.4 Passive Cover Option	23
4.5 IMPULSE•P ³ Passive Cover Display and Status	24

Table of Contents

Section 5: To Begin Programming	25
5.1 What is a Constant?	25
5.2 Access to the Various Constants	25
5.3 X-Press Programming™– Programming the Easy Way	26
5.4 IMPULSE•P ³ Constant Descriptions	27
5.5 Enabling Program Mode	36
5.5.1 How to Change the Minimum Operating Speed (Constant no-03)	37
5.5.2 How to Change Accel/Decel Time (Constant no-08/Constant no-09)	38
Section 6: Control Flexibility	39
6.1 Speed Control Method Definitions (X-Press by Constant no-00)	40
6.1.1 Two-Speed Multi-Step Speed Control Method (X-Press by Constant no-00 = 00 or 05)	41
6.1.2 Three-Speed Multi-Step Speed Control Method (X-Press by Constant no-00 = 01 or 06)	42
6.1.3 Five-Speed Multi-Step Speed Control Method (X-Press by Constant no-00 = 02 or 07)	43
6.1.4 Two-Step Infinitely Variable Speed Control (X-Press by Constant no-00 = 03 or 08)	45
6.1.5 Infinitely Variable Speed Control Method (Three-Step Type) (X-Press by Constant no-00 = 04 or 09)	47
6.2 Stopping Method Definitions (Constant no-13, Digit 3 which is changed by setting of no-00)	48
6.2.1 Immediate Stop at STOP Command	49
6.2.2 Decelerate at STOP Command	49
Section 7: Setting Recipes	50
7.1 Two-Speed Multi-Step Control Method (X-Press Constant no-00 or 05)	50
7.1.1 Control Circuit Wiring Diagram for Two-Speed Multi-Step Control	50
7.1.2 Control Circuit Input Sequence for Multi-Step Speed Control	51
7.1.3 X-Press Settings for Other Constants (Two-Speed Multi-Step Control)	51
7.2 Three-Speed Multi-Step Control Method (X-Press Constant no-00 = 01 or 06)	53
7.2.1 Control Circuit Wiring Diagram for Three-Speed Multi-Step Control	53
7.2.2 Input/Output Reference for Three-Speed Multi-Step Control	54
7.2.3 X-Press Settings for Other Constants (Three-Speed Multi-Step Control)	55
7.3 Five-Speed Multi-Step Control Method (X-Press Constant no-00 = 02 or 07)	56

Table of Contents

7.3.1 Control Circuit Wiring Diagram for Five-Speed Multi-Step Control	56
7.3.2 Input/Output Reference for Five-Speed Multi-Step Control	57
7.3.3 X-Press Settings for Other Constants (Five-Speed Multi-Step Control)	58
7.4 Two-Step Infinitely Variable Control Method (X-Press Constant no-00 = 03 or 08)	59
7.4.1 Control Circuit Wiring Diagram for Two-Step Infinitely Variable Control	59
7.4.2 Control Circuit Input Sequence for Two-Step Infinitely Variable Speed Control	60
7.4.3 X-Press Settings for Other Constants (Two-Step Infinitely Variable Control)	61
7.5 Three-Step Infinitely Variable Control Method (X-Press Constant no-00 = 04 or 09)	62
7.5.1 Control Circuit Wiring Diagram for Three-Step Infinitely Variable Control	62
7.5.2 Control Circuit Input Sequence for Three-Step Infinitely Variable Speed Control	63
7.5.3 X-Press Settings for Other Constants (Three-Step Infinitely Variable Control)	64
7.6 To Enable/Disable Electronic Motor Thermal Overload Protection	65
Section 8: Special Features of IMPULSE•P³	66
8.1 Safe Operating Windows™	66
8.2 Safety Features of IMPULSE•P ³	68
8.2.1 STOP Button Operation	68
8.2.2 RUN Button Operation	68
8.2.3 Automatic Keypad Lockout	69
8.3 Quick Stop	69
8.3.1 Quick Stop Programming Method	69
8.3.2 Quick Stop Timing Chart	69
8.4 Reverse Plug Simulation	70
8.4.1 Reverse Plug Simulation Programming Method	70
8.4.2 Reverse Plug Simulation Timing Chart	70
8.5 Swift Lift Overspeed Operation	71
8.5.1 Swift Lift Programming Method	71
8.5.2 Swift Lift Flow Chart	72
Section 9: Checks Before Operation	73
Section 10: Maintenance	74

Table of Contents

Section 11: Troubleshooting.....	75
11.1 Troubleshooting 101- Where to Begin	75
11.1.1 Troubleshooting for Symptom #1 - Equipment Will Not Operate	76
11.1.2 Troubleshooting for Symptom #2 - Equipment Operates, but Operation is Either Intermittent or not Acceptable	78
11.2 Possible Solutions to Common Fault Codes	78
11.3 Listing of Fault Codes	80
 Appendix 1: Recommended Wiring Practices	 83
 Appendix 2: External Resistor Specifications	 85
IMPULSE•P ³ External Resistor Specifications	85
 Appendix 3 Limited Warranty	 86
Service	86
On-Call Service	86
Identifying Your Drive	86
Service Policy	87
Electromotive Systems Limited Warranty	88

Thank You!

ELECTROMOTIVE SYSTEMS, INC. appreciates your purchase of this IMPULSE•P³ adjustable frequency drive. When properly installed, operated and maintained, the IMPULSE•P³ will provide a lifetime of reliable operation. It is MANDATORY that the person who operates, inspects, and maintains this equipment thoroughly read and understand this manual.

This instruction manual has been designed to serve as a self-supporting guide for the proper installation, operation, and maintenance of the IMPULSE•P³ adjustable frequency drive. If you require additional assistance, please feel free to contact either your local supplier or Electromotive Systems by phone at 800/288-8178 or by fax at 414/783-3510.

NOTE: Throughout this instruction manual IMPULSE•P³ will be referred to as an adjustable frequency drive, drive or inverter. All references should be considered as one in the same.

 **D A N G E R**

Do NOT touch any circuit components while AC main power is on or immediately after the main AC power is disconnected from the unit. You must first wait until the red “CHARGE” lamp adjacent to the main power terminal strip is extinguished. It may take as long as 10 minutes for the charge on the main DC bus capacitors to drop to a safe level. Failure to adhere to this warning could result in serious injury.

Section 1: Introduction

1.1 General

IMPULSE•P³ represents a significant advance in adjustable frequency motor controls utilizing microprocessor-based digital control of all functions and settings. Modifications and adjustments are easily performed using the digital keypad.

IMPULSE•P³ incorporates a high performance Pulse Width Modulated (PWM) design generating a variable voltage - variable frequency output that closely approximates a sinusoidal current waveform to allow variable speed control of any conventional squirrel cage, three-phase induction motor.

IMPULSE•P³ is a unique hardware and software configuration specifically designed for application to crane, hoist and monorail systems. This product is a direct result of years of experience in applying adjustable frequency drives to satisfy the demanding requirements of this market.

Section 2: Installation

Special Note: If you purchased this IMPULSE•P³ as part of an Electromotive Systems pre-engineered, TCONTROLS[®] motor control panel, you should skip Sections 2 and 3 and proceed directly to Section 4.

2.1 Location

Proper location of the IMPULSE•P³ is imperative to achieve optimum performance and a normal operating life. These units should always be installed in areas where the following conditions exist:

- Ambient operating temperature: +14~104°F (-10~ +40°C).
- Protected from rain and moisture.
- Protected from corrosive gases or liquids.
- Sheltered from direct sunlight.
- Free from metallic particles or excessive airborne dust.
- Free from excessive vibration (see specifications).

2.2 Positioning

For cooling and maintenance purposes, make sure that there is sufficient clearance around the IMPULSE•P³ whether it is enclosed in a cabinet or not, as shown below. To maintain effective air flow/cooling, IMPULSE•P³ must be installed with heatsink ribs oriented vertically.

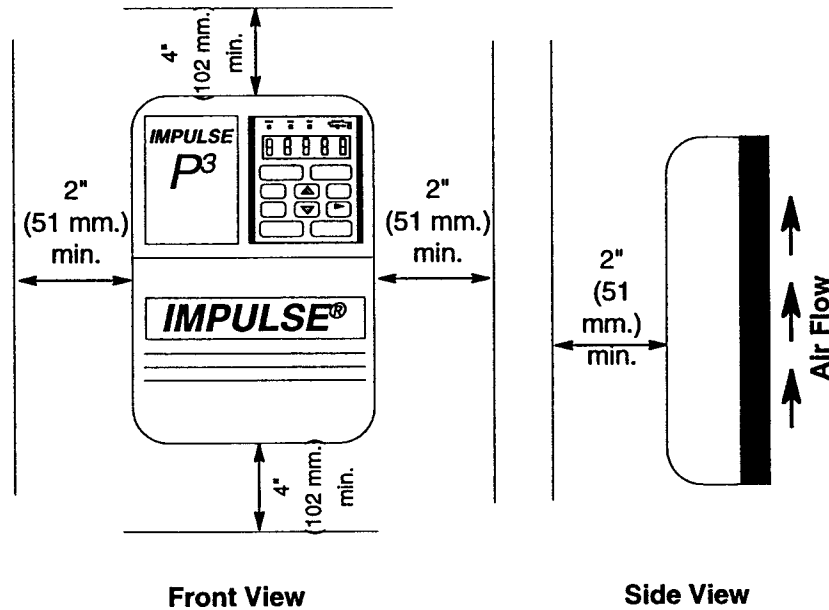

2.3 Mounting Dimensions – in inches

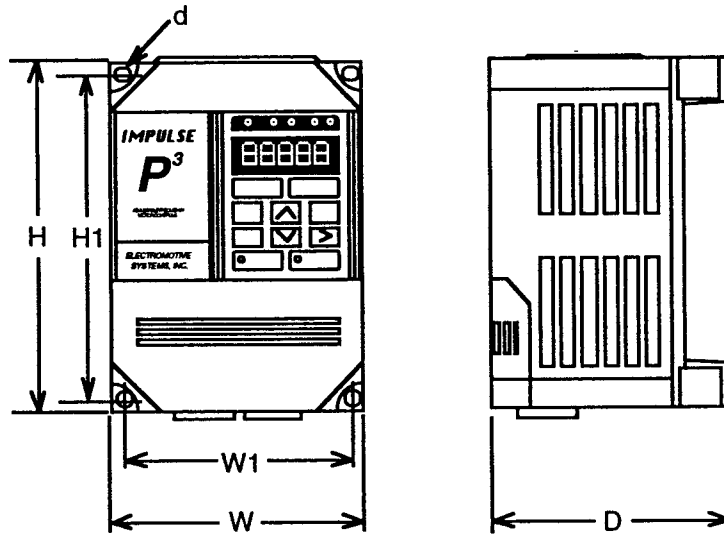

Class	Model Number	H	H1	W	W1	D	d
230V	230AFD1-P3	5.91	5.43	5.51	5.04	5.45	0.20
	230AFD2-P3						
	230AFD3-P3	7.87	7.32		4.96	6.69	0.22
	230AFD5-P3						
460V	460AFD1-P3	7.87	7.32	5.51	4.96	6.69	0.22
	460AFD2-P3						
	460AFD3-P3		7.28	7.48	6.89	7.48	0.23
	460AFD5-P3						

2.4 Specifications

	Input Voltage	200 to 230 Volts				380 to 480 Volts				
	Model Number	230 AFD (Hp Rating) P ³				460 AFD (Hp Rating) P ³				
	Horsepower*	1	2	3	5	1	2	3	5	
Output Characteristics	kW	0.75	1.5	2.2	3.7	0.75	1.5	2.2	3.7	
	Full Load Amps- Traverse Motions CMAA Class A, B, C	5.6	7.3	12.3	19.6	2.9	4.5	5.4	9.0	
	Full Load Amps- Traverse Motions CMAA Class D	5.0	6.5	11.0	17.5	2.6	4.0	4.8	8.0	
	Full Load Amps- Hoist Motions with Mechanical Load Brakes CMAA Class A, B, C and D	5.0	6.5	11.0	17.5	2.6	4.0	4.8	8.0	
	Full Load Amps- Worm Gear Hoists	4.0	5.0	8.3	13.0	2.0	3.0	4.0	6.0	
	Maximum output voltage	3-Phase 200/208/220/230V (Proportional to input voltage)				3-Phase 380/400/415/460V (Proportional to input voltage)				
	Output frequency range	1.5 to 150 Hz (Maximum frequency for V/f pattern is programmable between 50 and 150 Hz.)								
Power Supply	Rated input voltage and frequency	3-Phase 200/208/220V, 50/60 Hz				3-Phase 380/400/415/440/460V, 50/60 Hz				
	Allowable voltage fluctuation	±10%								
	Allowable frequency fluctuation	±5%								
Control Characteristics	Control Method	Sine wave PWM								
	Control Commands	Commanded by a 16-bit microprocessor through a fully programmable proprietary EPROM								
	Frequency Control Range	40 to 1 (frequency range that allows for a minimum 150% torque)								
	Frequency Accuracy	Digital command: 0.01% (+14 to 104°F, -10 to 40°C) Analog command: 0.1% 77±8°F, 25±10°C)								
	Frequency Setting Signal	Digital (dry circuit contact closure) Analog [(0 to 10 VDC (20KW), 4-20mA (250W))]								
	Accel/Decel Time	0.1 to 25.5 sec (accel/decel set independently)								
	Braking Torque	Approximately 20% (up to approximately 150% can be obtained with optional dynamic braking resistor package)								
	V/Patterns	Programmable								

* Rated horsepower is based on an 1800 RPM NEMA B squirrel cage motor. Drives should be sized according to actual full load amps based on CMAA Class. However, drive rated horsepower should never be less than motor rated horsepower.

2.4 Specifications–(Continued)

	Input Voltage	200 to 230 Volts				380 to 480 Volts			
	Model Number	230 AFD (Hp Rating)•P ³				460 AFD (Hp Rating)•P ³			
	Horsepower*	1	2	3	5	1	2	3	5
Protective Functions	Instantaneous Overcurrent	Inverter output is shut off at 200% rated current							
	Overload	150% of continuous output current rating for one minute							
	Motor Overload Protection	Provided by electronic thermal overload circuit							
	Overvoltage	If DC bus voltage exceeds 410V				If DC bus voltage exceeds 800V			
	Undervoltage	If DC bus voltage drops to 210V or below				If DC bus voltage drops to 420V or below			
	Fin Overheat	Provided by thermostat							
	Ground Fault	Provided by electronic circuit							
	Power Charge Indication	Charge lamp stays ON until DC bus drops to 50V							
Environmental Conditions	Location	Indoor (protected from corrosive gases and dust)							
	Ambient Temperature	+14 to 104°F (-10 to +40°C)							
	Humidity	90% RH (no condensation)							
	Vibration	1G less than 20 Hz, up to 0.2G at 20 to 50 Hz							

* Rated horsepower is based on an 1800 RPM NEMA B squirrel cage motor. Drives should be sized according to actual full load amps based on CMAA Class. However, drive rated horsepower should never be less than motor rated horsepower.

2.5 The Importance of the Proper Relationship between Voltage and Frequency

The IMPULSE•P³ unit varies the speed of the motor by varying the frequency of the power being applied to the motor. If you only vary the frequency without changing the motor voltage, the motor torque will vary greatly. To ensure the motor is capable of producing full load torque, the IMPULSE•P³ must also vary the output voltage.

The motor was designed for operation at the voltage and frequency listed by the manufacturer on its nameplate. Maintaining the design relationship between voltage and frequency will allow the motor to produce design torque, without excessive heating. This design relationship is normally described by a volts/hertz (V/F) ratio. Ideally, maintaining the design V/F ratio will maintain the magnetic fields within the motor at their design value, regardless of the speed of operation. The end result dictates that if you wish to operate a motor rated 460 VAC at 60Hz at half speed, the output frequency must be half (30 Hz) and the output voltage will be half (230 VAC).

Because the voltage drop between the output terminals of IMPULSE•P³ and the motor are particularly significant at lower frequencies, a small offset voltage must be applied to the motor if torque demands are high. This voltage offset is typically referred to as *voltage boost*. To accommodate the differences between different motor designs, the amount of voltage boost must be variable.

As you might expect, improper selection of the V/F pattern can result in loss of motor torque or excessive motor currents, so it is vital to select the proper pattern. Please follow these basic guidelines:

- The V/F pattern must be modified to match the motor nameplate. The initial V/F pattern is programmed for a 60Hz motor.
- To minimize the motor currents and heating, use the lowest amount of voltage boost (V/F pattern) that satisfies the starting/accelerating demands of your application.
- Typically, a hoist application will require a higher voltage boost than a bridge or trolley application.

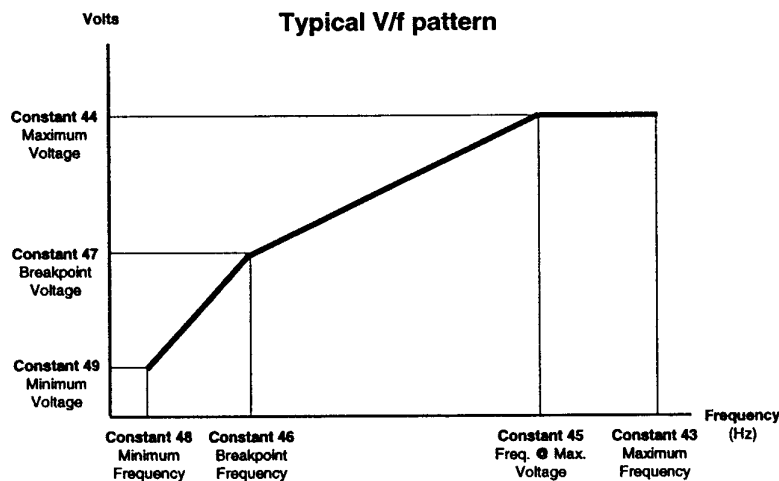

Section 3: Wiring

NOTE: If you purchased this IMPULSE•P³ as part of an Electromotive Systems pre-engineered, TCONTROLS motor control panel, you should skip Section 3 and proceed directly to Section 4.



CAUTION

Section 3 provides Electromotive Systems' recommendations regarding the power and control wiring of the IMPULSE•P³ unit. However, these are only suggestions. You must follow the NEC and your local applicable codes whenever making any of the interconnections to this unit.

3.1 Main AC Power Interconnections

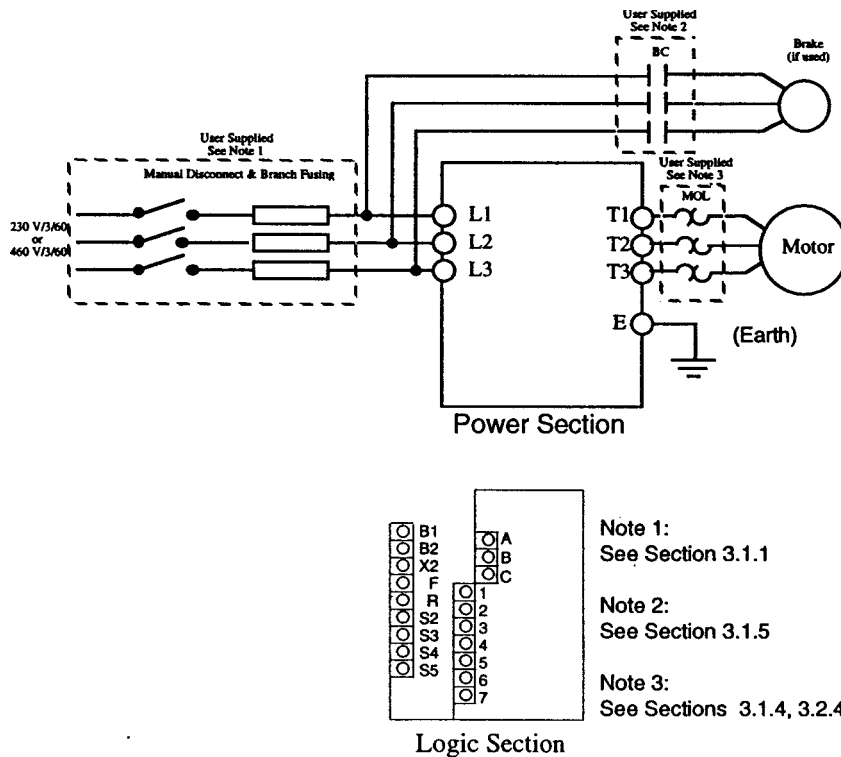

3.1.1 Input Fuse or Circuit Breaker Selection

You should have some disconnecting means and branch circuit protection between the incoming three-phase power supply and the IMPULSE•P³. This branch circuit protection can either be in the form of a thermal magnetic, Molded Case Circuit Breaker (MCCB) or dual element “slow blow” type fuses. The table below shows the suggested ratings for each of the IMPULSE•P³ models.

CAUTION

Section 3 provides Electromotive Systems’ recommendations regarding the power and control wiring of the IMPULSE•P³ unit. However, these are only suggestions. You must follow the NEC and your local applicable codes whenever making any of the interconnections to this unit.

Model Number	230 AFD (Hp)–P3				460 AFD (Hp)–P3			
	Horsepower	1	2	3	5	1	2	3
Rated 3Ø output current (A)	5.0	6.5	11	17.5	2.6	4.0	4.8	8.0
Molded case circuit breaker (MCCB) rating (A)	15	15	20	30	5	10	10	20
Input fuses (A)*	8	10	15	25	4	6	7	12

* Use rejection type fuses, class J or class CC, with time delay.

3.1.2 Wire Size

The table below shows the suggested wire size for each of the IMPULSE•P³ models.

CAUTION

Section 3 provides Electromotive Systems’ recommendations regarding the power and control wiring of the IMPULSE•P³ unit. However, these are only suggestions. You must follow the NEC and your local applicable codes whenever making any of the interconnections to this unit.

Model Number	230 AFD (Hp)–P3				460 AFD (Hp)–P3				
	Horsepower	1	2	3	5	1	2	3	5
3Ø Input Circuit Wire Size (L1, L2, L3) Minimum AWG	12 AWG	12 AWG	12 AWG	12 AWG	12 AWG	12 AWG	12 AWG	12 AWG	12 AWG
Rated 3Ø Output Current (A)	5.0	6.5	11	17.5	2.6	4.0	4.8	8.0	
Output Circuit Wire Size (T1, T2, T3) Minimum AWG	12 AWG	12 AWG	12 AWG	12 AWG	12 AWG	12 AWG	12 AWG	12 AWG	

3.1.3 Grounding

Connect a positive ground using terminal E on the drive chassis.

- Wire size should be at least 14 AWG. The lead length should be kept as short as possible.
- Ground resistance should be 100 ohm or less.
- Never ground the IMPULSE•P³ along with welding machines, large current machines, etc. Run the ground for the IMPULSE•P³ in a separate conduit.
- Where several IMPULSE•P³ units are used together, all of them should be directly grounded to a common ground pole. Be careful to ensure that you do not form a loop with the ground wires.

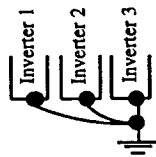

Good

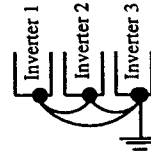

Bad

3.1.4 Motor Thermal Overload Relay (When Used)

To prevent the motor from overheating, IMPULSE•P³ can be programmed to provide motor overload protection.

When multiple motors are being operated in parallel using a single IMPULSE•P³, separate thermal overload relays may be used to provide motor overload protection for each motor. In this case, programmable, electronic motor overload protection may be disabled.

A thermal overload relay is not required when the motor(s) has thermal detector(s) embedded in its windings. Because operating fan-cooled motors at low speeds may overheat the motor (even at rated current), the use of thermal detectors in the motor is recommended when using IMPULSE•P³ with fan cooled motors. Although this is not the case with non-ventilated type motors, thermal detectors will always provide a level of protection not available with conventional thermal overload relays. It is recommended that programmable overload protection be enabled and utilized even when motor thermal detectors are provided.

3.1.5 Motor Brake Magnetic Contactor

IMPULSE•P³ generates a variable voltage output (dependent on output frequency). For this reason, a magnetic contactor (BC) must be installed to provide the motor brake with line power (see Section 3.2).

NOTE: When using a motor brake in conjunction with IMPULSE•P³, the brake power supply must be from the commercial supply, not derived from the IMPULSE•P³ output terminals.

- Section 3.2 shows a typical wiring scheme for use with a three phase motor brake. The capacity of the output relay (250VAC/1Amp) is normally insufficient for directly operating the brake coil. We suggest that an intermediate contactor for brake operation be applied.
- We strongly recommend the use of a suitable surge absorber across the brake coil(s) to prevent excessive voltage transients when the coil is de-energized. For AC coil brakes, you should use an R-C type (not MOV type) suppressor. For DC coil brakes, you should use a diode type suppressor.

3.1.6 Magnetic Mainline Contactor



NEVER connect a magnetic contactor between the motor and the IMPULSE•P³ output terminals (T1, T2, T3). Opening of such a contactor while the unit is driving a motor will result in a large transient voltage that could result in power device failure. Closing of such a contactor after the unit is running will result in a large locked rotor inrush current that could eventually weaken the power devices.

If a mainline, input magnetic contactor is used, it should be wired to provide line power to the input terminals of the IMPULSE•P³ (or multiple units in separate branch circuits) when the contactor coil is energized via a typical momentary/maintained on/off control circuit.

3.1.7 Special Warnings for Power Semi-Conductors

- **Never wire the incoming AC power (230 Volt or 460 Volt) to the output terminals (T1, T2, T3). Applying this voltage to the IMPULSE•P³ output will destroy the unit.**
- Never connect power factor correction capacitors across the output terminals (T1, T2, T3) of the unit.
- Ensure there are not short circuits on the IMPULSE•P³ output terminals.
- Never megger the motor leads while the IMPULSE•P³ is connected. The semi-conductors are vulnerable to high, transient voltages.

3.2 Control Circuit Interconnections

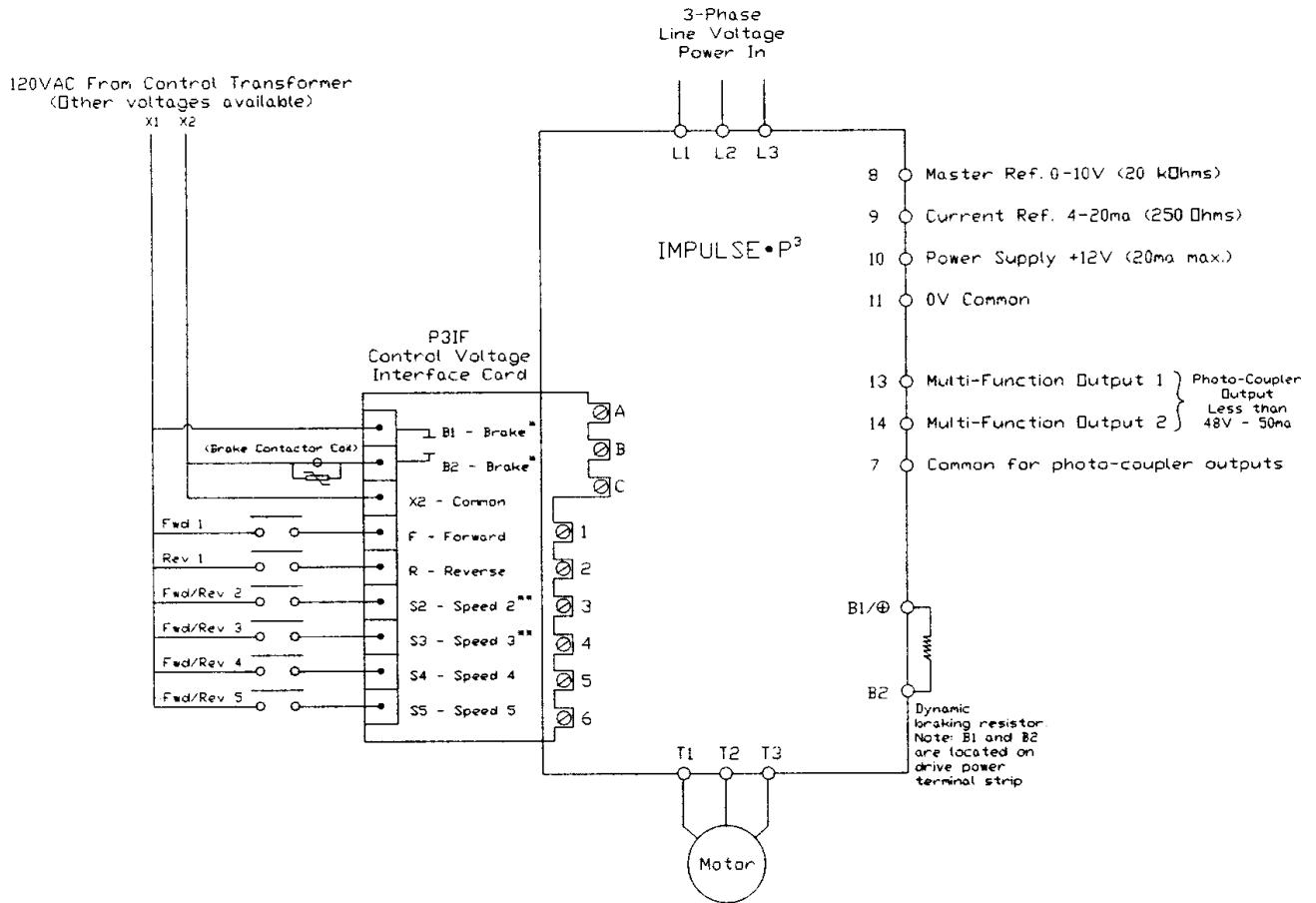

* Rating of Relay Contact is 1 Amp, \leq 250VAC. The brake will usually require an intermediate contactor.

NOTE: B1 and B2 are located on the control interface card.

** Also called “Hold Input” or “Increase Frequency Input”

See the table on the following page for drive terminal descriptions.

3.2 Control Circuit Interconnections (Continued)

Classification	Drive Terminal	Signal Name	Function		Signal Level
Sequence Input Signal	1	Forward run/stop signal	Forward run at "Closed", stop at "Open"		Photo-coupler isolated input 24VDC 8 mA
	2	Reverse run/stop signal	Reverse run at "Closed", stop at "Open"		
	3	Multi-Function Input 1	Multifunction contact inputs; 3 signals available to select		
	4	Multi-Function Input 2			
	5	Multi-Function Input 3			
	6	Sequence control input common terminal	Common terminal for sequence input		
Analog Input Signal	10	Power supply terminal for frequency setting	Speed ref. power supply		+12V (Allowable current 20mA max.)
	8	Frequency ref.	0 to +10V/max. output frequency		0 to +10V (20kW)
	9		4 to 20 mA/max. output frequency		4 to 20mA (250W)
	11	Common terminal for reference inputs	OV		—
Sequence Output Signal	13	Multi-Function Output 2	Multifunction photo-coupler outputs; two signals available to select		Photo-coupler output +48 VDC 50mA or less
	14	Multi-Function Output 3			
	7	Photo-coupler output common	Common terminal for sequence output		
	FLT-A	Multi-Function Output 1	Normally Open		Contact capacity 250VAC; 1A or less 30VDC; 1A or less
	FLT-B		Normally Closed		
	FLT-C	Fault signal contact output common	Common		
Analog Output Signal	12	Frequency meter	0 to +10 V/max. output frequency possible to select current meter output 1		0 to 11V max 2mA or less
	11	Common			

3.2.1 Wire Size

All of the control wiring used with the IMPULSE•P³ unit should be at least 16 AWG.

3.2.2 Direction and Speed Selection Input Commands

The IMPULSE•P³, when used with the interface card (P3IF), has been specifically designed to be directly compatible with 120 VAC input signals. There is no need to add interface relays or isolation circuitry. The IMPULSE•P³ control inputs are all optically isolated to provide superior immunity from electrical noise common in the industrial environment.

The control inputs for crane, hoist and monorail applications are typically provided by means of a remote operator's station or pendant control (i.e. pushbutton station). Section 3.2 shows a common control scheme utilizing a cumulative-type, two-, three-, four-, or five-step pushbutton control.

***IMPORTANT NOTE:** The number of input steps required (one-, two-, three-, four-, or five-step) depends on the number of speed steps required. Section 6 of this manual outlines the various capabilities of the IMPULSE•P³, and lists the number of input steps required to achieve that particular method of speed control. Once the speed control method is known, the actual control circuit interconnection requirements are also known. In fact, the power and flexibility of the IMPULSE•P³ allows the user to change from one speed control method to another without changing any input wires, as long as each method utilizes the same number of input steps. (See Section 6 for more details.)*

3.2.3 Motor Brake Interlock Output Command

The IMPULSE•P³, in combination with the P3IF interface card, has been specifically designed to provide an output signal that is used to energize the brake contactor coil (BC) and release the motor brake at the same time the unit receives a forward/reverse command. This output is often referred to as a run contact output. (See Section 3.2.)

***IMPORTANT NOTE:** The state of the brake interlock output signal when the IMPULSE•P³ receives a STOP command depends on the chosen method of braking. Section 6.2 of this manual outlines the two different methods of braking that are available with the IMPULSE•P³. Regardless of the braking method, the control wiring does not change. The power and flexibility of the IMPULSE•P³ allows the user to change from one braking method to another without changing any wires. (See Section 6 for more details.)*

3.2.4 Motor Thermal Overload Relay (When Used)

A normally closed contact of the thermal overload relay should be wired in series with the (X2) signal lead to stop operation in the event of a motor thermal condition. (See Section 3.2.)

- When multiple thermal overload relays are being used, the relay contacts should be wired in series with the (X2) signal lead.
- When motors with thermal detectors are used, the overload contact should be wired in series with the (X2) signal lead.
- When only a single direction is to be interrupted by a motor overload condition (such as a hoist), the overload relay contact should be placed in series with the appropriate directional input.

3.2.5 Multi-Function Output Contacts

A fault multi-function photo-coupled (PHC) output (48Vdc, 50mA or less) is provided on the main logic card circuit board. This can be used in a specific control scheme to signal an IMPULSE•P³ protective fault condition, frequency agree condition, etc. (See section 3.2 before applying this PHC output.)

NOTE: To drive an inductive load, be sure to insert a free-wheel diode to control surge voltage.

3.2.6 Additional Wiring Precautions

An R-C type (not MOV type) surge absorber must be used across the coil of all contactors and relays contained within the same electrical enclosure as the IMPULSE•P³. Failure to do so will result in noise related nuisance fault conditions (See Section 3.2.6.1 for applicable surge absorbers.)

R-C type (not MOV type) surge absorbers are sometimes required to suppress the coils of AC electro-mechanical brakes. Be certain to test all functions of the IMPULSE•P³ system if 3Ø AC brakes are applied. (See Section 3.2.6.1 for applicable surge absorbers.) Failure to adhere to this precaution may lead to nuisance noise related fault conditions.

Source kVA MUST BE limited to ≤500 to protect against premature rectifier assembly failure. If Source kVA exceeds 500, then installation of appropriate reactor is required. If multiple inverters are used, installation of individual reactors is not required. One reactor capable of combined amperage is acceptable. (See Section 3.2.6.2 for details.)

3.2.6.1 R-C Surge Absorber Specifications

Applied VAC/ General Applications	Capacitor	Resistor	Part Number*
120VAC(1Ø) for contactor coil/magnetic brake coils	0.47µF ^d **	100**	RCS1G6**
	0.47µF ^d	150	RCS1H6
	0.47µF ^d	220	RCS1A6
240VAC(1Ø) for contactor coil/magnetic brake coils	0.47µF ^d	100	RCS2G6
	0.47µF ^d	150	RCS2H6
	0.47µF ^d	220	RCS2A6
480VAC (3Ø) for 3Ø brake coils	0.47µF ^d	100	RCY6G-30
	0.47µF ^d	220	RCY6A-30

*Part numbers are those of R-K Electronics.

** Electromotive Systems standard.

3.2.6.2 AC Reactor Specifications

Model Number	Max. Cont. Amps	230V Part Number	230V Max Hp	460V Part Number	460V Max. Hp
230AFD1-P3	4	REA230-1	1	—	—
230AFD2-P3	8	REA230-2	2	—	—
230AFD3-P3	12	REA230-3	3	—	—
230AFD5-P3	18	REA230-5	5	—	—
460AFD1-P3	2	—	—	REA460-1	1
460AFD2-P3	4	—	—	REA460-2	2
460AFD3-P3	4	—	—	REA460-3	3
460AFD5-P3	8	—	—	REA460-5	5
These sizes are for combinations of multiple low capacity inverters.	25	REA230-7.5	7.5	REA460-15	15
	35	REA230-10	10	REA460-25	25
	45	REA230-15	15	REA460-30	30
	55	REA230-20	20	REA460-40	40

* Reactors are 3% impedance type

Section 4: Digital Keypad

4.1 Keypad Layout and Key Functions

The IMPULSE•P³ is a completely digital drive that can precisely control the motions of a standard three-phase induction motor to create infinitely variable speed control. Because it is completely digital, there are no potentiometers or selector switches to be adjusted. Instead, the unit is shipped with a standard digital keypad. This device is very powerful, not only allowing convenient access to the programming parameters, but also providing alpha-numeric indication of fault codes to simplify troubleshooting. This digital keypad will allow you to do the following:

- Program the various parameters (or constants).
- Read alpha-numeric fault diagnostics.
- Monitor the performance of the unit.

The digital keypad is shown below:

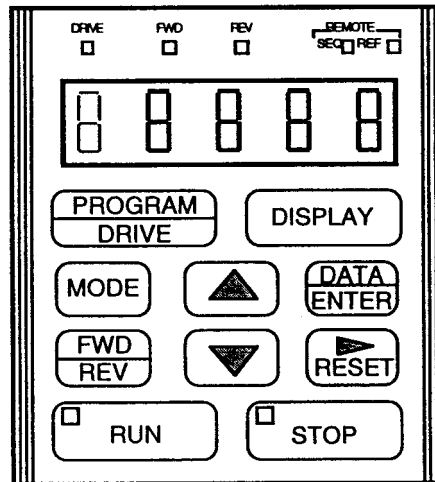

4.2 Programming Mode Key Functions

Some keys on the digital keypad have dual purposes, depending on whether the keypad is being used in the programming mode, or the local operation mode.

The various keypad functions listed below are operational when the IMPULSE•P³ is being used to program various parameters (or is in the program mode):

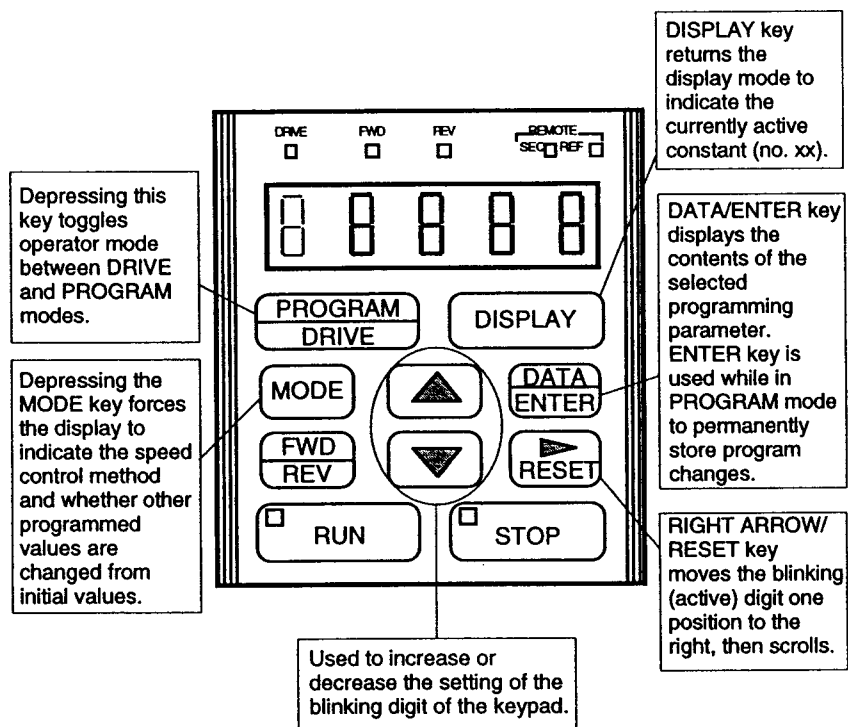

4.3 Local Operation Control Mode Key Functions

NOTE: In most cases, local operation is ONLY used for troubleshooting purposes.

The various keypad functions listed below are operational whenever the IMPULSE•P³ is in the drive mode (or ready to run the motor either locally, or remotely, via external input commands).

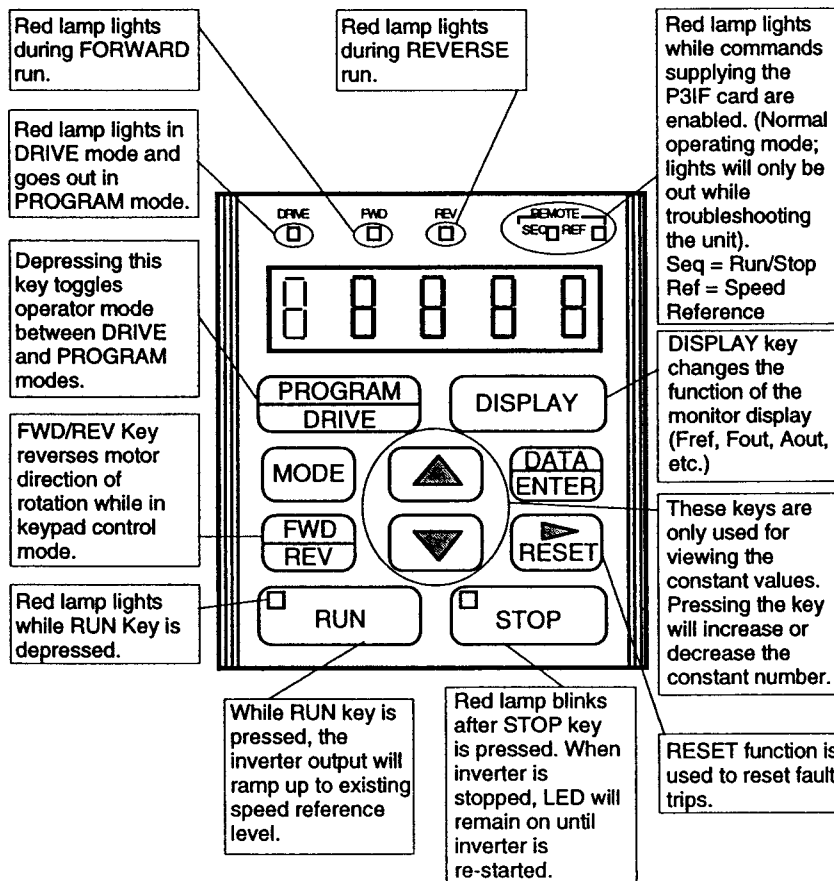



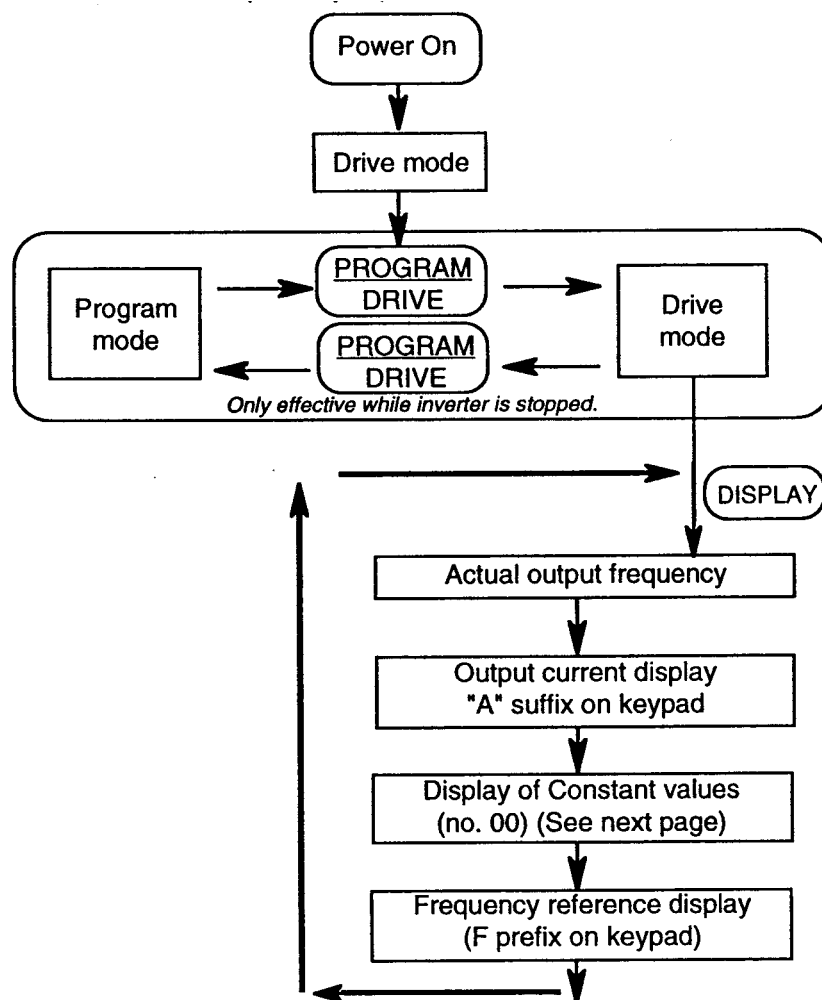

4.3 Local Operation Control Mode Key Functions (Continued)

Each time the Display key is pressed, the display mode will change:



4.3 Local Operation Control Mode Key Functions (Continued)

Reading Constant Values: Local Operation still permits the user to perform simple troubleshooting. When the DISPLAY key is pressed until the display mode becomes "no. 00", the user can view the data of constants 0 ~ 14 as below:	
Press	Display Reads
	no - 00
	05
	no - 00
	no - 01
	*
	no - 01

* Value depends upon inverter current rating.

4.4 Passive Cover Option

IMPULSE•P³ is available with a passive cover option in lieu of the digital keypad. The passive cover will indicate certain operation and fault conditions, but will not allow for any programming of the drive. A digital keypad operator must be used for programming the unit. Refer to Section 11 for fault conditions and descriptions.

The passive cover is shown below:

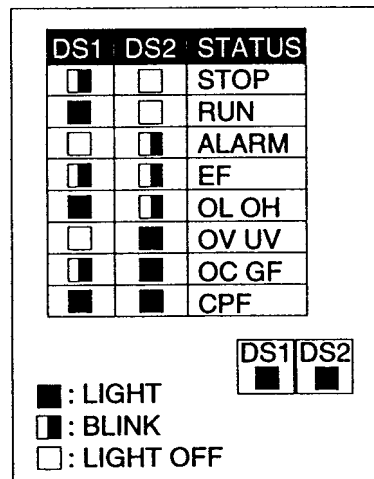

Section 4.5 outlines operation and fault conditions shown by the passive cover indicator lights.

4.5 IMPULSE•P³ Passive Cover Display and Status

Inverter Status	LED Display		Status	Recommended Action
	DS1	DS2		
Normal			Operation ready (during STOP)	—
			During normal RUN	
Alarm			Undervoltage (UV), external base block while stopped	Automatic recovery after fault is removed
Protective Operation			Inverter external fault (EF is input).	Can be reset after removing the cause of fault
			Overload protection such as inverter overload (OL), fin overheat, etc.	
			Voltage protection such as overvoltage (OV), undervoltage (UV)	
			Overcurrent protection (OC) Ground Fault (GF)	
Inverter Fault			Digital hardware memory fault (CPF)	Cannot be reset. Call Electromotive Systems, Inc.
			Hardware fault such as control power supply fault, CPU runaway, etc.	Cannot be reset. Call Electromotive Systems, Inc.

: Light : Blink : Light Off

Section 5: To Begin Programming

WARNING

A thorough understanding of adjustable frequency drive constants and expected outcomes is necessary before changing the value of any constants. Failure to conform to the above warning statement may result in unexpected operation and movement of equipment.

5.1 What is a Constant?

In this manual, the term constant simply refers to one of many operating parameters which can be adjusted and/or monitored. Each constant carries a number designation (beginning with the number “00”), and each constant is assigned a specific function or functions. IMPULSE•P³ provides the power and flexibility to tailor the inverter to virtually any crane/hoist application.

5.2 Access to the Various Constants

There are four levels of accessibility to the IMPULSE•P³ constants. The most vital constant is no-02, as it allows access to the other drive programming parameters.

Constant	Name	Digit	Data/Increment	Function	Initial Value
no-02	Password	Enables and disables reading and setting of constants			00
		—	00	Reading constants 00~14 is enabled, setting disabled (except No. 02)	
		—	01	Reading constants 00~14 is enabled, setting constants 00~02 only	
		—	02	Reading all constants (00~55) is enabled, setting constants 00~14 is enabled	
			09 or 0A	Read/Setting all constants are enabled	

5.3 X-Press Programming™– Programming the Easy Way

IMPULSE•P³ employs X-Press Programming to simplify the programming of the inverter. A coding system has been developed that allows the programmer to set just a single constant (no-00) for a variety of data that then “initializes” all other inverter constants. X-Press Programming makes it easy to set all constants of the drive without considering other constant descriptions, V/F Patterns, etc. This simple system allows most programming to be completed within seconds.

Constant 00 Data	Control Mode								
	Speed Control Mode	Braking Mode	V/F Pattern	Lower Limit (Speed 1)	Speed 2	Speed 3	Speed 4	Upper Limit (Speed 5)	
Affected Constants	Constants 32, 33, 34	Constant 13, Digit 3	Constants 47, 49	Constant 03	Constant 04	Constant 05	Constant 06	Constant 07	
00	TRAVERSE	Two-Speed Multi-Step	Braking to a STOP in time of Constant no-09	Low Torque (low V-Boost) for Traverse Applications	6.0 Hz	60.0 Hz	—	—	—
01		Three-Speed Multi-Step				30.0 Hz	60.0 Hz	—	—
02		Five-Speed Multi-Step				15.0 Hz	30.0 Hz	45.0 Hz	60.0 Hz
03		Two-Step Infinitely Variable				—	—	—	
04		Three-Step Infinitely Variable				—	—	—	
05	HOISTING	Two-Speed Multi-Step	Base Block to STOP (Immediate Stop at STOP command)	High Torque (high V-Boost) for Hoisting Applications	6.0 Hz	60.0 Hz	—	—	—
06		Three-Speed Multi-Step				30.0 Hz	60.0 Hz	—	—
07		Five-Speed Multi-Step				15.0 Hz	30.0 Hz	45.0 Hz	60.0 Hz
08		Two-Step Infinitely Variable				—	—	—	
09		Three-Step Infinitely Variable				—	—	—	

5.4 IMPULSE•P³ Constant Descriptions

Name	Constant	Digit	Data/ Increment	Function	Initial Value	Data Range
Constant no-00 initializes the inverter and allows X-Press Programming setting						
X-Press Programming	no-00	—	00	Initialize for traverse/two-speed multi-step control	05	00-0A
			01	Initialize for traverse/three-speed multi-step control		
			02	Initialize for traverse/five-speed multi-step control		
			03	Initialize for traverse/two-step infinitely variable control		
			04	Initialize for traverse/three-step infinitely variable control		
			05	Initialize for hoist/two-speed multi-step control		
			06	Initialize for hoist/three-speed multi-step control		
			07	Initialize for hoist/five-speed multi-step control		
			08	Initialize for hoist/two-step infinitely variable control		
			09	Initialize for hoist/three-step infinitely variable control		
			0A	Initialize all constants—Same as data 05		
Constant no-01 tailors the inverter characteristics to the motor nameplate data						
Motor Rated Current	no-01	—	*	To set the motor nameplate current	*	0.1~ 21.0
Constant no-02 enables and disables reading and setting of constants						
Password	no-02	—	00	Reading constants 00~14 enabled. Setting disabled (except No. 02)	00	00~02
			01	Reading constants 00~14 enabled. Setting constants 00~02 only.		
			02	Reading all constants enabled. Setting constants 00~14 enabled.		
			09 or 0A	Read/Setting all constants are enabled.		

* Value depends upon inverter current rating.

NOTE: When changing control speed method no-00 to 05 through 0A, no-47 should = 18.5, no-49 should = 12.6 for 230V or no-47 should = 39 and no-49 should = 25.2 for 460V.

Section 5

To Begin Programming

5.4 IMPULSE•P³ Constant Descriptions (Continued)

Name	Constant	Digit	Data/ Increment	Function	Initial Value	Data Range
Speed 1	no-03	—	0.1 Hz	Sets the Hz of lower limit/speed 1	6.0	1.5~ 150.0
Speed 2	no-04	—	0.1 Hz	Sets the Hz of speed 2	**	1.5~ 150.0
Speed 3	no-05	—	1 Hz	Sets the Hz of speed 3	**	2.0~ 150.0
Speed 4	no-06	—	1 Hz	Sets the Hz of speed 4	**	2.0~ 150.0
Upper Limit/ Speed 5	no-07	—	1 Hz	Sets the Hz of upper limit/speed 5/ Swift Lift threshold frequency	60	2.0~ 150.0
Acceleration Time	no-08	—	0.1 Sec.	Sets the acceleration between start and no-43	5.0	0.0~ 25.5
Deceleration Time	no-09	—	0.1 Sec.	Sets the deceleration between no-43 and 0.0 Hz	3.0	0.0~ 25.5
Constant no-10 enables and disables special functions of the inverter						
Special Functions	no-10	1	0	Quick Stop disabled	0000	0000~ 0111
			1	Quick Stop enabled		
		2	0	Reverse Plug Simulation disabled		
			1	Reverse Plug Simulation enabled		
		3	0	Swift Lift disabled		
			1	Swift Lift enabled***		
		4	0	No function		
			1			
Acceleration Time 2	no-11	—	0.1 sec	Sets the alternate (Reverse Plug Simulation) acceleration time	2.5se- c	0.0~ 25.5
Deceleration Time 2	no-12	—	0.1 sec	Sets the alternate (Quick Stop/Reverse Plug Simulation) deceleration time	1.5se- c	

* Digits read right to left. 0000

| |
 4th Digit 1st Digit

** Initial value set by X-Press Programming—constant 00.

*** Swift-Lift should not be used with two-step or three-step infinitely variable control.

5.4 IMPULSE•P³ Constant Descriptions (Continued)

Name	Constant	Digit	Data/ Function	Function	Initial Value	Data Range
Constant no-13 sets local/remote reference; START/STOP; and sets the braking mode						
Run Signal Selection 1	no-13	1	0	Master reference is analog main channel only	Changed by constant 00	0000~ 1111
			1	Master reference is per digital keypad (internal)		
		2	0	Run by external terminal		
			1	Run by digital keypad**		
		3	0	Deceleration to STOP		
			1	Base Block to STOP		
		4	0	Voltage compensation enabled		
			1	Voltage compensation disabled		
Constant no-14 enabled and characterizes the inverter's thermal simulation						
Motor Protection Selection	no-14	1	0	Electronic thermal simulation enabled	0100	0000~ 1111
			1	Electronic thermal simulation disabled		
		2	0	Standard motor simulation		
			1	Inverter motor simulation		
		3	0	Thermal time constant is for continuous motor		
			1	Thermal time constant is for short time rated motor		
		4	0	Fault is reset after RUN command is removed		
			1	Fault is not reset automatically		
Auto Reset Limit	no-15	—	1	Fault reset attempt before latch	10	010 0=∞

* Digits read right to left. 0000

| |
 4th Digit 1st Digit

** While running from the keypad (no-13, digit 2 = 1), the drive will run at the frequency set in constant no-04. It will also always base block to stop, regardless of the setting of no-13, digit 3.

5.4 IMPULSE•P³ Constant Descriptions (Continued)

Name	Constant	Digit	Data/Increment	Function	Initial Value	Data Range
Selection of Other Functions	no-16	1	0	Stall prevention during decel provided	1001	0000~1111
			1	Stall prevention during decel not provided		
		2	0	Analog output = frequency output		
			1	Analog output = current output		
		4, 3	00	S-curve not provided		
			10	S-curve is 0.2 seconds		
			01	S-curve is 0.5 seconds		
			11	S-curve is 1.0 seconds		
Constant no-17 enabled and characterizes the overtorque function						
Overtorque Detection Selection	no-17	1	0	Overtorque detection is not provided	0000	0000~1111
			1	Overtorque detection is provided		
		2	0	Detected only during constant running		
			1	Detected under all conditions		
		3	0	Operation continues after overtorque detection		
			1	Base block at overtorque detection		
		4	0	No function		
			1			
Overtorque Detect Level	no-18	—	1%	Overtorque level set in % of inverter rated current	100%	10~150%
Overtorque Detect Time	no-19	—	0.1 Sec.	Overtorque time is set by 0.1 second	0.2 Sec.	0.0~1.2

* Digits read right to left. 0000
 | |
 4th Digit 1st Digit

5.4 IMPULSE•P³ Constant Descriptions (Continued)

Name	Constant	Digit	Data/ Increment	Function	Initial Value	Data Range
Swift Lift Frequency	no-20	—	1 Hz	The maximum frequency output during Swift Lift	60 Hz	2~150
Swift Lift Current at Forward	no-21	—	1%	Judging current at forward operation	50%	10~100%
Swift Lift Current at Reverse	no-22	—	1%	Judging current at reverse operation	0%	10~100%
Swift Lift Judging Time	no-23	—	0.1 Sec.	Judging time is set in 0.1 second increments	0.2 Sec	0.1~25.5
Analog Gain	no-24	—	0.01	Gain of the analog reference is set	1.00	0~2.55
Analog Bias	no-25	—	0.01	Bias of the analog reference is set	0.00	± 1.00
DC Injection Current	no-26	—	1%	DC injection current is set in 1% of inverter rated current	50%	0~100
DC Injection Time at STOP	no-27	—	0.1 Sec.	DC injection time is set in 0.1 second increments	0.5 Sec	0.0~1.2
DC Injection Decay Time	no-28	—	0.1 Sec.	Special function for conical rotor motor	0.0 Sec	0.0~1.2
Auto Torque Gain	no-29	—	0.1	Automatic torque compensation gain	1.0	0.0~3.0
Stall Prevention During Accel	no-30	—	1%	Stall prevention during acceleration	170%	30~200%
Stall Prevention During Running	no-31	—	1%	Stall prevention during constant running	160%	30~200%

5.4 IMPULSE•P³ Constant Descriptions (Continued)

NOTE: Multi-function inputs are set to default values based on speed control method. Some speed control methods require specific programming of inputs and will not allow the constants to be reprogrammed.

Name	Constant	Digit	Data/ Increment	Function	Initial Value	Data Range
Constant no-32 selects the function of terminal 3 (cannot be changed if fixed by constant 00)						
Multi-function Input 1 Terminal 3 Function Select or P3IF Terminal S2	no-32	—	0	Multi-speed 1	Initialized by constant 00	0~1F
			3	Hold function (second step of three-step infinitely variable)		
			4	Increase function		
Constant no-33 selects the function of terminal 4 (cannot be changed if fixed by constant 00)						
Multi-Function Input 2 (Terminal 4 Function Select) or P3IF Terminal S3	no-33	—	1	Multi-speed 2	Initialized by constant 00	0~1F
			4	Increase function		
			5	Swift Lift enable command*		
			6	Fault reset		
			7	Accel/decel time selection (no-11, no-12)		
			8	External base block at closed		
			9	External base block at open		
			A	DC injection command		
			10-1F	External Fault Input		

* Swift-Lift should not be used with two-step or three-step infinitely variable control.

5.4 IMPULSE•P³ Constant Descriptions (Continued)

Name	Constant	Digit	Data/ Increment	Function	Initial Value	Data Range
Constant no-34 selects the function of terminal 5 (cannot be changed if fixed by constant 00)						
Multi-function Input 3 (Terminal 5) Function Select or P3IF Terminal S5	no-34	—	2	Multi-speed 3	Initializ- ed by constant 00	0~1F
			5	Swift Lift enable command*		
			6	Fault reset		
			7	Accel/decel time selection (no-11, no-12)		
			8	External base block at closed		
			9	External base block at open		
			A	DC injection command		
			10~1F	External fault input (n/o)		
Constant no-35 selects the function of terminals B1 and B2						
Multi-Function Output 1 Output Relay Function Select	no-35	—	0	Closed at inverter running	00	0~5
			1	Closed at zero speed		
			2	Closed when F-Out \geq constant 38 (Hys.=1%)		
			3	Closed when F-Out \leq constant 38 (Hys.=1%)		
			4	Closed during overtorque detection		
			5	Closed at and during fault		
Constant no-36 selects the function of terminals 7 and 13 (PHC open collector output)						
Multi-Function Output 2 Open Collector Function Select	no-36	—	0	Closed at inverter running	04	0~5
			1	Closed at zero speed		
			2	Closed when F-Out \geq constant 38 (Hys.=1%)		
			3	Closed when F-Out \leq constant 38 (Hys.=1%)		
			4	Closed during overtorque detection		
			5	Closed at and during fault		

* Swift-Lift should not be used with two-step or three-step infinitely variable control.

5.4 IMPULSE•P³ Constant Descriptions (Continued)

Name	Constant	Digit	Data/ Increment	Function	Initial Value	Data Range
Constant no-37 selects the function of terminals 7 and 14 (PHC open collector output)						
Multi-Function Output 3 Open Collector Function Select	no-37	—	0	Closed at inverter running	05	0~5
			1	Closed at zero speed		
			2	Closed when F-Out ≥ constant 38 (Hys.=1%)		
			3	Closed when F-Out ≤ constant 38 (Hys.=1%)		
			4	Closed during overtorque detection		
			5	Closed at and during fault		
Frequency Detection	no-38	—	0.1 Hz	The reference frequency for constant 35/36/37, data 2/3	0.0 Hz	0.0~ 150.0 Hz
Carrier Frequency	no-39	—	2.5kHz	Sets the switching frequency of the power device	04	1~6 (2.5 to 15KHZ)
Analog Monitor Gain	no-40	—	0.01	Scales the value of the analog output	1.00	0.01~ 2.00
Fault Record	no-41	—	—	Displays the last fault	—	—
Software Number	no-42	—	—	Displays the internal software number	ESP3	—
Ramp Set Frequency	no-43	—	0.1 Hz	Upper frequency used to determine accel/decel ramps from 0 Hz.	60.0 Hz	50.0~ 150.0 Hz
Maximum Voltage	no-44	—	0.1 V	Sets the maximum output voltage of the inverter	230V 460V	0.1~255 0.1~510
Max. Volt Frequency	no-45	—	0.1 Hz	Frequency of maximum voltage	60.0 Hz	0.2~150
Intermediate Output Volts	no-47	—	0.1 V	Sets the intermediate output voltage of the inverter	Set by constant 00	0.1~255 0.2~510
Minimum Output Freq.	no-48	—	0.1 Hz	Sets the minimum output frequency of the inverter	1.5 Hz	0.1~10.0
Minimum Output Volts	no-49	—	0.1 V	Sets the minimum output voltage of the inverter	Set by constant 00	0.1~50.0 0.1~100.0

5.4 IMPULSE•P³ Constant Descriptions (Continued)

Name	Constant	Digit*	Data/ Increment	Function	Initial Value	Data Range				
Constant no-50 enables and disables functions for tests before shipping										
Factory Test Selection	no-50	1	0	Electronic thermal overload protection provided	0000	0000~0111				
			1	Electronic thermal overload protection not provided						
		2	0	Simplified AVR provided						
			1	Simplified AVR not provided						
		3	0	Power factor angle time is 20mS						
			1	Power factor angle time is constant 52						
		4	0	No function						
			1							
		Hunting Prev. Gain	no-51	—			0.01	Scales the value of the analog output	0.1	0.00~2.00
		Power Factor Time Constant	no-52	—			1	Power factor time constant	64	0~400
On Delay Offset Value	no-53	—	1	On delay offset value	12	0~24				
KVA Select	no-54	—	—	Do not change	—	—				
DC Current Transformer Gain	no-55	—	—	Do not change	—	—				

* Digits read right to left. 0000

| |
 4th Digit 1st Digit

5.5 Enabling Program Mode

Whenever an IMPULSE•P³ is initially powered up, the programming features of the unit are disabled. This is done to eliminate the possibility of someone inadvertently changing any of the programming constants. If you need to change any parameters, you first need to change the data stored in constant no-02. The step-by-step procedure is given below.



Display reads no-00



Display reads no-01



Display reads no-02

*Initial setting constant no-02=00
To enable the option of modifying the programming, you must set constant no-02 to "01", "02", "09" or "0A".



Display reads 0 0
Left digit blinking.



Display reads 0 0
Blinking digit was moved one location to the right.



Display reads 0 1
Blinking digit was changed from 0 to 1.



Display momentarily reads END,
then returns to 0 1



Display reads 0.0

You may now make any necessary program changes to the constants. **Remember, each time you remove the power from the unit, the auto-lockout feature will again reset constant no-02=00, prohibiting further changes. This means the above procedure must be repeated for additional changes at the next power-up.**

5.5.1 How to Change the Minimum Operating Speed (Constant no-03)

To change the minimum operating speed you need to change the value of constant no-03. Regardless of the speed setting method you have selected (see Section 6), constant no-03 will serve as speed setting 1 and minimum speed.

Below is an example in which you want to set the minimum speed to 9Hz. Initial value is 10% of 60Hz, or 6Hz. As a result, we must change the setting of constant no-03 from the initial setting of “006.00” to “009.00”

After enabling program mode via constant no-02:



Display reads constant most recently adjusted



Press up or down arrow keys until display reads no-03



Display reads 0 0 6 . 0
Left digit blinking.



Press until display reads 0 0 6 . 0
Blinking digit moved over two locations to the right.



Until display reads 0 0 9 . 0
Blinking digit was changed from 6 to 9.



Display temporarily reads END
then returns to 0 0 9 . 0



Display reads 0 . 0

5.5.2 How to Change Accel/Decel Time (Constant no-08/Constant no-09)

To change the accel/decel ramp, you must change constant no-08/ constant no-09. Assume the setting is 10 seconds. This is defined as the time it takes the output to go from zero speed to maximum speed/maximum speed to zero speed. As an example, lets assume you would like to increase the accel time from 10 seconds to 15 seconds. Follow the step-by-step procedure listed below:

After enabling program mode via constant no-02:



Display reads constant most recently adjusted



Press up or down arrow keys until display reads no-08



Display reads 1 0 . 0
Left digit blinking.



Press until display reads 1 0 . 0
Blinking digit moved over one location to the right.



Until display reads 1 5 . 0
Blinking digit was changed from 0 to 5.



Display momentarily reads END,
then returns to 1 5 . 0



Display reads 0 . 0

Section 6: Control Flexibility

IMPULSE•P³ is a unique combination of hardware and software that provides the user with flexibility for selection of specific crane and hoist operation modes. These modes are easily accessed by X-Press Programming and includes these functions:

Basic Application

- Traverse Application (Bridge/Trolley)
- Hoisting Application

By X-Press Method

Constant no-00 = 00 ~ 04
Constant no-00 = 05 ~ 09

Speed control method selection:

- Two-speed multi-step mode.
- Three-speed multi-step mode.
- Five-speed multi-step mode.
- Two-step infinitely variable mode.
- Three-step infinitely variable mode.
- Analog 0-10V, 4-20mA.

Constant no-00 = 00 or 05
Constant no-00 = 01 or 06
Constant no-00 = 02 or 07
Constant no-00 = 03 or 08
Constant no-00 = 04 or 09
Constant no-00 = 00 or 05
01 or 06
02 or 07
Constant no-13, digit 1 = 0

Stopping method selection:

- Immediate stop at STOP command.
- Decelerate at STOP command.

Constant no-00 = 05 ~ 09
Constant no-00 = 00 ~ 04

6.1 Speed Control Method Definitions (X-Press by Constant no-00)

IMPULSE•P³ allows the user to choose between two-, three-, four- or five-speed operation. The number of speeds depends on the number of input signals. Each input signal is assigned a frequency (speed) reference from the constants no-03 ~ 07 group as described in the following sections.

In the following chart, X = 120 VAC input to terminals of the P3IF; O = 0 VAC input to terminals of the P3IF; – = not applicable.

Terminals X2-F (R)	Terminals X2 ~ 2	Terminals X2~3	Terminals X2~4	Terminals X2~5	Output Freq. (Speed) Ref.
O	—	—	—	—	STOP*
X	O	O	O	O	Constant no-03
X	X	O	O	O	Constant no-04
X	X	X	O	O	Constant no-05
X	X	X	X	O	Constant no-06
X	X	X	X	X	Constant no-07
Terminals used for two-to five-step control		Terminals used for three-to five-step control	Terminals used for four- and five-step control	Terminals used for five-step control	

* Default stopping method is **immediate stop**. Extreme caution should be used when changing to deceleration at STOP command. A long deceleration time will cause driven equipment to require a greater stopping distance.

6.1.1 Two-Speed Multi-Step Speed Control Method (X-Press by Constant no-00 = 00 or 05)

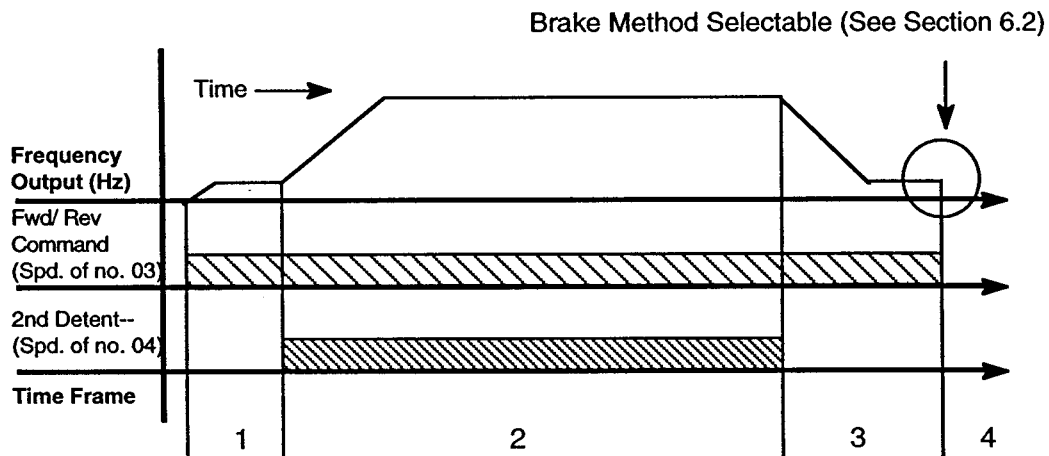

Time Frame Descriptions (no-00=05)

Time 1 Run Forward/Reverse Command. Frequency output increases to Hz of constant no-03. Operation continues at speed of constant no-03.

2 Second Detent/2nd Speed command. Frequency output increases to Hz of constant no-04. Operation continues at speed of constant no-04.

3 Removal of Second Detent/2nd Speed Command. Frequency output decreases to Hz of constant no-03. Operation continues at speed of constant no-03.

4 Absence of Commands. Removal of RUN Forward/Reverse. STOP. Operation depends on the setting of constant no-13, digit 3 which is changed by setting of no-00.

6.1.2 Three-Speed Multi-Step Speed Control Method (X-Press by Constant no-00 = 01 or 06)

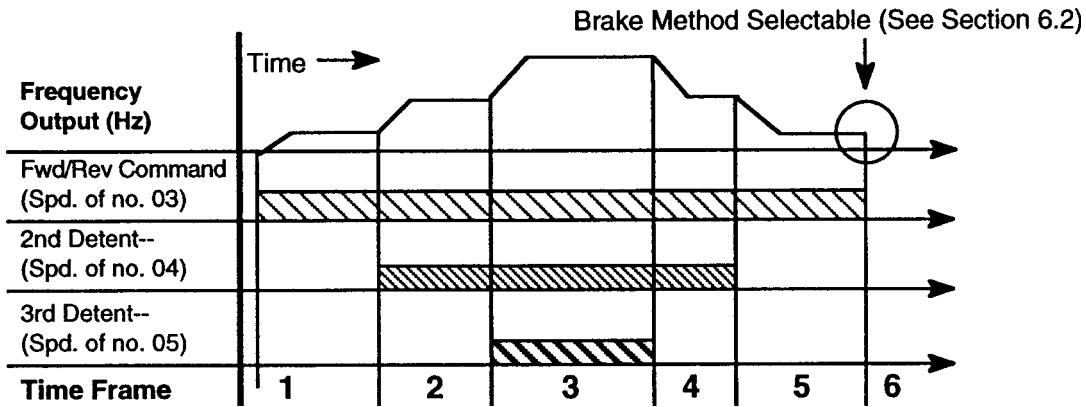

Time Frame Descriptions (no-00 = 06)

Time1 Run Forward/Reverse Command. Frequency output increases to Hz of constant no-03. Operation continues at speed of constant no-03.

2 Second Detent/2nd Speed command. Frequency output increases to Hz of constant no-04. Operation continues at speed of constant no-04.

3 Third Detent/3rd Speed Command. Frequency output increases to Hz of constant no-05. Operation continues at speed of constant no-05.

4 Removal of Third Detent/3rd Speed Command. Frequency output decreases to Hz of constant no-04. Operation continues at speed of constant no-04.

5 Removal of Second Detent/2nd Speed Command. Frequency output decreases to Hz of constant no-03. Operation continues at speed of constant no-03.

6 Absence of Commands. Removal of RUN Forward/Reverse. STOP. Operation depends on the setting of constant no-13, digit 3 which is changed by the setting of no-00.

6.1.3 Five-Speed Multi-Step Speed Control Method (X-Press by Constant no-00 = 02 or 07)

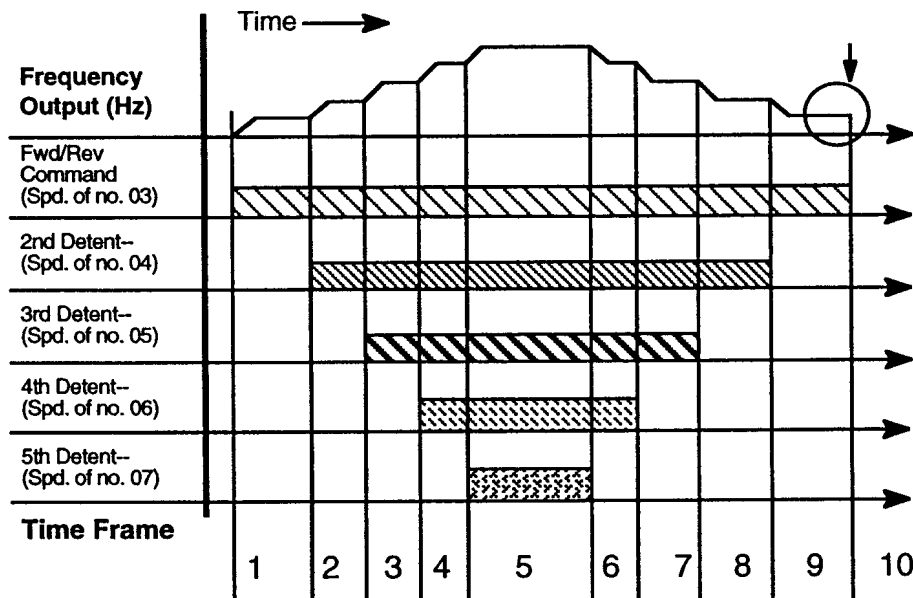

Time Frame Descriptions (no-00 = 07)

Time 1 Run Forward/Reverse Command. Frequency output increases to Hz of constant no-03. Operation continues at speed of constant no-03.

2 Second Detent/2nd Speed Command. Frequency output increases to Hz of constant no-04. Operation continues at speed of constant no-04.

3 Third Detent/3rd Speed Command. Frequency output increases to Hz of constant no-05. Operation continues at speed of constant no-05.

4 Fourth Detent/4th Speed Command. Frequency output increases to Hz of constant no-06. Operation continues at speed of constant no-06.

5 Fifth Detent/5th Speed Command. Frequency output increases to Hz of constant no-07. Operation continues at speed of constant no-07.

6 Removal of Fifth Detent/5th Speed Command. Frequency output decreases to Hz of constant no-06. Operation continues at speed of constant no-06.

7 Removal of Fourth Detent/4th Speed Command. Frequency output decreases to Hz of constant no-05. Operation continues at speed of constant no-05.

6.1.3 Five-Speed Multi-Step Speed Control Method (Continued) **(X-Press by Constant no-00 = 02 or 07)**

8 Removal of Third Detent/3rd Speed Command. Frequency output decreases to Hz of constant no-04. Operation continues at speed of constant no-04.

9 Removal of Second Detent/2nd Speed Command. Frequency output decreases to Hz of constant no-03. Operation continues at speed of constant no-03.

10 Absence of Commands. Removal of RUN Forward/Reverse. STOP. Operation depends on the setting of constant no-13, digit 3 which is changed by the setting of no-00.

6.1.4 Two-Step Infinitely Variable Speed Control (X-Press by Constant no-00 = 03 or 08)

IMPULSE•P³ provides for true infinitely variable speed control with just two simple 120 VAC inputs. This unique software function allows the use of two-speed pushbuttons.

Two-step infinitely variable is most often used on horizontal travel motions. Two-step infinitely variable speed control is described by the following timing chart:

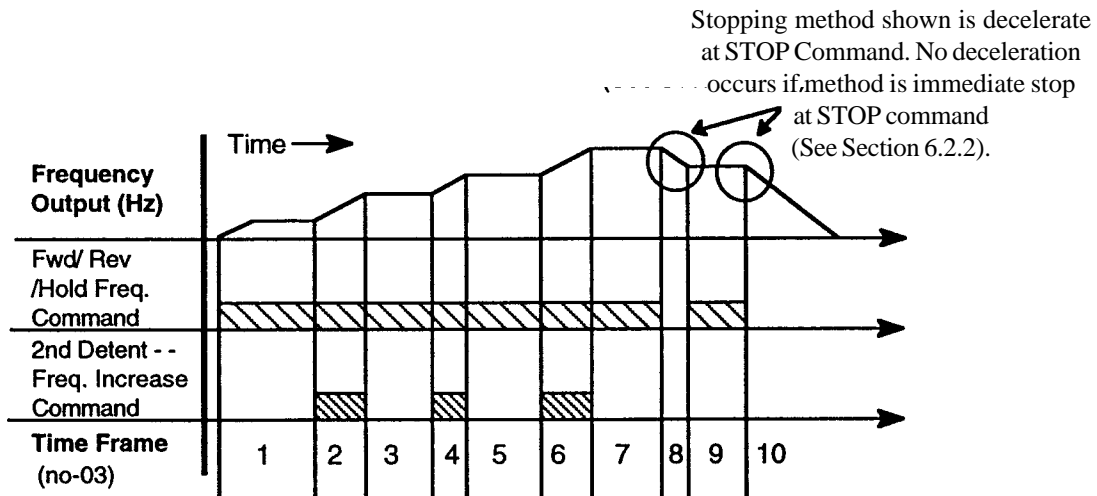

Time 1 Run Forward (Reverse) at Frequency of Hold Frequency Command. Frequency output increases to frequency of constant no-03. Operation continues at speed of constant no-03.

2 Second Detent/Frequency Increase Command. Frequency output increases. The longer this contact is closed, the higher the frequency output becomes. Limited only by the adjustable upper limit (constant no-07).

3 First Detent/Frequency Hold Command. Frequency output remains constant.

4 Second Detent/Frequency Increase Command. Frequency output increases. The longer this contact is closed, the higher the frequency output becomes. Limited only by the adjustable upper limit (constant no-07).

5 First Detent/Frequency Hold Command. Frequency output remains constant.

6 Second Detent/Frequency Increase Command. Frequency output increases. The longer this contact is closed, the higher the frequency output becomes. Limited only by the adjustable upper limit (constant no-07).

7 First Detent/Frequency Hold Command. Frequency output remains constant.

6.1.4 Two-Step Infinitely Variable Speed Control (Continued) (X-Press by constant no-00 = 03 or 08)

8 Absence of Commands = STOP Command. Output frequency decreases. The longer this input signal condition exists, the lower the output frequency becomes. Output frequency will go to zero, and the brake will set. Braking method shown is decelerate at STOP command only! (Constant no-13, digit 3 data which is changed by the setting of no-00).

9 First Detent/Frequency Hold Command. Frequency output remains constant.

10 Absence of Commands = STOP Command. Output frequency decreases. The longer this input signal condition exists, the lower the output frequency becomes. Output frequency will go to zero, and the brake will set. Braking method shown is decelerate at STOP command only! (Constant no-13, Digit 3 data which is changed by the setting of no-00).

6.1.5 Infinitely Variable Speed Control Method (Three-Step Type) (X-Press by Constant no-00 = 04 or 09)

IMPULSE•P³ provides true infinitely variable speed control with three simple 120 VAC inputs.

Three-step infinitely variable speed control is most often used on hoist motions where it is not acceptable to decelerate the motor when a STOP command is applied. (The control device is returned to the off position.) Three-step infinitely variable speed control is described below.

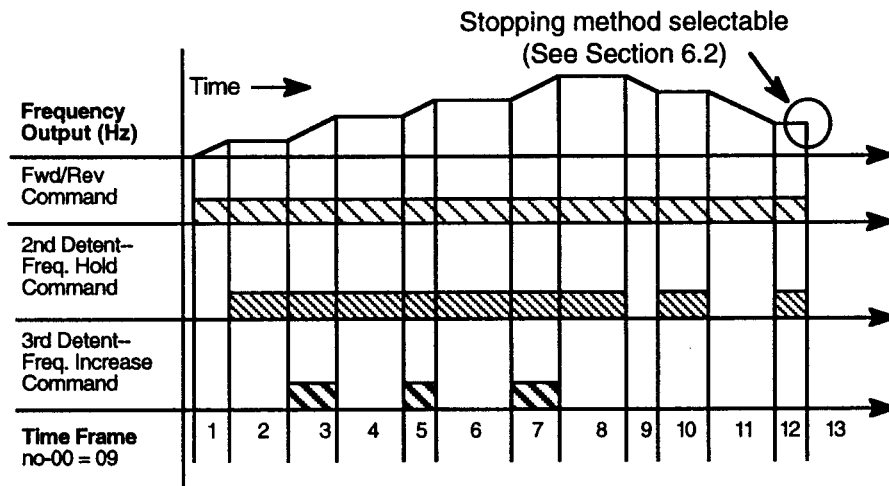

Time 1 Run Forward/Reverse Command. Frequency output increases to Hz of constant no-03. Operation continues at speed of constant no-03.

2 Second Detent/Frequency Hold Command. Frequency output remains constant.

3 Third Detent/Frequency Increase Command. Frequency output increases. The longer this contact is closed, the higher the output frequency becomes. Limited only by the adjustable upper limit (constant no-07).

4 Second Detent/Frequency Hold Command. Frequency output remains constant.

5 Second Detent/Frequency Increase Command. Frequency output increases. The longer this contact is closed, the higher the frequency output becomes. Limited only by the adjustable upper limit (constant no-07).

6 Second Detent/Frequency Hold Command. Frequency output remains constant.

6.1.5 Infinitely Variable Speed Control Method (Three-Step Type) (Continued) (X-Press by Constant no-00 = 04 or 09)

7 Third Detent/Frequency Increase Command. Frequency output increases. The longer this contact is closed, the higher the frequency output becomes. Limited only by the adjustable upper limit (constant no-07).

8 Second Detent/Frequency Hold Command. Frequency output remains constant.

9 Run Forward/Reverse at Lower Limit Command. Frequency output decreases. The longer this input signal condition exists, the lower the output frequency becomes. Limited only by constant no-03.

10 Second Detent/Frequency Hold Command. Frequency output remains constant.

11 Run Forward/Reverse Command. Frequency output decreases. The longer this input signal condition exists, the lower the output frequency becomes. Limited only by constant no-03.

12 Second Detent/Frequency Hold Command. Frequency output remains constant.

13 Absence of Command = STOP Command. Output frequency decreases. The longer this input signal condition exists, the lower the output frequency becomes. Output frequency will go to zero, and the brake will set. Braking method shown is decelerate at STOP command only! (constant no-13, digit 3 data which is changed by the setting of no-00).

6.2 Stopping Method Definitions (Constant no-13, Digit 3 which is changed by setting of no-00)

IMPULSE•P³ provides for both types of commonly accepted braking methods:

- Immediate stop at STOP command
(constant no-13, digit 3 = data 1)
- Decelerate at STOP command
(constant no-13, digit 3 = data 0)

Default stopping method is **immediate stop**. Extreme caution should be used when changing to deceleration at STOP command. Operation should not begin until the user has reviewed the deceleration time found in constant no-09. A long deceleration time will cause driven equipment to require a greater stopping distance.

6.2.1 Immediate Stop at STOP Command

Upon STOP command, IMPULSE•P³ base blocks main output transistors (i.e. the motor is electrically disconnected from the drive). The brake interlock relay (terminals B1 ~ B2) sets the motor brake. See below for operation characteristics.

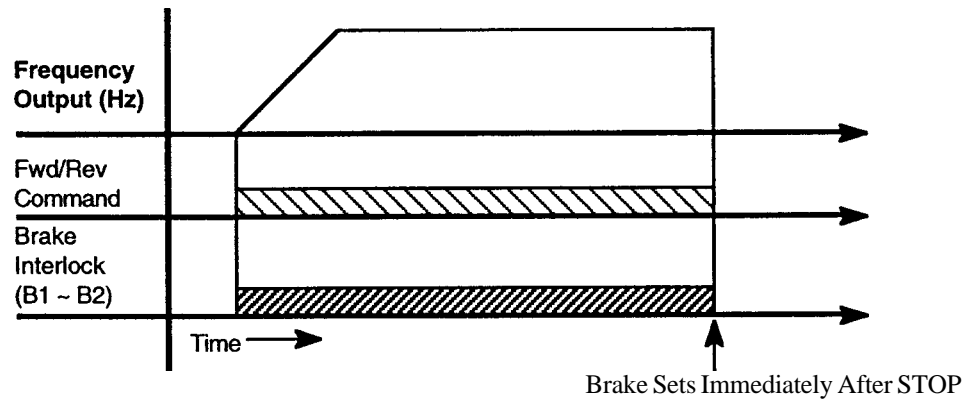

6.2.2 Decelerate at STOP Command

Upon STOP command, IMPULSE•P³ output frequency decreases to near zero, DC injects for a few milliseconds, then the brake interlock relay (terminals B1~B2) sets the motor brake. See below for operation characteristics.

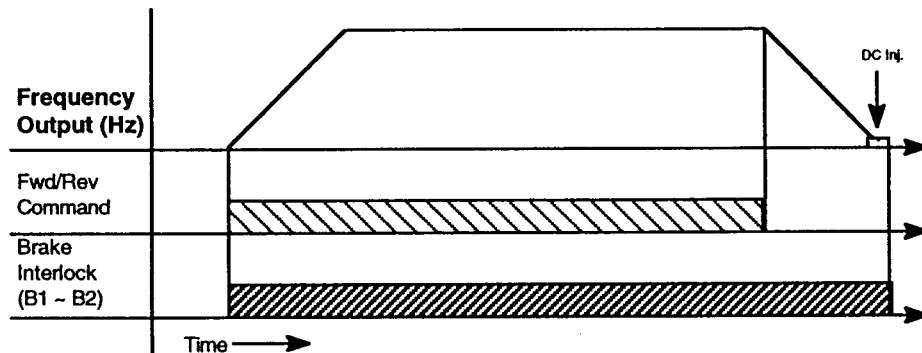

Section 7: Setting Recipes

7.1 Two Speed Multi-Step Control Method (X-Press Constant no-00 or 05)

Specific settings and control circuit connections are required to begin two-speed multi-step control operation. The recipe requires both control circuit connections and specific programming changes via the digital keypad.

7.1.1 Control Circuit Wiring Diagram for Two-Speed Multi-Step Control

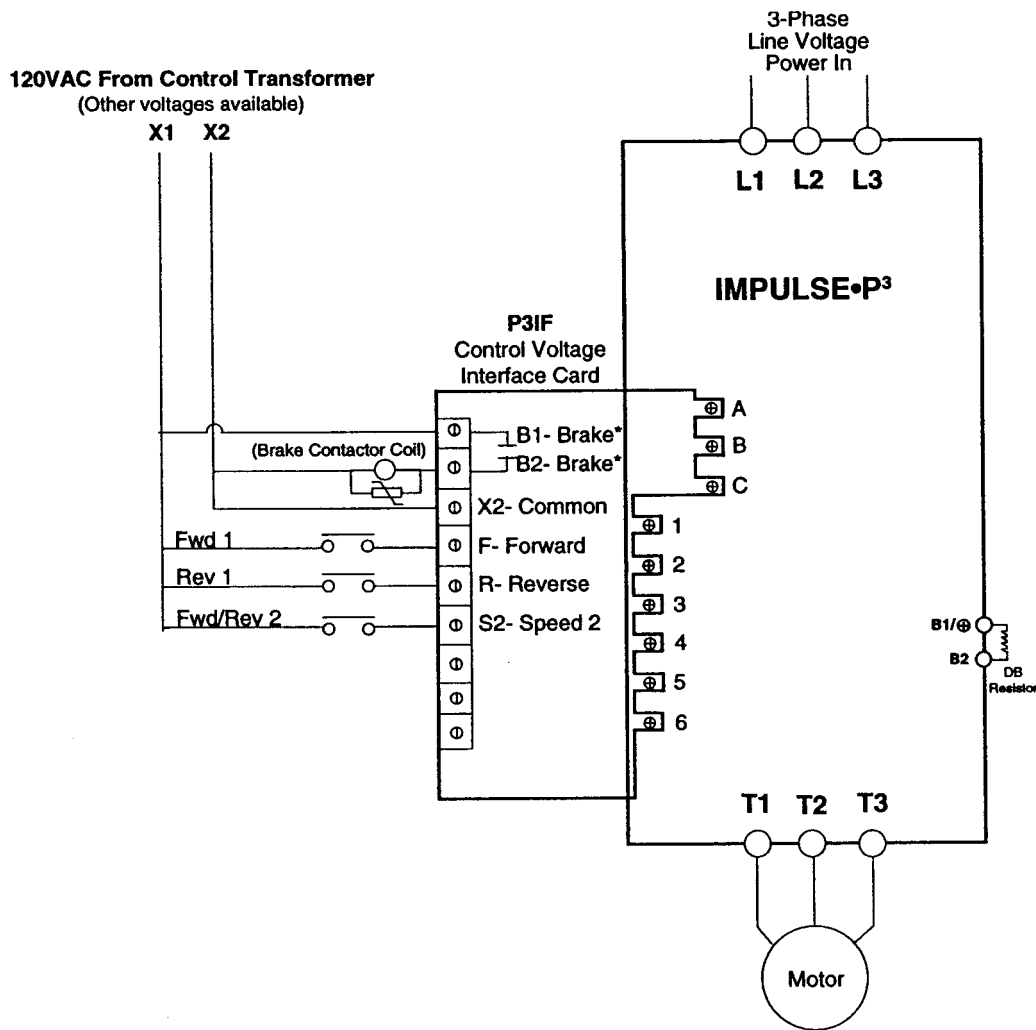

*Note: Brake contact rated for 250 VAC, ≤ 1 Amp

7.1.2 Control Circuit Input Sequence for Multi-Step Speed Control

In the following chart, X = 120 VAC input to terminals of P3IF; O = 0 VAC input to terminals of P3IF; - = not applicable.

Terminals X2~F (R)	Terminals X2~2	Action
O	—	STOP*
X	O	Runs at Hz of Constant no-03
X	X	Runs at Hz of Constant no-04
Terminals used for two-to five-step control		

* Default stopping method is **immediate stop**. Extreme caution should be used when changing to deceleration at STOP command. A long deceleration time will cause driven equipment to require a greater stopping distance.

7.1.3 X-Press Settings for Other Constants (Two-Speed Multi-Step Control)

IMPORTANT:

- The X-Press values were established from our experience in the crane and hoist industry. These values have been proven typical for the crane and hoist builder. Actual setting values should be determined by the specific application. (See Section 5 for more information.)
- Only those values typically changed from Electromotive Systems' initial values are indicated in the table below. Please read and understand Section 5 completely before proceeding with programming. There may be constants and functions not listed below that will increase the application precision of IMPULSE•P³.
- Electromotive Systems' software includes powerful and useful functions for crane and hoist applications. Be sure to completely read Section 8 to apply these features and functions.

7.1.3 X-Press Settings for Other Constants (Two-Speed Multi-Step Control) (Continued)

X-Press Initial Values for Two-Speed Multi-Step Control Mode					
Constant	Description	Bridge/Trolley X-Press Data =00		Hoist X-Press Data = 05	
no-02	Enables changing of constants	Must be data 02			
no-01	Motor rated current	Motor Nameplate Amps			
no-03	Multi-Step speed 1/Minimum speed	6.0 Hz			
no-04	Multi-step speed 2	60.0 Hz			
no-08	Acceleration time	5.0 Seconds			
no-09	Deceleration time	3.0 Seconds			
no-13, D3	Stopping method selection*	0		1	
		230 Volts	460 Volts	230 Volts	460 Volts
no-47	V/F Pattern Selection Setting	16.1	32.2	24.1	48.2
no-49	V/F Pattern Selection Setting	9.2	18.4	17.2	34.4
no-44	Input Voltage (actual)	230/460			

* Default stopping method is **immediate stop**. Extreme caution should be used when changing to deceleration at STOP command. A long deceleration time will cause driven equipment to require a greater stopping distance.

**7.2 Three-Speed Multi-Step Control Method
(X-Press Constant no-00 = 01 or 06)**

Specific settings and control circuit connections are required to begin three-speed multi-step control operation. The recipe requires both control circuit connections and specific programming changes via the digital keypad.

7.2.1 Control Circuit Wiring Diagram for Three-Speed Multi-Step Control

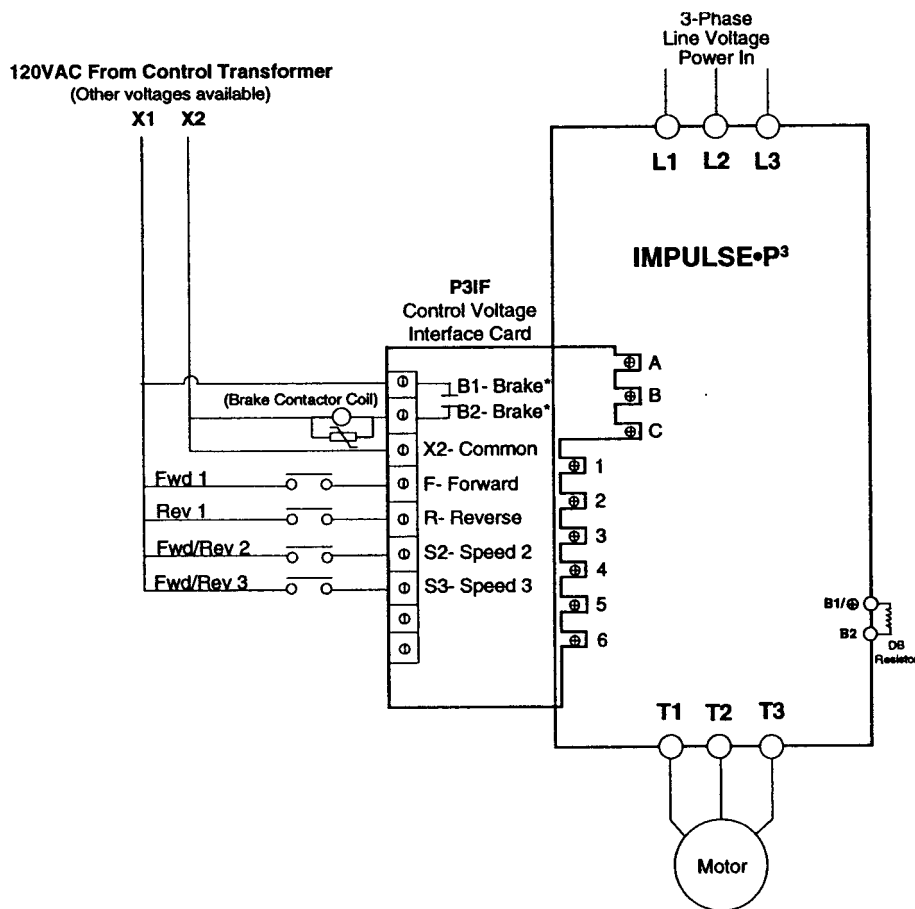

*Note: Brake contact rated for 250 VAC, ≤ 1 Amp

7.2.2 Input/Output Reference for Three-Speed Multi-Step Control

In the following chart, X = 120 VAC input to terminals of P3IF; O = 0 VAC input to terminals of P3IF;
 — = not applicable.

Terminals X2~F (R)	Terminals X2~2	Terminals X2~3	Action
O	—	—	STOP*
X	O	O	Runs at Hz of Constant no-03
X	X	O	Runs at Hz of Constant no-04
X	X	X	Runs at Hz of Constant no-05
Terminals used for two-to five-step control			

* Default stopping method is **immediate stop**. Extreme caution should be used when changing to deceleration at STOP command. A long deceleration time will cause driven equipment to require a greater stopping distance.

7.2.3 X-Press Settings for Other Constants (Three-Speed Multi-Step Control)

IMPORTANT:

- The X-Press values were established from our experience in the crane and hoist industry. These values have been proven typical for the crane and hoist builder. Actual setting values should be determined by the specific application. (See Section 5 for more information.)
- Only those values typically changed from Electromotive Systems' initial values are indicated in the table below. Please read and understand Section 5 completely before proceeding with programming. There may be constants and functions not listed below that will increase the application precision of IMPULSE•P³.
- Electromotive Systems' software includes powerful and useful functions for crane and hoist applications. Be sure to completely read Section 8 to apply these features and functions.

X-Press Initial Values for Three-Speed Multi-Step Control Mode					
Constant	Description	Bridge/Trolley X-Press Data = 02		Hoist X-Press Data = 07	
no-02	Enables changing of constants	Must be data 02			
no-01	Motor rated current	Motor Nameplate Amps			
no-03	Multi-Step speed 1/Minimum speed	6.0 Hz			
no-04	Multi-step speed 2	15.0 Hz			
no-05	Multi-step speed 3	30.0 Hz			
no-06	Multi-step speed 4	45.0 Hz			
no-07	Multi-step speed 5	60.0 Hz			
no-08	Acceleration time	5.0 Seconds			
no-09	Deceleration time	3.0 Seconds			
no-13, D3	Stopping method selection*	0		1	
		230 Volts	460 Volts	230 Volts	460 Volts
no-47	V/F Pattern Selection Setting	16.1	32.2	24.1	48.2
no-49	V/F Pattern Selection Setting	9.2	18.4	17.2	34.4
no-44	Input Voltage (actual)	230/460			

* Default stopping method is **immediate stop**. Extreme caution should be used when changing to deceleration at STOP command. A long deceleration time will cause driven equipment to require a greater stopping distance.

7.3 Five-Speed Multi-Step Control Method (X-Press Constant no-00 = 02 or 07)

Specific settings and control circuit connections are required to begin five-speed multi-step control operation. The recipe requires both control circuit connections and specific programming changes via the digital keypad.

7.3.1 Control Circuit Wiring Diagram for Five-Speed Multi-Step Control

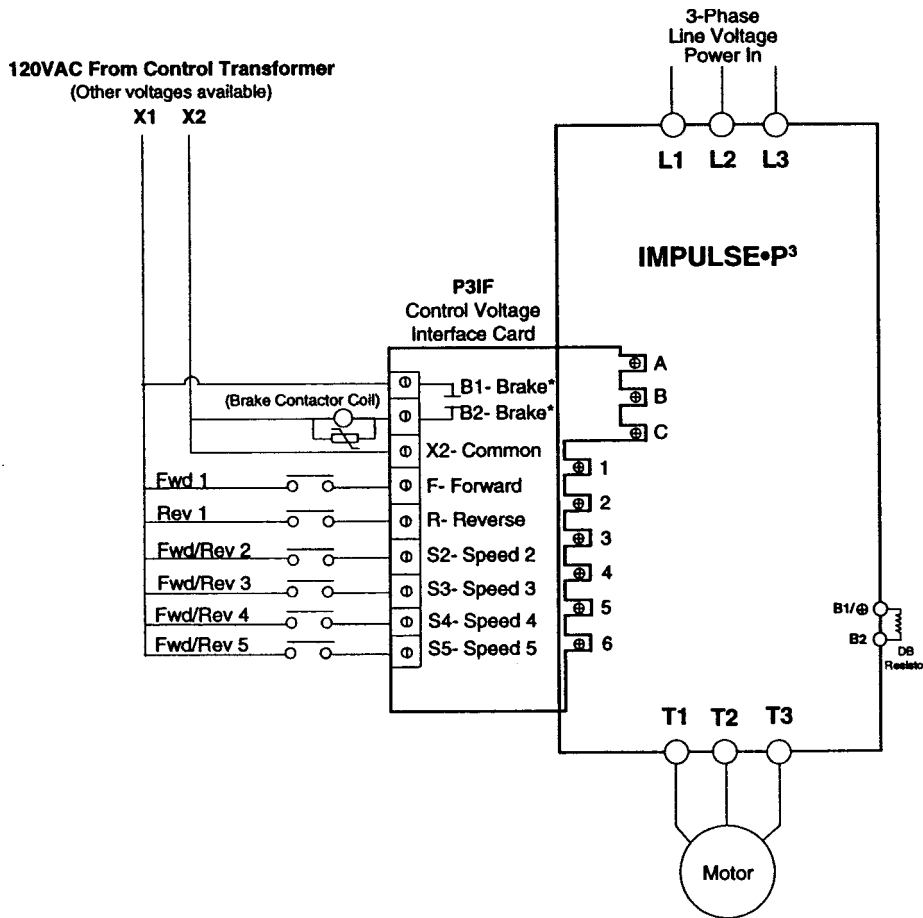

*Note: Brake contact rated for 250 VAC, ≤ 1 Amp

7.3.2 Input/Output Reference for Five-Speed Multi-Step Control

In the following chart, X = 120 VAC input to terminals of P3IF; O = 0 VAC input to terminals of P3IF; — = not applicable.

Terminals X2-F (R)	Terminals X2~2	Terminals X2~3	Terminals X2~4	Terminals X2~5	Action
O	—	—	—	—	STOP*
X	O	O	O	O	Runs at Hz of Constant no-03
X	X	O	O	O	Runs at Hz of Constant no-04
X	X	X	O	O	Runs at Hz of Constant no-05
X	X	X	X	O	Runs at Hz of Constant no-06
X	X	X	X	X	Runs at Hz of Constant no-07
Terminals used for five-step control					

* Default stopping method is **immediate stop**. Extreme caution should be used when changing to deceleration at STOP command. A long deceleration time will cause driven equipment to require a greater stopping distance.

7.3.3 X-Press Settings for Other Constants (Five-Speed Multi-Step Control)

IMPORTANT:

- The X-Press values were established from our experience in the crane and hoist industry. These values have been proven typical for the crane and hoist builder. Actual setting values should be determined by the specific application. (See Section 5 for more information.)
- Only those values typically changed from Electromotive Systems' initial values are indicated in the table below. Please read and understand Section 5 completely before proceeding with programming. There may be constants and functions not listed below that will increase the application precision of IMPULSE•P³.
- Electromotive Systems' software includes powerful and useful functions for crane and hoist applications. Be sure to completely read Section 8 to apply these features and functions.

X-Press Initial Values for Five-Speed Multi-Step Control Mode					
Constant	Description	Bridge/Trolley X-Press Data = 02		Hoist X-Press Data = 07	
no-02	Enables changing of constants	Must be data 02			
no-01	Motor rated current	Motor Nameplate Amps			
no-03	Multi-Step speed 1/Minimum speed	6.0 Hz			
no-04	Multi-step speed 2	15.0 Hz			
no-05	Multi-step speed 3	30.0 Hz			
no-06	Multi-step speed 4	45.0 Hz			
no-07	Multi-step speed 5	60.0 Hz			
no-08	Acceleration time	5.0 Seconds			
no-09	Deceleration time	3.0 Seconds			
no-13, D3	Stopping method selection*	0		1	
		230 Volts	460 Volts	230 Volts	460 Volts
no-47	V/F Pattern Selection Setting	16.1	32.2	24.1	48.2
no-49	V/F Pattern Selection Setting	9.2	18.4	17.2	34.4
no-44	Input Voltage (actual)	230/460			

* Default stopping method is **immediate stop**. Extreme caution should be used when changing to deceleration at STOP command. A long deceleration time will cause driven equipment to require a greater stopping distance.

7.4 Two-Step Infinitely Variable Control Method (X-Press Constant no-00 = 03 or 08)

Specific settings and control circuit connections are required to begin two-step infinitely variable control operation. The recipe requires both control circuit connections and specific programming changes via the digital keypad.

7.4.1 Control Circuit Wiring Diagram for Two-Step Infinitely Variable Control

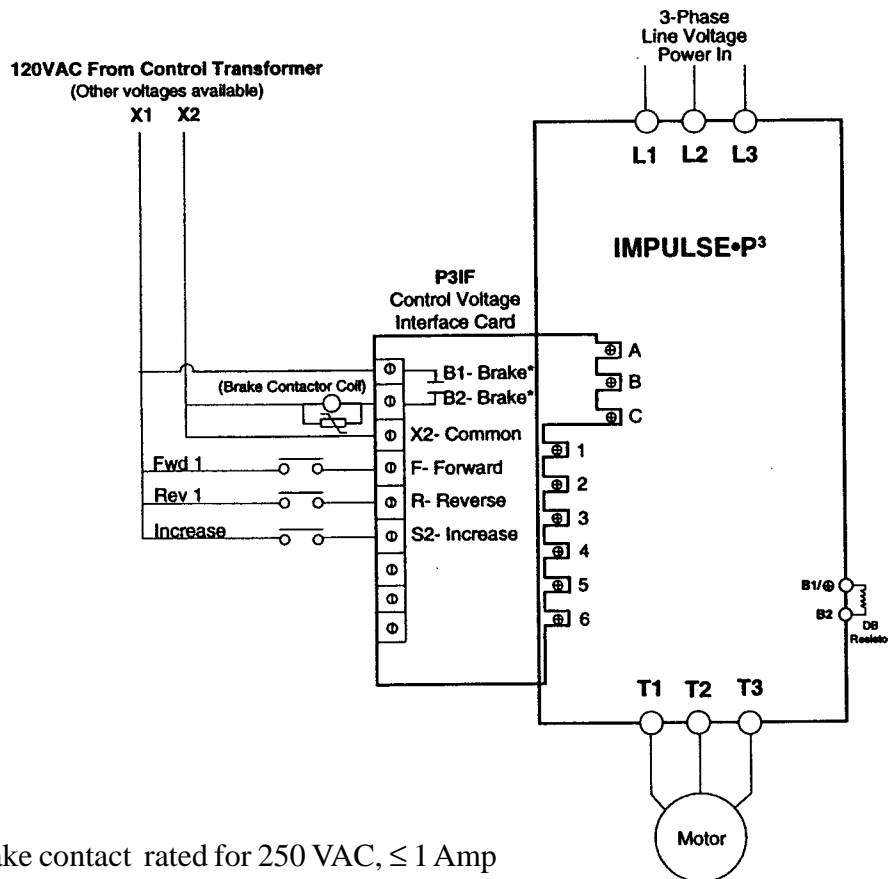

*Note: Brake contact rated for 250 VAC, ≤ 1 Amp

7.4.2 Control Circuit Input Sequence for Two-Step Infinitely Variable Speed Control

In the following chart, X = 120 VAC input to terminals of P3IF; O = 0 VAC input to terminals of P3IF; — = not applicable.

Terminals X2~F (R)	Terminals X2~2	Action
O	—	STOP*
X	O	Runs at Hz of Constant no-03/Holds Frequency
X	X	Increasing Frequency
Terminals used for two-to five-step control		

* Default stopping method is **immediate stop**. Extreme caution should be used when changing to deceleration at STOP command. A long deceleration time will cause driven equipment to require a greater stopping distance.

7.4.3 X-Press Settings for Other Constants (Two-Step Infinitely Variable Control)

IMPORTANT:

- The X-Press values were established from our experience in the crane and hoist industry. These values have been proven typical for the crane and hoist builder. Actual setting values should be determined by the specific application. (See Section 5 for more information.)
- Only those values typically changed from Electromotive Systems' initial values are indicated in the table below. Please read and understand Section 5 completely before proceeding with programming. There may be constants and functions not listed below that will increase the application precision of IMPULSE•P³.
- Electromotive Systems' software includes powerful and useful functions for crane and hoist applications. Be sure to completely read Section 8 to apply these features and functions.

X-Press Initial Values for Two-Step Infinitely Variable Speed Control Mode					
Constant	Description	Bridge/Trolley X-Press Data = 03		Hoist X-Press Data = 08	
no-02	Enables changing of constants	Must be data 02			
no-01	Motor rated current	Motor Nameplate Amps			
no-03	Lower Limit/Minimum speed	6.0 Hz			
no-07	Upper limit	60.0 Hz			
no-08	Acceleration time	5.0 Seconds			
no-09	Deceleration time	3.0 Seconds			
no-13, D3	Stopping method selection*	0		1	
		230 Volts	460 Volts	230 Volts	460 Volts
no-47	V/F Pattern Selection Setting	16.1	32.2	24.1	48.2
no-49	V/F Pattern Selection Setting	9.2	18.4	17.2	34.4
no-44	Input Voltage (actual)	230/460			

* Default stopping method is **immediate stop**. Extreme caution should be used when changing to deceleration at STOP command. A long deceleration time will cause driven equipment to require a greater stopping distance.

**7.5 Three-Step Infinitely Variable Control Method
(X-Press Constant no-00 = 04 or 09)**

Specific settings and control circuit connections are required to begin three-step infinitely variable control operation. The recipe requires both control circuit connections and specific programming changes via the digital operator keypad.

7.5.1 Control Circuit Wiring Diagram for Three-Step Infinitely Variable Control

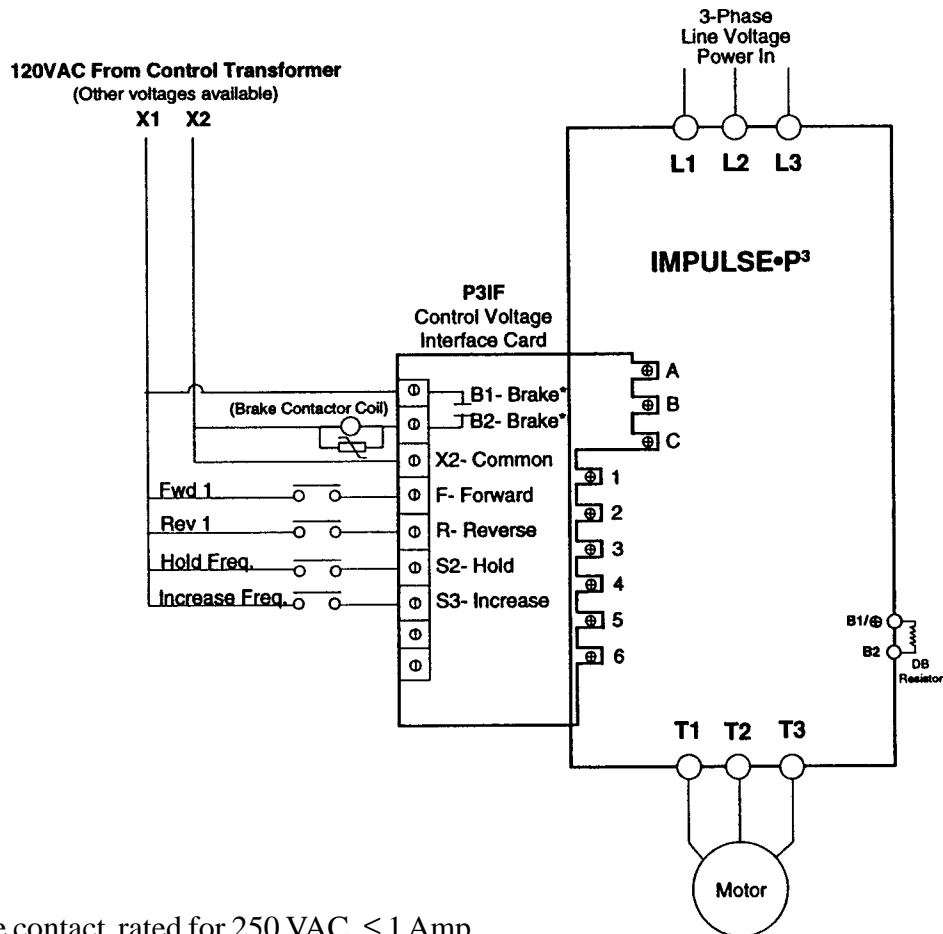

*Note: Brake contact rated for 250 VAC, ≤ 1 Amp

7.5.2 Control Circuit Input Sequence for Three-Step Infinitely Variable Speed Control

In the following chart, X = 120 VAC input to terminals of P3IF; O = 0 VAC input to terminals of P3IF; — = not applicable.

Terminals X2~F (R)	Terminals X2~2	Terminals X2~3	Action
O	—	—	STOP*
X	O	O	Runs at Hz of no-03
X	X	O	Holds Frequency
X	X	X	Increasing Frequency
Terminals used for three-step infinitely variable control			

* Default stopping method is **immediate stop**. Extreme caution should be used when changing to deceleration at STOP command. A long deceleration time will cause driven equipment to require a greater stopping distance.

7.5.3 X-Press Settings for Other Constants (Three-Step Infinitely Variable Control)

IMPORTANT:

- The X-Press values were established from our experience in the crane and hoist industry. These values have been proven typical for the crane and hoist builder. Actual setting values should be determined by the specific application. (See Section 5 for more information.)
- Only those values typically changed from Electromotive Systems’ initial values are indicated in the table below. Please read and understand Section 5 completely before proceeding with programming. There may be constants and functions not listed below that will increase the application precision of IMPULSE•P³.
- Electromotive Systems’ software includes powerful and useful functions for crane and hoist applications. Be sure to completely read Section 8 to apply these features and functions.

X-Press Initial Values for Three-Step Infinitely Variable Speed Control Mode					
Constant	Description	Bridge/Trolley X-Press Data = 04		Hoist X-Press Data = 09	
no-02	Enables changing of constants	Must be data 02			
no-01	Motor rated current	Motor Nameplate Amps			
no-03	Lower Limit/Minimum speed	6.0 Hz			
no-07	Upper limit	60.0 Hz			
no-08	Acceleration time	5.0 Seconds			
no-09	Deceleration time	3.0 Seconds			
no-13, D3	Stopping method selection*	0		1	
		230 Volts	460 Volts	230 Volts	460 Volts
no-47	V/F Pattern Selection Setting	16.1	32.2	24.1	48.2
no-49	V/F Pattern Selection Setting	9.2	18.4	17.2	34.4
no-44	Input Voltage (actual)	230/460			

* Default stopping method is **immediate stop**. Extreme caution should be used when changing to deceleration at STOP command. A long deceleration time will cause driven equipment to require a greater stopping distance.

7.6 To Enable/Disable Electronic Motor Thermal Overload Protection

The IMPULSE•P³ contains a sophisticated software algorithm which actually monitors the motor's operating conditions (current and speed) over a period of time. This data is used in a motor thermal simulation within the inverter, so the inverter is continuously checking for possible motor overload conditions. There are two programming constants which should be set to tune this motor protection. These are protective characteristics (constant no-14) and motor rated current (constant no-01).

The initial setting for this motor overload protection is enabled. We suggest you leave this protective function enabled. However, if you choose to disable this function, set constant 14 digit 1 = 1 and install separate motor thermal overload relays or motor klixons/thermistors for each individual motor (per NEC requirements).

Protective Characteristics (constant no-14): initial setting = 0100.

Digit 1 Motor overload enable/disable
0 Function is **enabled**
1 Function is **disabled**

Digit 2 Motor type
0 Standard motor
1 Inverter motor

Digit 3 Thermal time constant
0 Continuous motor
1 Short time rated motor

Digit 4 Not related to this function

Motor Rated Current (constant no-01): initial setting depends on inverter rating

This programming constant should be set to match the motor's actual nameplate current. This is similar to selecting the proper heater element for a conventional motor overload relay.

Section 8: Special Features of IMPULSE•P³

IMPULSE•P³ has a unique combination of hardware features tailored to provide safe and optimum performance for overhead material handling applications. This section describes powerful and unique features of IMPULSE•P³ Adjustable Frequency Drives.

Safety features of IMPULSE•P³

- STOP button operation
- RUN button operation
- Automatic Keypad Lockout™

Performance features of IMPULSE•P³

- Quick Stop™
- Reverse Plug Simulation™
- Swift Lift™

8.1 Safe Operating Windows™

IMPULSE•P³ was developed with a wide range of capabilities which allow it to operate successfully and efficiently in a variety of applications. Due to the unique operational and demanding safety concerns found in overhead material handling applications, every IMPULSE•P³ is provided with Electromotive Systems' Safe Operating Windows. This is a built-in feature with X-Press Programming. Safe Operating Windows actually adjusts the drive operating characteristics to allow optimum performance and maximum safety in crane and hoist environments. The possibility of programming the drive with unsafe values is reduced, avoiding situations where a crane may not be able to lift a load, or not be able to stop in a safe distance.

8.1 Safe Operating Windows™ (Continued)

		Some Typical AFDs	IMPULSE•P ³
Allowable Speed Range	Torque is greatly reduced under 1.5 Hz and over 150 Hz	0-400 Hz	1.5-150 Hz
Deceleration Time	Long deceleration time may be dangerous for traveling cranes on shorter runways	0-6,000 seconds	.5-25 Seconds
Absolute Minimum Speed Output	Torque is greatly reduced below 1.5 Hz	0 Hz	1.5 Hz
Programmable Minimum Voltage	Torque is greatly reduced below 1.5 Hz, and if there is not sufficient voltage to provide motor magnetizing current	0 Volts	7 Volts @ 1.5 Hz
Default Setting of Stopping Mode	Immediate Stop/Base Block is required on hoist applications	Ramp to Stop	Immediate Stop
Stall Prevention During Decel	Deceleration time can be automatically extended if enabled, overriding Quick Stop function	Enabled	Disabled
Keypad Status During Power-Up	–	Read and Write	Read Only
Initial Default Program Values	Acceleration Time	10 Seconds	5 Seconds
	Deceleration Time	10 Seconds	3 Seconds
	Speeds 1 to 5	0 - 0 Hz	6 - 60 Hz

If your application has special conditions or requirements, contact Electromotive Systems.

8.2 Safety Features of IMPULSE•P³

8.2.1 STOP Button Operation

The STOP button on the digital keypad is always active (both in the drive and program modes). Depressing the STOP button stops the drive according to the programmed stopping method.

8.2.2 RUN Button Operation

The RUN button on the digital keypad operates differently than typical general purpose inverters. Safe operation of cranes and hoists in the local operation mode demands that operation only be possible when the RUN button is depressed. The **absence** of a RUN command demands STOP. This reduces the possibility of a runaway crane.

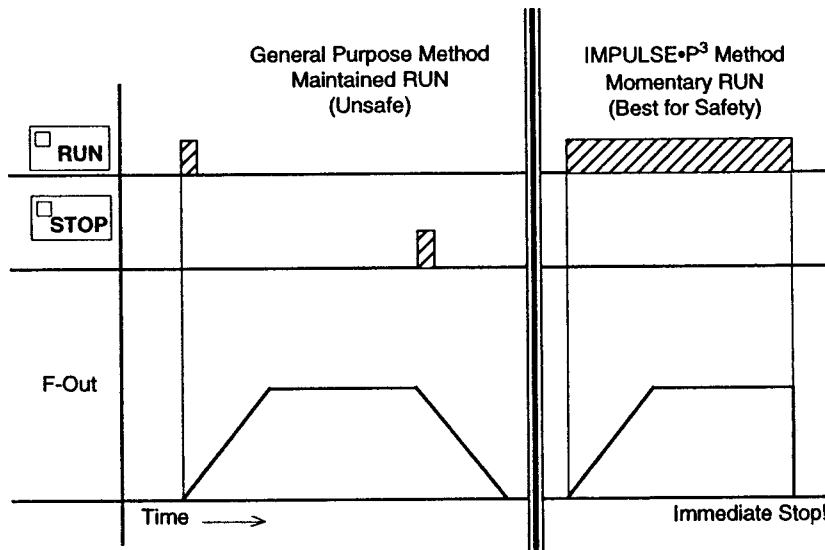

8.2.3 Automatic Keypad Lockout

IMPULSE•P³ automatically prohibits the user from making unwanted and potentially unsafe data changes. This keeps unauthorized personnel from changing drive set-up parameters, and reduces the possibility of programming unsafe values and creating unsafe operation. Even if a service person forgets to reset constant no.-02, the IMPULSE•P³ automatically resets this value upon the next power-up.

8.3 Quick Stop

Quick Stop provides an automatic alternate decel time changeover at STOP command. This function provides for increased positioning accuracy and shortens the deceleration time at STOP command to within the safe operating limits of the equipment. Quick Stop ensures a rapid deceleration to stop once a drive RUN command is removed, and reduces the possibility of a crane collision.

8.3.1 Quick Stop Programming Method

Enable by constant no-10, digit 1 = 1

8.3.2 Quick Stop Timing Chart

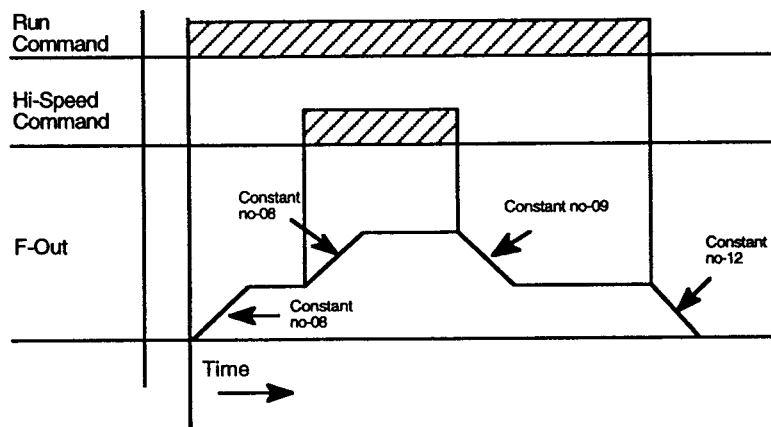

8.4 Reverse Plug Simulation

Reverse Plug Simulation allows an operator to change direction of travel quickly. This function closely simulates the operation of systems utilizing conventional reversing contactor type controls. Operators are comfortable with the rapid deceleration achieved when plug reversing standard motors. This function allows an operator to smoothly and quickly stop in the direction of travel, then quickly accelerate in the opposite direction.

8.4.1 Reverse Plug Simulation Programming Method

Enable by constant no-10, digit 2 = 1

8.4.2 Reverse Plug Simulation Timing Chart

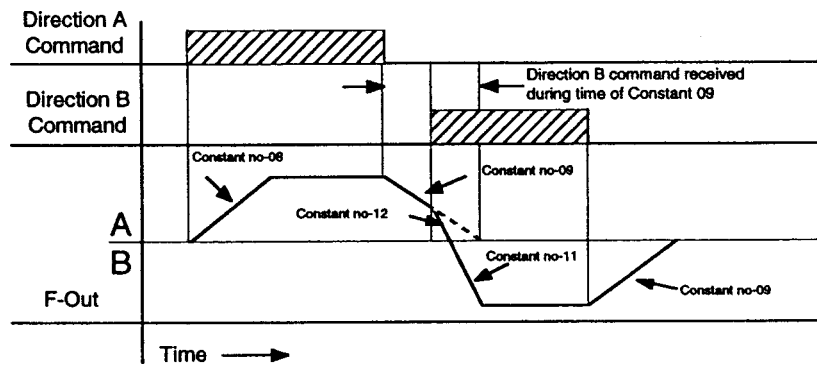

8.5 Swift Lift Overspeed Operation

Swift Lift automatically provides for increased speed of operation under light or no load conditions. This is an automatic function when enabled, and is variable depending on the load. Swift Lift provides additional productivity by allowing a crane or hoist hook to be moved into position more quickly.

DC drives for hoists and cranes have always offered extended speed ranges via field weakening. While this function has never been automated, the feature can offer benefits of higher system throughput by shrinking the “dead-time” between lifting and lowering loads. The IMPULSE•P³ adjustable frequency drive has an output frequency capability above 60 Hz. This capability beyond base speed (60 Hz) is utilized by Swift Lift. The IMPULSE•P³ monitors its own output current which is proportional to load when the motor is running at a constant speed. If the output current is below a programmable parameter, the drive will automatically accelerate to a higher frequency. For example: A given hoist is rated for 15 FPM. Under certain conditions of “no load”, the rated speed of the hoist can be increased to 30 FPM (or any other speed below 200%)

NOTE: Please consider all the mechanical components’ rotating speeds before enabling Swift Lift. Permission from the component manufacturer may be required for safe Swift Lift operation.

8.5.1 Swift Lift Programming Method

Enabled by constant no-10, digit 3=1

Constant 21 = Swift Lift enable current at forward

- If current during forward operation constant no-21, then Swift Lift enabling procedure continues.

Constant 22 = Swift Lift enable current at reverse

- If current during reverse operation constant no-22, then Swift Lift enabling procedure continues.

Constant 23 = Swift Lift delay timer

- The last function of the Swift Lift enabling procedure—after reaching the threshold frequency (constant no-07), and detecting that current is \leq constant no-21 (constant no-22), then the Swift Lift delay timer is enabled.

Constant 20 = Swift Lift maximum frequency

- After enabling procedure is completed, actual frequency output is determined by F-Out = constant no-20.

8.5.2 Swift Lift Flow Chart

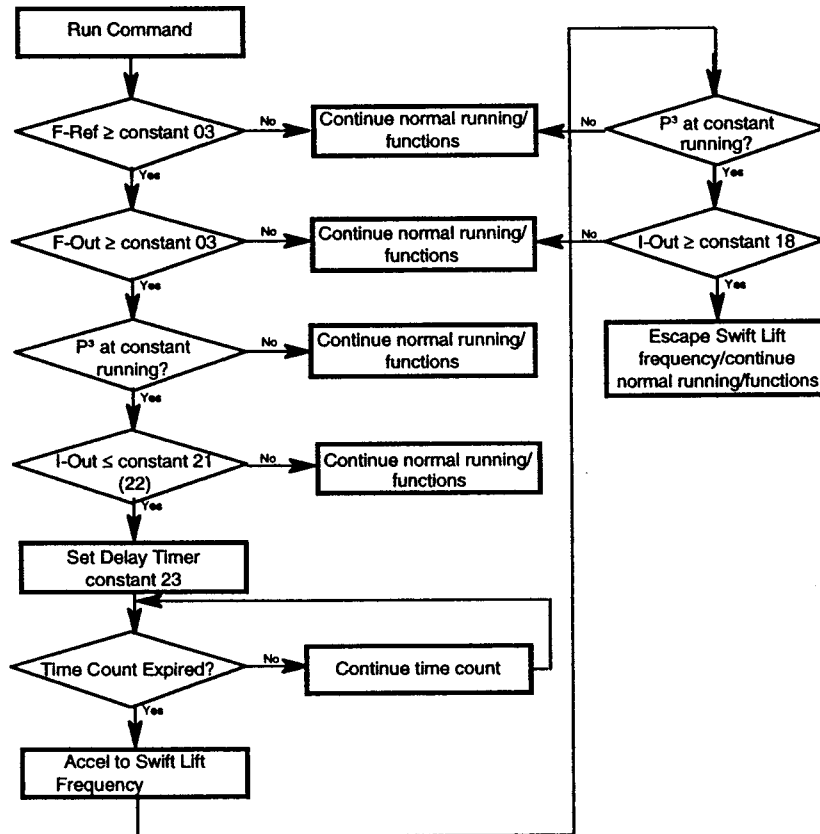

Section 9: Checks Before Operation

After mounting and interconnections are completed, please check for:

- Correct connections.
- Correct input power supply. (No voltage drop or imbalance, source KVA \leq 500.)
Please note that 460V input to 230V series control will destroy power section of unit!
- No short circuit conditions.
- No loose screw terminals.
- Check for loose wire clippings.
- Proper load conditions.

Precautions:

- Only start the motor if motor shaft rotation is stopped.
- Even with small loading, never use a motor whose nameplate amperage exceeds the inverter rated current.
- When starting and stopping the motor, be sure to use the operation signals (fwd/rev), not the magnetic contactor on the power supply side.

**CAUTION**

Braking method selection as shipped from Electromotive Systems is set for immediate stop at STOP command. If changed to decelerate at STOP command, then extreme caution should be used during deceleration. If deceleration time is too long, equipment could run into endstop device, causing damage to equipment or injury to personnel.

Section 10: Maintenance

IMPULSE•P³ requires almost no routine check. It will function more efficiently and last long if it is kept clean, cool and dry, observing the precautions listed in Section 2.1. Check for tightness of electrical connections, discoloration or other signs of overheating.

 **W A R N I N G**

During service inspection, turn off AC main circuit power and wait at least ten minutes before touching any circuit components. The red charge lamp must be fully extinguished before touching any components. Failure to adhere to this warning could result in serious injury.

Section 11: Troubleshooting

This is perhaps some of the most important information in this manual. Because equipment downtime is in most situations not tolerable, diagnosing, troubleshooting and correcting problems are the most critical aspects of applying adjustable frequency technology to overhead material handling equipment.

Section 11 is designed to simplify the task of troubleshooting by presenting logical procedures and step by step advice on how to get the equipment up and running efficiently. Remember, effective troubleshooting means following a logical sequence.

11.1 Troubleshooting 101- Where to Begin

The first step is to clearly identify all the symptoms. To simplify matters, we can divide all symptoms into two basic groups:

Symptom #1: Equipment will not operate.

Symptom #2: Equipment operates, but operation is either intermittent or not acceptable (i.e. motor does not accelerate, only one direction is achieved, motor stops running quite frequently).

In addition to identifying the symptoms, it is important that you follow this additional basic advice for efficient troubleshooting:

- Gather all pertinent information relating to the problem.
- Eliminate possible causes.
- Document everything.

11.1.1 Troubleshooting for Symptom #1- Equipment Will Not Operate

Following these steps will greatly reduce the time it takes to determine a solution to the problem.

Step 1: Check for visible signs of damage to IMPULSE•P³ or related components. If found, DO NOT operate the drive.

- A. Measure and record incoming line-to-line supply voltage (L1, L2, L3).
- B. Call Electromotive Systems at 800/288-8178.

Step 2: If there are no signs of visible damage, apply power and verify that the “CHARGE” lamp is lit.

- A. If not, call Electromotive Systems.

Step 3 With power on, identify the keypad display:

- A. Is keypad blank? If yes:
 - 1. Measure and record incoming line-to-line supply voltage (L1, L2, L3).
 - 2. Call Electromotive Systems.
- B. Is a Fault Code displayed (as found in Section 11.3)?
 - 1. Record Fault Code.
 - 2. Refer to Section 11.2 for possible solutions to common fault conditions.
 - 3. If fault code is listed, take appropriate action as prescribed in Section 11.2 and 11.3.
 - 4. If fault code is not listed in Section 11.3, or for further assistance, call Electromotive Systems.
 - 5. Attempt to run motor.
 - 6. If operation fails, call Electromotive Systems.

11.1.1 Troubleshooting for Symptom #1-Equipment Will Not Operate (Continued)

- C. Is IMPULSE•P³ in the DRIVE mode (or mistakenly in the programming mode)?
 - 1. Ensure that the DRIVE lamp on the upper left hand corner of the keypad is lit.
 - 2. If not, depress [DRIVE/PROGRAM] key.
 - 3. Attempt to run motor.
- D. Is IMPULSE•P³ set up for remote operation (i.e. from a pushbutton station, for example)?
 - 1. Ensure that the SEQ and REF lamps located on the upper right hand corner of the keypad are lit.
 - 2. If not, IMPULSE•P³ may be set up for local operation. In this case, you must change constant no-13 to digit 02, data 1.
NOTE: Please refer to Section 5 of this manual if you have no prior experience in programming IMPULSE•P³. Or, call Electromotive Systems for assistance.
 - 3. Attempt to run motor.
- E. Is the keypad display normal (i.e. 0.0 for monitoring output frequency)?
 - 1. If not, change the display mode by depressing the [DISPLAY] key until 0.0 appears.
 - 2. Proceed to Step 4.

Step 4: If steps 1 through 3 have not solved the problem, the following wiring checks should be made:

- A. Check all terminals of the IMPULSE•P³ for loose connections or strayed wires. Be sure that the ground terminal is connected.
- B. Check all motor connections for loose wires, and check for proper motor lead connection to the inverter.
- C. Check for discontinuities in the control circuit wiring external to the drive. Especially check for:
 - 1. Continuity on all pushbutton (or radio, infra-red, joysticks, etc.) wiring.
 - 2. Motor klixons open.
 - 3. Limit switches open.
 - 4. External thermal overload contact open.

Ensure that IMPULSE•P³ is connected in the prescribed manner, and that all connections, both power and control, are correct. Refer to Section 3 of this manual, or the appropriate wiring diagram accompanying IMPULSE•P³ for more details

Step 5: If following steps 1 through 4 did not result in successful operation, call the Service Department at Electromotive Systems, Inc. immediately for further assistance. Do not attempt to make any programming changes to IMPULSE•P³ unless you've had previous experience in the set-up and adjustment of the unit.

11.1.2 Troubleshooting for Symptom #2-Equipment Operates, but Operation is Either Intermittent or not Acceptable

Following these steps will greatly reduce the time it takes to determine a solution to the problem.

Step 1: Is there a fault condition?

- A. Run the equipment.
- B. When operation stops, observe the keypad display and record the Fault Code.
- C. Refer to Section 11.2 for possible solutions to common fault conditions.
- D. If fault code is listed, take appropriate action as prescribed in Sections 11.2 and 11.3.
- E. If fault code is not listed in Section 11.2 or 11.3, call Electromotive Systems.
- F. Run the equipment.
- G. If intermittent operation continues:
 1. Record the Fault Code.
 2. Try to determine when the fault is occurring (i.e. at what point during operation does the equipment stop running).
 3. Call Electromotive Systems.

Step 2: Check all external wiring

- A. Refer to Step 4 of Section 11.1.1 for details.

Step 3: If following steps 1 and 2 have not resulted in successful operation, call the Service Department at Electromotive Systems, Inc. immediately for further assistance. Do Not attempt to make any programming changes to IMPULSE•P³ unless you have had previous experience in the set-up and adjustment of the unit.

11.2 Possible Solutions to Common Fault Codes

The following are common fault codes that may be displayed on the keypad for overhead material handling applications. **If the solution involves programming of the IMPULSE•P³, do not attempt to solve the problem unless you are experienced in the set-up and adjustment of the unit.** If you are unsure about any of the solution methods, or the problem persists after correction steps have been taken, consult the Service Department at Electromotive Systems immediately for application assistance.

OC (Overcurrent)

1. *Check all external wiring and ensure that proper wiring precautions are being followed. Especially check for ground faults or short circuits at the output of the inverter.
2. Check for proper Volts/Hertz relationship.
3. Lengthen acceleration time, if possible.

*If using a megger for step #1, disconnect motor leads from inverter.

11.2 Possible Solutions to Common Fault Codes (Continued)

OV (Overvoltage)

1. Check input supply voltage (L1, L2, L3). Is it within the specified rating?
2. Check all external wiring and wiring precautions.
3. Verify that the proper dynamic braking resistance is applied. Call Electromotive Systems if it is not clear how to verify this, or what resistor is required.
4. Lengthen the deceleration time, if possible.

OL1 (Overload-protect the motor)

- Reduce the load.
- The motor overload protection function of IMPULSE•P³ is not programmed for the proper motor FLA's.

OL2 (Overload-protect the inverter)

- Reduce the load.
- Consult Electromotive Systems. IMPULSE•P³ (or the motor) may be undersized.

EF4, EF5 (External Fault)

- Check the condition of the control inputs of the P3IF.
- Check programming of no-33 (terminal S4).
- Check programming of no-34 (terminal S5).

PB (Pushbutton Sequence)

- Check that all speed inputs are being received in proper sequence (i.e., Fwd or Rev 1st speed, then 2nd speed, then 3rd speed, etc.). A PB fault could signal either an open control conductor or improper wiring of the control inputs.

FU (Fuse Blown)

- Consult Electromotive Systems immediately.

CPFxx

















- Refer to section 11.3 for fault description.
- Consult Electromotive Systems immediately. Record the two digits following CPF.

11.3 Listing of Fault Codes

Fault Display		Status	Possible Cause	Recommended Action
Digital Keypad	Passive Cover Display			
	DS1			
OC Overcurrent		Inverter output current exceeds 200% of rated current. Output shuts off.	Inverter output side short-circuit; excessive load inertia; excessively short setting of accel/decel time; special motor start during coasting; start of motor with larger capacity than inverter.	Check all external wiring and ensure that proper wiring precautions are being followed. Especially check for group faults or short circuits at the output of the inverter; Check for proper Volts/Hertz relationship; Lengthen acceleration time, if possible.
GF Ground Fault		Inverter output side is grounded. Output shuts off.	Inverter output side is grounded.	Check that the motor or load side wiring is not grounded; check that motor insulation is not deteriorated; check that wiring of load side is not damaged.
OV Overvoltage		Main circuit DC voltage exceeds 410V or more for 230V class, (820V or more for 460V class) because of excessive regenerative energy from the motor. (Exceeds overvoltage protection level.) Output shuts off. High Input line voltage.	Decel time setting is not sufficient; high input voltage line; Dynamic braking circuit not functioning.	Check input supply voltage (L1, L2, L3). Is it within the specified rating?; Check all external wiring and wiring precautions; Verify that the proper dynamic braking resistance is applied. Call Electromotive Systems if it is not clear how to verify this, or what resistor is required; Lengthen the deceleration time, if possible.
UV Undervoltage		Inverter output is stopped when the main circuit DC voltage becomes lower than the low voltage detection level. (Detection level: approximately 210V or less 230V; 420V-460V)	Inverter capacity is too small; voltage drop due to wiring; a motor of large capacity connected to the same power system has been started; rapid acceleration with generator power supply; defective electromagnetic contactor.	Check that main circuit power supply wiring is connected properly and terminal screws are tightened well; check the power supply voltage; check the power capacity and power system; check input diode section.
OH Cooling Fin Overheat		Temperature rise caused by inverter overload operation, or intake air temperature rise. The inverter output is shut off when the cooling fin overheat is detected by thermistor.	Load is too large; V/f pattern is not proper; Intake air temperature exceeds 113°F (45°C); Excessive dirt on cooling fins.	Correct load size. V/f set value or intake air temperature; Clean cooling fins.

:Light :Blink :Light Off

11.3 Listing of Fault Codes (Continued)

Fault Display		Status	Possible Cause	Recommended Action	
Digital Keypad	Passive Cover Display				
	DS1				DS2
OL1 Motor Overload			The inverter output is stopped when excessive output current to the motor is detected by the electronic thermal overload in the inverter.	Overload, long operation at low speed; improper V/f pattern setting; motor rated current setting is wrong	Investigate the cause of overload and review the operation, V/f pattern, and motor/inverter capacities. Set no-01 = current of motor to nameplate value; Check for proper programming of no-14.
OL2 Inverter overload			The inverter's overload protection has detected 150% output current for 1 minute.	Overload, long operation at low speed; improper V/f pattern setting.	Correct load size, operation or V/f pattern; recheck the inverter capacity.
OL3 Overtorque Detection			Motor current exceeding set value of no-18 for the amount of time set in no-19.	Overload	Check for proper programming of no-18 and no-19; reduce load.
EF4, EF5 External Fault			When an external fault signal is input, the inverter output is shut off.	External fault condition occurred.	Check the condition of the control input of the P3IF; Check programming of no-33 (terminal S4) or no-34 (terminal S5).
CPF00 Control Function Fault			Initial memory fault is detected	External noise; excess vibration or shock; the inverter output is shut-off when a transmission error occurs in the control circuit or a component fails.	Record all constants, and then set no-00 = OA to initialize; turn off power supply until charge lamp is extinguished and then turn it on again; if the fault still exists, call Electromotive Systems; If fault has cleared, restore recorded constants.
CPF01 Control Function Fault			ROM fault is detected		
CPF04 Control Function Fault			Constant fault is detected		
CPF05 Control Function Fault			AD converter fault is detected.		

: Light : Blink : Light Off

11.3 Listing of Fault Codes (Continued)

Fault Display		Status	Possible Cause	Recommended Action	
Digital Keypad	Passive Cover Display				
	DS1				DS2
EF Blinks Simultaneous input forward and reverse commands	<input type="checkbox"/>	<input type="checkbox"/>	When forward and reverse run commands are simultaneously closed for a period of time exceeding 500 mS, the inverter is stopped according to the preset stop method.	Operation sequence error.	Check pendant; Check the control interface circuit; recheck the control sequence.
BB External Base Block	<input type="checkbox"/>	<input checked="" type="checkbox"/>	External base block is input; inverter output shuts off; operation restarts when the external base block signal is removed.	External base block is input.	Check programming of no-32, 33 and 34.
UV blinks Main Circuit Undervoltage	<input type="checkbox"/>	<input checked="" type="checkbox"/>	Main circuit DC voltage is reduced less than detection level when inverter is not outputting. Detection level: approximately 210V or less (230V); approximately 420V or less (460V).	Main circuit DC voltage is reduced less than detection level when inverter is not outputting.	Check the power supply voltage; main circuit power supply wiring connection; or terminal screw tightening.
OL3 blinks Overtorque Detection	<input type="checkbox"/>	<input checked="" type="checkbox"/>	Motor current exceeding the set value of no-18 for time in no-19. Inverter continues operation due to no-17, digit 3.	Motor current exceeding the set value of no-18 for time in no-19. Inverter continues operation due to no-17, digit 3.	Check for proper programming of no-18 and no-19; reduce the load.
OV blinks	<input type="checkbox"/>	<input checked="" type="checkbox"/>	Main circuit DC voltage rises above the detection level while the inverter output is off. Detection level: 410V or more for 230V, (820V or more for 460V).	—	Check the power supply voltage.
OH blinks	<input type="checkbox"/>	<input checked="" type="checkbox"/>	Intake air temperature rises when inverter is not outputting.	Load is too large; V/f pattern not proper; Intake air temperature exceeds 113°F (45°C); Excessive dirt on cooling fins.	Correct load size, V/f set value or intake air temperature; Clean cooling fins.

:Light :Blink :Light Off

- 1) Use surge absorbers (R-C networks) on all relay and contactor coils.
- 2) Shielded cable shall be used for all low level D.C. speed reference signals (0-10VDC, 4-20 mA). Shield should be grounded only at the drive side.
- 3) Use a minimum of #16 AWG for control wiring, and #12 AWG (or larger) for power wiring. Size according to N.E.C. table 310-16.
- 4) The following is required for all dual motor bridge cranes and suggested for center driven cranes, trolleys and hoists. Upsize the wiring one size for every 25 feet of distance between drive and motor to account for voltage drop (which becomes significant at low frequencies).
- 5) Use time delay fuses for drive input protection. They shall be sized at approximately 150% of drive continuous rated ampacity.
- 6) Control the power wiring (including dynamic braking resistor wiring) shall be kept separate on terminal block strip.
- 7) Keep control (directional and speed command inputs to the drive) and power wiring from running together in parallel paths on the panel or in conduit runs. Keep control and power festoon wiring in different cables and separated.
- 8) If control and power wiring do meet on a panel, cross them perpendicularly.
- 9) Before applying power to the drive, check the output circuit (T1, T2, T3) for possible short circuits or ground faults.
- 10) Always mount the drive in its proper (vertical) orientation, clearances listed in section 2.2. Drives should be housed in appropriate NEMA rated enclosures for the environment in which they will be used.
- 11) Keep drive heatsink clear of any obstructions (components on panel) to ensure proper cooling air flow.
- 12) If using externally mounted interface boards, or remotely mounted speed reference signals, use shielded cable from the interface output or remote speed reference to the drive control input terminals.
- 13) On external input devices (control), hard contact inputs are preferred rather than solid state inputs into the control voltage input board.

- 14) If the input device is a PLC triac output, a 5K ohm, 10 watt resistor may have to be used between the signal and common (X2).
- 15) Drives should always have the cover mounted on unit during normal operating conditions to protect the internal components.
- 16) One ground terminal or screw (“G” or “E”) must be grounded back to earth ground.
- 17) If the power source is greater than 500 KVA, there should be at least 3% impedance in the line between the source and the input to the drive.
- 18) Incoming power supply voltage must be limited to 230 volts \pm 10% or 460 volts \pm 10%.
- 19) On existing wound rotor motor applications, a line reactor of 3% impedance may be required on the load side of the drive.
- 20) When using more than one transformer for control power, properly phase each transformer with respect to the other(s).
- 21) All line and ground wiring should be disconnected when any welding is being done on or to the crane.
- 22) When supplying single phase input to the drive, the ampacity of the drive must be derated by approximately one-half. (Consult Electromotive Systems.)
- 23) Sliding collector bars are not to be used between the drive and the motor. It must be hard wired (i.e. festoon cable.)
- 24) Double collector shoes are required by CMAA spec 70 and 74.

** If there are any questions, or a further explanation of the above recommendations is needed, please contact Electromotive Systems at 800/288-8178 before proceeding.

** The above recommendations, if followed, will help to ensure troublefree start-up and successful operation of the adjustable frequency drive when applied to overhead material handling equipment.

IMPULSE•P³ External Resistor Specifications

Input Voltage	Hp	Model #	Traverse Resistor Part # Class A, B, C	Resistance	Traverse Resistor Part # Class D	*Resistance	Hoist W/Mechanical Load Brake Class A, B, C, D	Resistance
230 VAC	1	230AFD1-P3	EDB2003CT	110.0	EDB2005DTP	84.0	EDB2003CT	110.0
	2	230AFD2-P3	EDB2006CT	55.0	EDB2005DTP	44.0	EDB2003CT	110.0
	3	230AFD3-P3	EDB2009CT	37.5	EDB2011DTP	31.0	EDB2006CT	55.0
	5	230AFD5-P3	EDB2015CT	25.0	EDB2017DTP	20.0	EDB2009CT	37.5
460 VAC	1	460AFD1-P3	EDB4001CT	440.0	EDB4002DTP	354.0	EDB4001CT	440.0
	2	460AFD2-P3	EDB4003CT	230.0	EDB4004DTP	187.0	EDB4001CT	440.0
	3	460AFD3-P3	EDB4004CT	150.0	EDB4005DTP	133.0	EDB4003CT	230.0
	5	460AFD5-P3	EDB4007CT	100.0	EDB4008DTP	84.0	EDB4004CT	150.0

* If Electromotive Systems resistors are not used, this column should be used to determine the minimum ohmic values for dynamic braking resistors.

Service

This chapter includes information pertaining to on-call service, drive identification, troubleshooting, and warranty. Before you install, troubleshoot or service the drive, we highly recommend that you read this entire chapter. Doing this will help assure a quick response, minimize your on-site repair cost, and reduce crane downtime.

On-Call Service

If you ever require our assistance, contact us at 800/288-8178; our fax is 414/783-3508. Technical support is available 24 hours a day, seven days a week, and 365 days a year. If necessary, we can arrange to have a Service Technician visit your site to evaluate the situation.

Identifying Your Drive

If you ever have to contact Electromotive Systems about your drive, first determine the model and serial numbers of your drive by looking at the nameplate shown below.

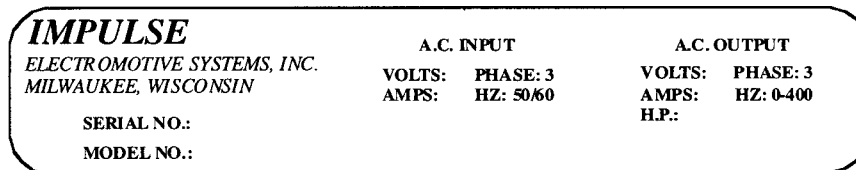

This nameplate is normally located on the side of the drive nearest to the keypad.

Service Policy

Should your IMPULSE•P³ drive fail during the warranty period, Electromotive Systems will repair or replace your unit within 72 hours (3 working days). In most cases we can supply a replacement unit within 24 hours (1 working day). If the problem is not covered under warranty, you are responsible for the cost of the repairs and the shipping charges.

To return a failed unit (or part):

1. Request a Return Authorization (RA) from Electromotive Systems' Service Department, as a condition for us to repair or replace the unit. Return the failed unit to Electromotive Systems **via prepaid freight**. When you call, please have the serial number of the drive available and be prepared to provide the information requested on the Return Authorization Information Sheet found on page 88.
2. A purchase order or credit card is required to cover the cost of the replacement unit or repairs to a returned unit.

Electromotive Systems will inspect the failed unit and determine if the unit is covered under warranty.

- If the unit is covered under warranty, Electromotive Systems will credit the cost of the replacement unit and/or repairs and reimburse freight charges.

Note: Freight charges incurred from sources other than common ground carriers WILL NOT be reimbursed unless pre-approved by Electromotive Systems.

- If the unit is not covered under warranty, Electromotive Systems will bill you for the cost of the replacement unit or the cost of repairs. Electromotive Systems will also bill you for a \$125.00 inspection fee (the fee will be waived if repairs are made to the unit) and any freight charges incurred by Electromotive Systems.

Electromotive Systems Limited Warranty

Electromotive Systems, Inc. hereafter referred to as Company, guarantees all work items manufactured by it against any defects of the material and/or workmanship for a period of two years from the date of shipment. Company makes NO OTHER WARRANTY, EXPRESSED OR IMPLIED, AS TO THE MERCHANTABILITY OR FITNESS OF THE ITEMS, THEIR INTENDED USE, OR AS TO THEIR PERFORMANCE. Any statement, description or specification in Company's literature is for the sole purpose of identification of items sold by the company and imparts no guarantee warranty or undertaking by company of any kind. Components and accessories not manufactured by Electromotive Systems are not included in this warranty and are warranted separately by their respective manufacturers.

Company's sole liability shall be to repair at its factory, or replace any item returned to it within two years from date of shipment, which Company finds to contain defective material or workmanship. All items to be repaired or replaced shall be shipped to Company (Note: return authorization by Company required) within said two year period, freight prepaid, as a condition to repair or replace defective material or workmanship. Company's herein assumed responsibility does not cover defects resulting from improper installation, maintenance or improper use. Any corrective maintenance performed by anyone other than the Company during the warranty period shall void the warranty. Company shall not be liable for economic loss, property damage, or other consequential damages or physical injury sustained by the purchaser or by any third party as a result of the use of any Company supplied items or material.

Company neither assumes nor authorizes any other person to assume for Company any other liability in connection with the sale or use of items sold by the Company.

Materials or items may not be returned for credit, without the prior written consent of the Company. Any authorized return of materials or items shall be subject to a restocking charge equal to 25% of the net invoiced amount (\$100 minimum charge for all control products) after Company determines that the material or item is in resalable condition. If upon receipt of the material or items cannot be resold without alteration or service, the Company reserves the right to reject the returned materials or items and to send the same back to said purchaser at purchaser's expense.

Any claim for errors in shipment or for material or time shortages must be received by Company within 30 days of shipment and must be accompanied by copies of the bill of lading and packing slip.

ELECTROMOTIVE SYSTEMS, INC.
RETURN AUTHORIZATION INFORMATION SHEET

To Expedite Processing Complete This Form

Please complete lines 5 through 15. If you have any questions regarding the completion of this form contact Electromotive Systems Service Department at 800-288-8178.

- 1. Return Authorization Number: RA _____ Issue Date / /
- 2. Customer _____
- 3. Customer P.O. Number _____
- 4. Contact Name _____ Phone _____ Fax _____
- 5. End User (name/location) _____
- 6. Component Model _____
- 7. Component Serial Number _____

ABOVE MATERIAL TO BE RETURNED VIA PRE-PAID FREIGHT TO:

*Electromotive Systems, Inc.
N49 W13650 Campbell Drive
Menomonee Falls, WI 53051*

Please enclose a copy of this form with material to be returned and mark RA number clearly on shipping container

APPLICATION INFORMATION

- 8. Type of application (i.e., Mill, Log Handling, Standard Industrial): _____
- 9. Crane Duty Cycle: CMAA A B C D E F (circle)
- 10. Motion: ___ Main Hoist ___ Aux Hoist ___ Bridge ___ Trolley
Other (please specify) _____
- 11. Describe conditions under which problem occurred _____
- 12. Make/Model Dynamic Braking Resistor: _____
- 13. Line Voltage ___ 230 ___ 460 ___ 575 ___ Other (specify) _____
- 14. Motor Information: Qty ___ 1 ___ 2 ___ Other (please specify) _____
_____ Motor RPM _____ Nameplate Full Load Amps
- 15. Reactors used ___ Line ___ Load ___ None

FOR WARRANTY INFORMATION SEE BACK OF THIS FORM

Control number 1584

Original Date: 04/08/97

Rev 00 Page 1 of 1

© 1999 ELECTROMOTIVE SYSTEMS, INC.

All rights reserved. The above notice applies to all copyrighted materials included within this product, including, but not limited to, this manual and the software embodied within this product. This manual is intended for the sole use of the person to whom it was provided, and any unauthorized distribution of the manual or dispersal of its contents is strictly forbidden. This manual may not be reproduced in whole or in part by any means whatsoever without the express written permission of Electromotive Systems, Inc..