



ELECTROMOTIVE SYSTEMS, INC.

IMPULSE[®]·VG+

FLUX VECTOR MOTOR CONTROLS

INSTRUCTION MANUAL

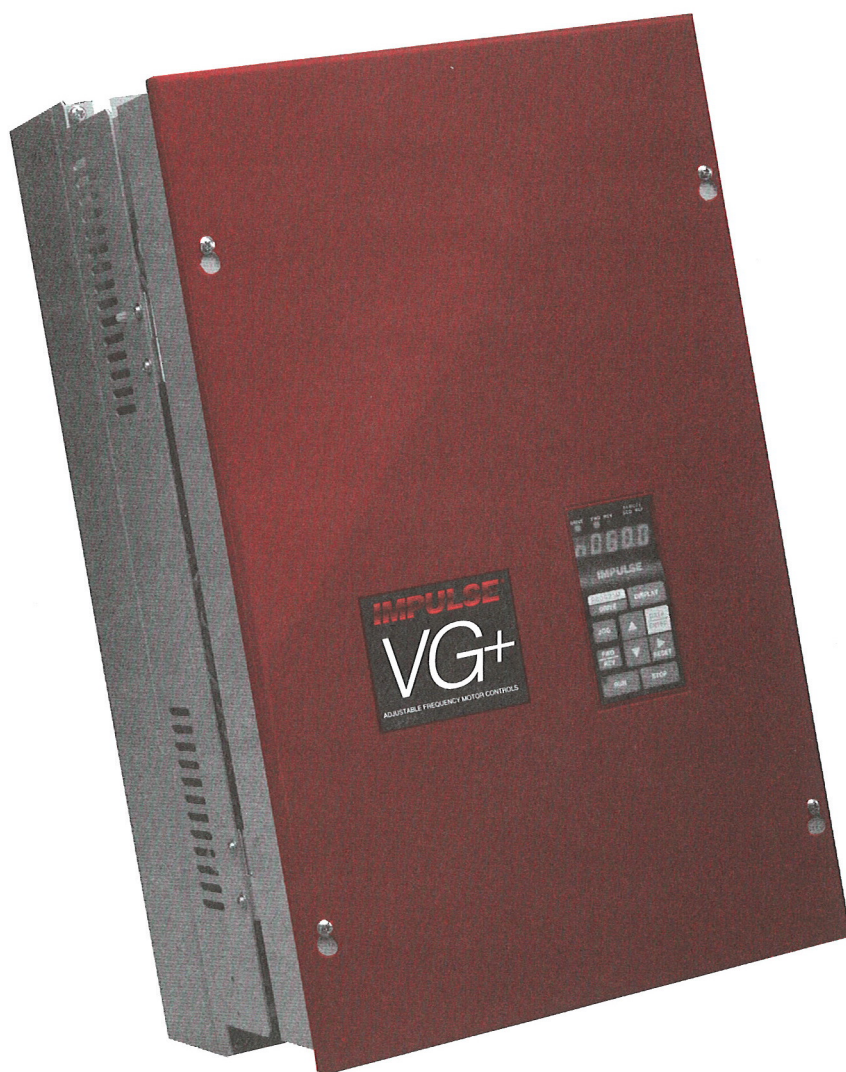

Table of Contents

Forward.....	1
Section 1: Introduction	2
1.1 General	2
1.2 Receiving	3
1.3 Verify Model Number on Ratings Sticker	3
Section 2: Installation	4
2.1 Location	4
2.2 Positioning	4
2.3 IMPULSE•VG+ Dimensions - 230V	5
2.4 IMPULSE•VG+ Dimensions - 460V	6
2.5 CDBR Braking Unit Dimensions	8
2.6 230V IMPULSE•VG+ Specifications	9
2.7 460V IMPULSE•VG+ Specifications	10
2.8 CDBR Braking Module Specifications.....	11
Section 3: Wiring	12
3.1 Main Power Wiring	13
3.1.1 Main Circuit Input/Output Considerations.....	13
3.1.2 Power Wiring Diagram	14
3.1.3 Grounding Considerations.....	15
3.1.4 Suggested Input Fuse, Circuit Breaker and Wire Sizing	16
3.1.5 Line Voltage Selection for IMPULSE•VG+ Logic Power Supply	18
3.2 Dynamic Braking Module (CDBR)	19
3.2.1 Dynamic Braking Module (CDBR) Wiring Precautions	19
3.2.2 DB Module Wiring as a Function of Drive Rating	20
3.2.3 Line Voltage Selection for CDBR Braking Units	22

Table of Contents

3.3 Encoder Wiring	23
3.3.1 Encoder Wiring Precautions	23
3.3.2 Encoder Connection Diagrams	24
3.4 Control Circuit Wiring	26
3.4.1 Control Circuit Wiring Precautions	26
3.4.2 Control Input Terminal Functions	27
3.4.2 Control Input Terminal Functions (Continued)	28
3.5 Control Output Terminal Wiring	30
3.5.1 Control Output Terminal Wiring Precautions	31
3.5.2 Control Output Wiring - Interconnection Diagram	31
Section 4: IMPULSE•VG+ Programming Summary	32
4.1 Basic Programming	32
4.2 Keypad Lockout	33
4.3 Speed Control Method	33
4.4 Stopping Method	34
4.5 Selecting Speeds	34
4.6 Acceleration/Deceleration	34
4.7 IMPULSE•VG+ Special Features	35
4.7.1 Micro-Positioning Control	35
4.7.2 Automatic Load Float	35
4.7.3 Quick Stop	35
4.7.4 Reverse Plug Simulation	36
4.7.5 Slack Cable Detection	36
4.7.6 Ultra-Lift	36
4.7.7 Alternate Torque Limit	37
4.7.8 Nfb is Positive/Nfb is Negative	37
4.7.9 Torque Limit Acceleration/Deceleration Function	37
4.7.10 Upper Limit Functions	38
4.7.11 Lower Limit Functions	38

Section 5: Digital Keypad	39
5.1 Operator Layout and Key Functions	39
5.2 Programming Mode Key Functions	40
5.3 Changing Constant Data in Program Mode	42
5.4 Local Operator Control Mode Key Functions	43
Section 6: To Begin Programming.....	45
6.1 What is a Constant?	45
6.1.1 Access to Various Constants	45
6.2 Multi-Step Speed Reference Constants (An Constants)	46
6.3 Active Mode (Bn) Constants	47
6.4 System Mode (Sn) Constants	48
6.5 CONTROL (Cn) Constants	61
6.6 MOTOR (Dn) Constants	63
6.7 MONITOR (Un) Constants	64
6.8 Order (On) Constants	68
Section 7: Start-Up	70
7.1 Power Off Checks	70
7.2 Initial Power Up	71
7.3 Factory Default Settings	71
7.4 Which Way is Up?	72
7.4.1 Rotation Check Procedure	72
7.4.1 Rotation Check Flow Chart	73
7.5 Setting the Speed Control Method	75
7.5.1 Speed Control Mode Selection Flow Chart	75
7.6 Setting the Speeds in Multi-Step Method	76
7.7 Infinitely Variable Mode/Analog Input: Upper and Lower Limit	76
7.8 Infinitely Variable Mode/Digital Input: Upper and Lower Limit	77
7.9 Test Run on the Hoist	78

Table of Contents

Section 8: Traverse Applications	80
8.1 Single Motor Horizontal Applications (Trolley and Bridge)	80
8.1.1 Program Changes for Traverse Motions (Single Motor Only)	81
8.1.1.1 Traverse Application Multi-Step Operation Table	81
8.1.2 Traverse Application Control Section Connections	82
8.2 Dual Motor Traverse Applications (Load Sharing)	84
8.2.1 Program Changes for Dual Motor Traverse Applications	84
8.2.2 Dual Motor Application Control Section Connections	85
Section 9: Special Features	86
9.1 Standard Safety Functions	86
9.1.1 STOP Key (of Digital Operator) Operation	86
9.1.2 RUN Button Operation	87
9.1.3 Phase Loss Detection	88
9.1.4 Fault Annunciation by PHC output	88
9.2 The Basic Hoisting Sequences	89
9.2.1 Normal Operation Start Sequence (Brake Proving Type)	90
9.2.2 Start Sequence When Upper Limit is Input	91
9.2.3 Normal Operation Stop Sequence (Brake Proving Type)	92
9.3 Micro-Positioning Control	93
9.4 Load Float (Zero Speed)	94
9.5 Quick Stop Function	95
9.6 Reverse Plug Simulation Function	96
9.7 Automatic Keypad Lockout (Sn-03 functions)	97
9.8 Ultra-Lift	98
9.9 Alternate Torque Limit Gain (Cn-29 Function)	99
9.10 Slack Cable Detection	100
9.11 Speed Feedback (Nfb) Nfb is Positive/Nfb is Negative	101
9.12 Upper and Lower Limit Functions	102
9.13 Torque Limit Acceleration/Deceleration Function	104

Section 10: Troubleshooting 105

- 10.1 Periodic Inspection 105
- 10.2 Troubleshooting 105
 - 10.2.1 Motor/Drive Won't Run 106
 - 10.2.2 Motor Stalls or Won't Accelerate Properly 107
 - 10.2.3 Motor Hunting or Vibration (Instability) 108
 - 10.2.4 Fault Trip Condition 109
- 10.3 Corrective Action at Specific Faults 115
- 10.4 Corrective Action for Miscellaneous Problems 117
- 10.5 Power Section Check 118

Appendix I: Recommended Wiring 117

Appendix II: Spare Parts List 122

Thank You!

We at Electromotive Systems, Inc. appreciate your purchase of this IMPULSE•VG+ adjustable frequency drive. When properly installed, operated and maintained, the IMPULSE•VG+ will provide a lifetime of reliable, trouble free operation. It is MANDATORY that the person who operates, inspects, and maintains this equipment thoroughly read and understand this manual.

This manual has been designed to serve as a self-supporting guide for the proper installation, operation, and maintenance of the IMPULSE•VG+ adjustable frequency drive. In it, you'll find step-by-step instructions covering topics ranging from installation to preventative maintenance and troubleshooting. If you require additional assistance, please feel free to contact either your local supplier or Electromotive Systems by phone at 414/783-3500 or by fax 414/783-3510.

Warning!

- Do not touch any circuit components while the main, AC power is on. In addition, you must wait until the red "Charge" lamp is extinguished before performing any service on the unit. It may take as long as 10 minutes for the charge on the main DC bus capacitors to drop to a safe level. Failure to adhere to this warning could result in serious injury.
- Do not check signals during operation.
- Be sure to ground the IMPULSE•VG+ unit using the G (E) terminal.
- Never connect the main output terminals (T1, T2, T3) to the incoming three-phase AC source (L1, L2, L3). This will damage the unit!

© 1994 ELECTROMOTIVE SYSTEMS, INC.

All rights reserved. The above notice applies to all copyrighted materials included with this product, including, but not limited to, this manual and the software embodied within the product. This manual is intended for the sole use of the person to whom it was provided, and any unauthorized distribution of the manual or dispersal of its contents is strictly forbidden. This manual may not be reproduced in whole or in part by any means whatsoever without the expressed written permission of ELECTROMOTIVE SYSTEMS, INC.

Section 1: Introduction

1.1 General

The IMPULSE•VG+ represents a new age in adjustable speed motor controls. The IMPULSE•VG+ goes far beyond prior VFD designs by adopting true torque control capabilities. The IMPULSE•VG+ uses insulated gate bipolar transistors (IGBT), a 16 bit microprocessor and Texas Instrument's newest digital signal processor (DSP) to provide unsurpassed operability and safety to crane and hoist applications.

The IMPULSE•VG+ incorporates a high performance, pulse width modulated (PWM) design generating the optimum current waveform to produce any desired speed and torque from a conventional AC motor.

The IMPULSE•VG+ is a unique hardware and software configuration specifically designed to meet the severe demands of cranes and hoists. This product is the direct result of experience in applying adjustable frequency drives to satisfy the demanding requirements of this market. Listed below are a few of the key features:

- Easily configured for conventional pendant or joystick control.
- Can be directly interfaced with 120VAC control signals.
- User selected speed control methods--multi-step (up to 9) or infinitely variable speed (by analog joystick or pendant).
- Brake Proving at Start and Stop.
- Ultra-Lift™ for high speed operation of lighter loads.
- Micro Positioning Control™ for precise position or spotting of the load.
- Load Float™ (servo control of position).
- Slack Cable detection for operation of bucket hoists.
- Alternate Torque Limit for load testing.
- Upper and Lower Limit Input and special functionality.
- Fault annunciation for safety and reliability.

1.2 Receiving

This unit has been put through demanding tests at the factory prior to shipment. Before unpacking please check the following.

- Read the specifications sticker on outside of box. Compare the description on that sticker with the description of the product on your purchase order.
- Inspect for damage sustained in transit. Damage to carton may indicate unit damage.

After unpacking, please check the following:

- Check to see that the specifications sticker (shipped loose) with the unit matches your application requirement (i.e. current and voltage).
- Check to see that all electrical connections and screws are secure.
- Verify that there is no visible damage to any of the components.

If any part of the IMPULSE•VG+ is damaged or lost, immediately notify both the carrier and Electromotive Systems.

1.3 Verify Model Number on Ratings Sticker

Before you mount the unit, you should first verify the voltage, current and horsepower ratings on the ratings label to ensure that it matches with your application requirements.

The model numbering system is shown below:

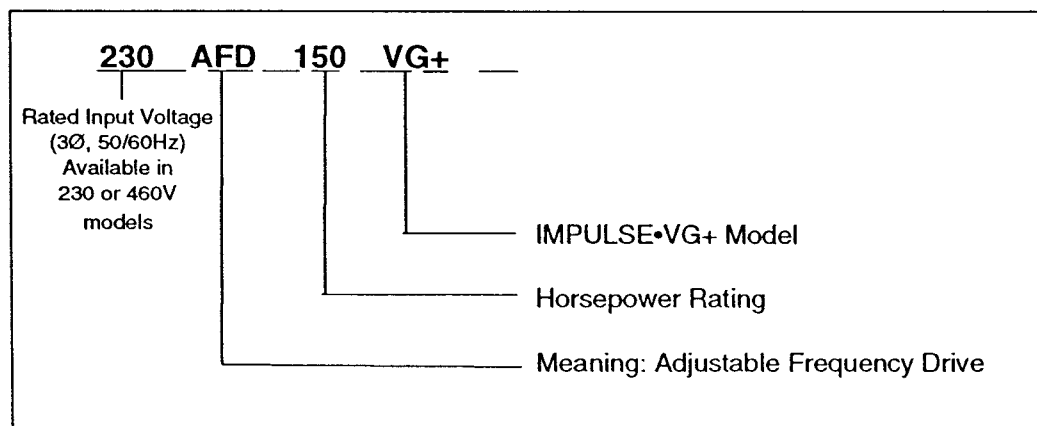

Section 2: Installation

Special Note: If you purchased this IMPULSE•VG+ as part of an Electromotive Systems pre-engineered, *TCONTROLS*® motor control panel you should skip Sections 2 and 3 and proceed directly to Section 4.

2.1 Location

The selection of the proper mounting location of the IMPULSE•VG+ is imperative to achieve optimum performance and a normal operating life. These units should always be installed in areas where the following conditions exist:

- Ambient operating temperature is: +14 to + 122 °F (open chassis) or +14 to 104 °F (for NEMA 1).
- Protected from rain and moisture.
- Protected from corrosive gases or liquids.
- Sheltered from direct sunlight.
- Free from metallic particles or excessive airborne dust.
- Free from excessive vibration (see specifications).

2.2 Positioning

Make sure there is sufficient clearance around the IMPULSE•VG+ for cooling and maintenance purposes (see below). To maximize effective air flow and cooling, the IMPULSE•VG+ should be installed with its heatsink fins oriented vertically.

Your installation should adhere to the following recommended minimum clearances.

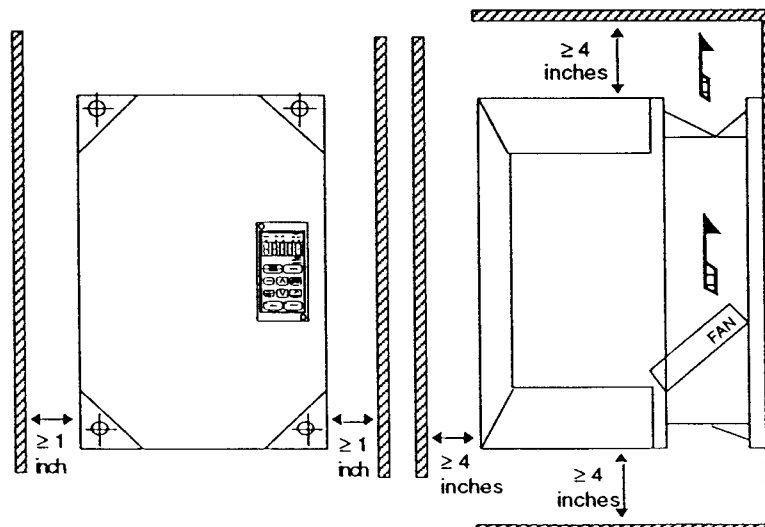

2.3 IMPULSE•VG+ Dimensions - 230V

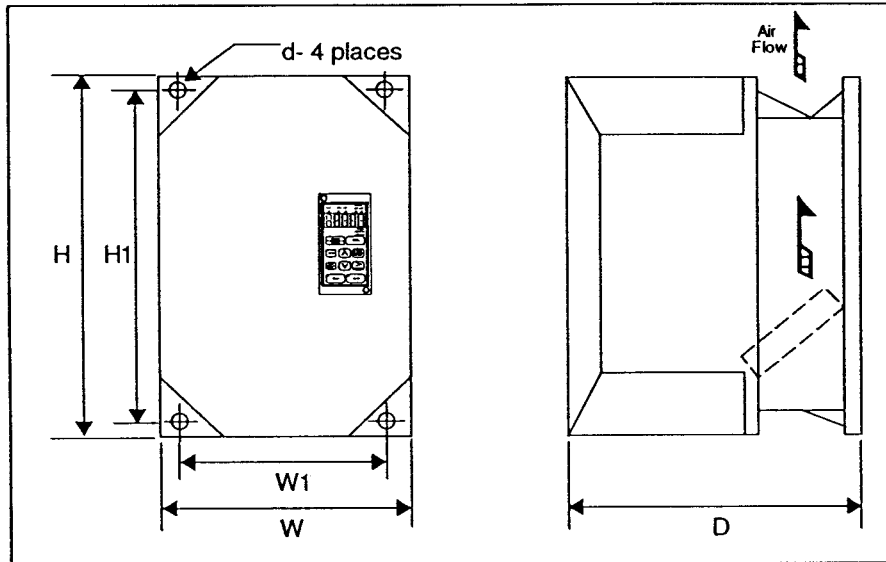

Model Number	Hp Rating	Dimensions in inches (mm)						Wt. in lbs. (KG)				
		Overall			Mounting							
		W	H	D	W1	H1	d					
230AFD1-VG+	1	8.05 (204.5)	11.97 (304)	7.48 (190)	7.09 (180)	11.22 (285)	.236 M6	11 (5)				
230AFD3-VG+	3		8.86 (225)	10.04 (255)				7.87 (200)	13.19 (335)	15 (7)		
230AFD5-VG+	5		13.94 (354)							10.83 (275)	19.09 (485)	22 (10)
230AFD7.5-VG+	7.5		19.69 (500)									21.06 (535)
230AFD10-VG+	10		9.84 (250)	10.04 (255)				14.76 (375)	49.02 (1245)	60 (27)		
230AFD15-VG+	15	12.80 (325)	11.02 (280)	21.65 (550)	71 (32)	71 (32)						
230AFD20-VG+	20	18.70 (475)	17.82 (453)			.393 M10		337 (153)	130 (59)			
230AFD30-VG+	30	31.50 (800)	23.62 (600)	.472 M12	143 (65)				143 (65)			
230AFD50-VG+	50	50.39 (1280)							337 (153)			
230AFD75-VG+	75											
230AFD100-VG+	100											

2.4 IMPULSE•VG+ Dimensions - 460V

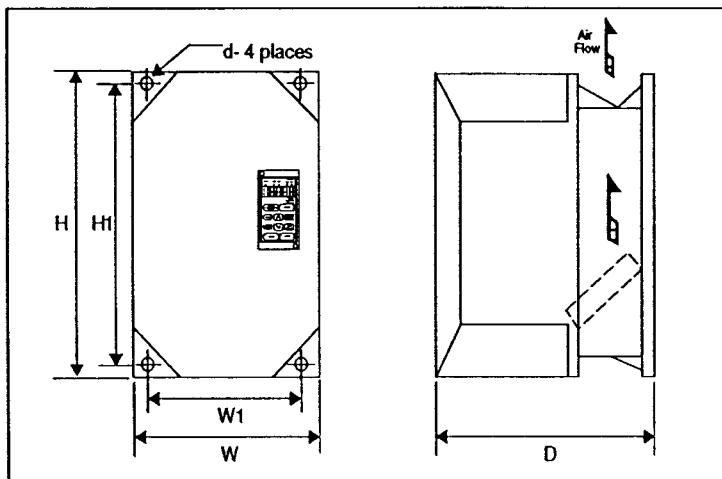

Model Number	Hp Rating	Dimensions in inches (mm)					d	Wt. in lbs. (KG)
		Overall						
		W	H	D	W1	H1		
460AFD1-VG+	1			8.66			.236 M6	20 (9)
460AFD3-VG+	3	8.05 (204.5)	13.94 (354)	(220)	7.09 (180)	13.19 (335)		22 (10)
460AFD5-VG+	5							
460AFD10-VG+	10							
460AFD15-VG+	15	9.84 (250)	19.69 (500)	10.04 (255)	7.87 (200)	19.09 (485)	.314 M8	49 (22)
460AFD20-VG+	20	12.80 (325)	21.65 (550)		10.83 (275)	21.06 (535)		71 (32)
460AFD30-VG+	30							
460AFD40-VG+	40	13.78 (350)	28.54 (725)	11.02 (280)	9.84 (250)	27.76 (705)	.393 M10	93 (42)
460AFD60-VG+	60				18.70 (475)	35.43 (900)		229 (104)
460AFD75-VG+	75							
460AFD100-VG+	100	22.64 (575)	36.42 (925)	12.99 (330)	21.65 (550)	52.17 (1325)	.472 M12	203 (92)
460AFD150-VG+	150							37.40 (950)
460AFD200-VG+	200	37.97 (960)	62.99 (1600)	17.91 (455)	61.02 (1550)	793 (360)		
460AFD250-VG+	250						37.97 (960)	62.99 (1600)
460AFD300-VG+	300	37.97 (960)	62.99 (1600)	17.91 (455)	61.02 (1550)	925 (400)		
460AFD400-VG+	400							

† refer to the figure on the next page for the locations of the mounting holes.

2.4 IMPULSE•VG+ Dimensions - 460V (Continued)

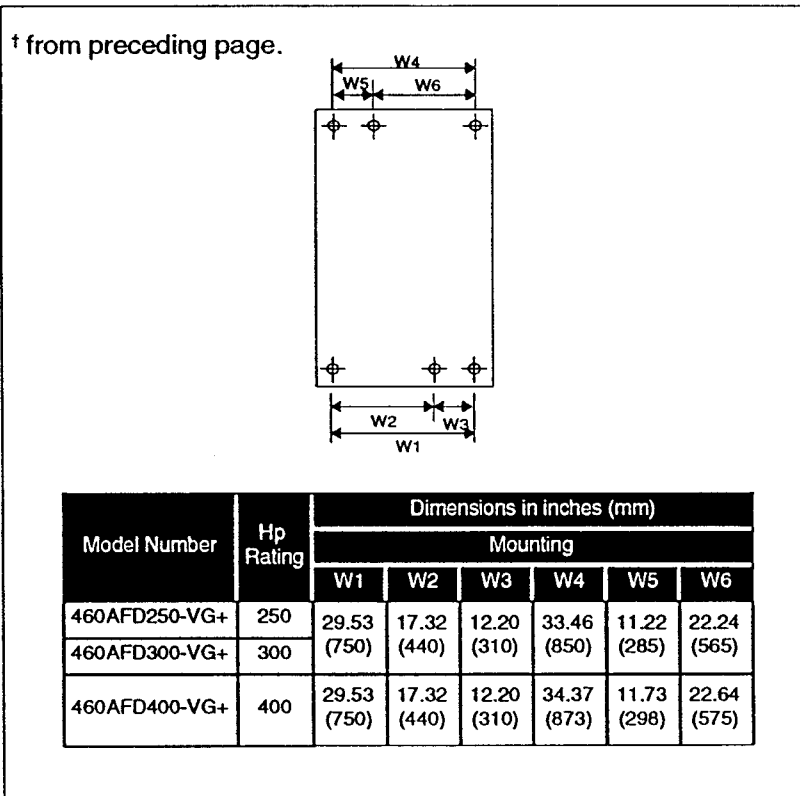

2.5 CDBR Braking Unit Dimensions

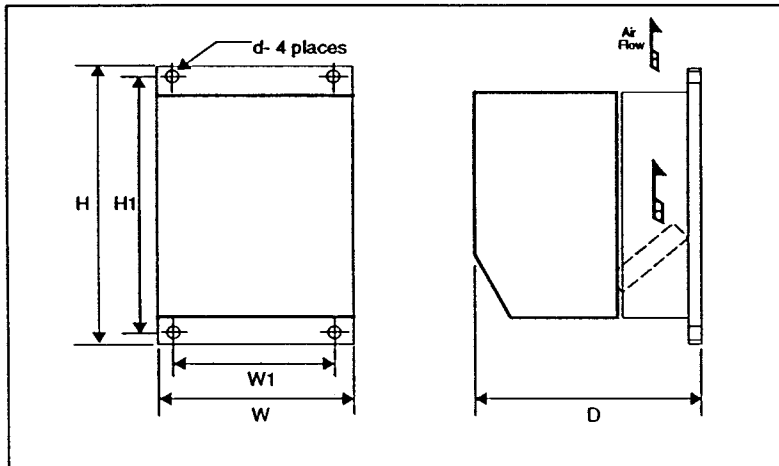

Model Number	Hp Rating	Dimensions in inches (mm)						Wt. in lbs. (kg.)
		Overall			Mounting			
		W	H	D	W1	H1	d	
CDBR-2110	60	7.09 (180)	14.57 (370)	7.87 (200)	5.51 (140)	13.78 (350)	.24 (6)	10 (4.54)
CDBR-2022	15	5.51 (140)	11.02 (280)	6.29 (160)	3.94 (100)	10.23 (260)		7.13 (3.24)
CDBR-4045	30							7.79 (3.54)
CDBR-4090	50	8.66 (220)	14.76 (375)	7.87 (200)	7.09 (180)	13.98 (355)		12 (5.45)
CDBR-4220	150	9.84 (250)	14.76 (375)	7.87 (200)	8.27 (210)	13.98 (355)		27.19 (12.34)

2.6 230V IMPULSE•VG+ Specifications

Model Number	230AFD(Hp)-VG+										
Inverter Rating (Hp)	1	3	5	7.5	10	15	20	30	50	75	100
Inverter Rating (kW)	0.7	2.2	3.7	5.5	7.5	11	15	22	37	55	75
Rated Current (A)	4.8	9.6	16	24	32	48	64	96	160	224	300
Max. Continuous Current (A)	5.4	11	18	27	36	54	72	108	180	252	337
Rated Input Power Supply Voltage & Frequency	3-phase, 200, 208, 220, or 230 VAC; 50 or 60 Hz										
Allowable Input Voltage Fluctuation	± 10% of nominal										
Allowable Input Frequency Fluctuation	± 5% of nominal										
Control Method	Fully digital vector control, sine wave PWM										
Max. Voltage (VAC) Output	3-phase, 200, 208, 220, or 230 VAC (maximum depends upon input supply)										
Rated Speed	Up to twice (Ultra-Lift function) motor nameplate RPM										
Output Speed Control Range	1000 to 1, plus zero servo function										
Output Speed Precision	0.01% (with digital reference command, -10 to +40°C); 0.1% (with analog reference command, 25 °C ± 10°C)										
Speed Ref. Resolution	0.01 % (by digital operator); 0.1% by analog ref (10bits/10V); 0.03% by AI-14U (14 bits/10V)										
Output Speed Resolution	0.01 % (1/30,000)										
Overload Capacity	150% of rated for 1 minute; 130% of max. continuous for 1 minute										
Remote Speed Ref. Sources	0- 10 VDC (20 kΩ); 4- 20 mA (250 Ω); ± 10 VDC (optional); Serial (optional)										
Accel/ Decel Times	0.1 to 3,000 secs.; two sets; each parameter (4 total) is independently adjustable										
Braking Torque	Approx. 20 % (if motor and inverter are sized 1:1); 150% or more is optional with dynamic braking										
Motor Overload Protection	Electronic, frequency dependent, overload relay (field-programmable) or by thermistor feedback										
Overcurrent Protection Level	200% of rated current										
Blown Fuse Protection	Yes										
Overvoltage Protection Level	400 VDC										
Undervoltage Protection Level	210 VDC										
Power Loss Ride-thru	Minimum time is 15 mS, maximum time is 2 seconds										
Heatsink Overtemperature	Thermostat trips at 90 °C (in addition, model 230AFD50-VG+ and above also have fan loss detection)										
Torque Limit Selection	Separate functions for forward, reverse, regenerative (all selectable from 0 - 300%)										
Ground Fault Protection	Yes										
Other Protection Functions	Speed deviation, overspeed, mechanical brake failure, lost output phase, failed oscillator, PG disconnect										
DC Bus Voltage Indication	Yes, charge LED is on until DC bus voltage drops below 50 VDC										
Location	Indoors, protected from moisture, corrosive gases and liquids										
Ambient Operating Temp.	14- 104 °F (-10- +40°C) for NEMA 1 type; 14- 122 °F (-10 - +50 °C) for open chassis type										
Storage Temperature	-4 - 140 °F (-20 - +60 °C)										
Humidity	90% relative, non-condensing										
Vibration	1 G less than 20 Hz, 0.2 G from 20-50 Hz										

2.7 460V IMPULSE•VG+ Specifications

Model Number	460AFD(Hp)-VG+															
Inverter Rating (Hp)	1	3	5	10	15	20	30	40	60	75	100	150	200	250	300	400
Inverter Rating (kW)	0.7	2.2	3.7	7.5	11	15	22	30	45	55	75	110	160	185	220	300
Rated Current (A)	2.6	4.8	8.0	16	24	32	48	64	96	128	165	224	300	340	450	600
Max. Continuous Current (A)	2.9	5.4	9.0	18	27	36	54	72	108	144	180	252	337	380	506	675
Rated Input Power Supply Voltage & Frequency	3-phase, 380, 400, 415, 440, 460, or 480 VAC; 50 or 60 Hz															
Allowable Input Voltage Fluctuation	± 10% of nominal															
Allowable Input Frequency Fluctuation	± 5% of nominal															
Control Method	Fully digital vector control, sine wave PWM															
Max. Voltage (Vac) Output	3-phase, 380, 400, 415, 440, 460, or 480 VAC (maximum depends upon input supply)															
Rated Speed	Up to twice (Ultra-Lift function) motor nameplate RPM															
Output Speed Control Range	1000 to 1, plus zero servo function															
Output Speed Precision	0.01% (with digital reference command, -10 to +40°C); 0.1% (with analog reference command, 25°C ± 10°C)															
Speed Ref. Resolution	0.01 % (by digital operator); 0.1% by analog ref (10bits/10V); 0.03% by AI-14U (14 bits/10V)															
Output Speed Resolution	0.01 % (1/30,000)															
Overload Capacity	150% of rated for 1 minute; 130% of max. continuous for 1 minute															
Remote Speed Ref. Sources	0- 10 VDC (20 kΩ); 4- 20 mA (250 Ω); ± 10 VDC (optional); Serial (optional)															
Accel/ Decel Times	0.1 to 3,000 seconds; two sets; each parameter (4 total) is independently adjustable															
Braking Torque	Approx. 20 % (if motor and inverter are sized 1:1); 150% or more is optional with dynamic braking															
Motor Overload Protection	Electronic, frequency dependent, overload relay (field-programmable) or by thermistor feedback															
Overcurrent Protection Level	200% of rated current															
Blown Fuse Protection	Yes															
Overvoltage Protection Level	800 VDC															
Undervoltage Protection Level	420 VDC															
Power Loss Ride-Thru	Minimum time is 15 ms, maximum time is 2 seconds															
Heatsink Overtemperature	Thermostat trips at 90 °C (model 460AFD75-VG+ and above also have fan loss detection)															
Torque Limit Selection	Separate functions for forward, reverse, regenerative (all selectable from 0- 300%)															
Ground Fault Protection	Yes															
Other Protection Functions	Speed deviation, overspeed, mechanical brake failure, lost output phase, failed oscillator, PG disconnect															
DC Bus Voltage Indication	Yes, charge LED is on until DC bus voltage drops below 50 VDC															
Location	Indoors, protected from moisture, corrosive gases and liquids															
Ambient Operating Temp.	14- 104 °F (-10- +40°C) for NEMA 1 type; 14- 122 °F (-10 ~ +50 °C) for open chassis type															
Storage Temperature	-4 - 140 °F (-20 - +60 °C)															
Humidity	90% relative, non-condensing															
Vibration	1 G less than 20 Hz, 0.2 G from 20-50 Hz															

2.8 CDBR Braking Module Specifications

	230 Volts		460 Volts		
DB Module Model Number	CDBR-2022	CDBR-2110	CDBR-4045	CDBR-4090	CDBR-4220
Applicable Motor Output Hp	15	60	30	50	150
Max. Discharge Current (Peak A)	60	250	60	100	250
Rated Discharge Current (A)	20	80	18	30	80
Braking Start Voltage	330/345/365/380V \pm 3V		630/660/690/730/760V \pm 6V		
Max. Hysteresis Error	\approx 8V		\approx 16V		
VDC	243 to 400V		460 to 800V		
VAC	n/a	1 \emptyset , 200 ~ 230V, 50/60Hz	n/a	1 \emptyset , 380 ~ 480V, 50/60Hz	
Fin Overheat	Thermostat				
Power Charge Indication	Charge lamp stays ON until bus voltage drops below 50 VDC				
Location	Indoor (protected from corrosive gases and dust)				
Ambient Temperature	+14 to 140°F (-10 to 40°C) (no freezing)				
Storage Temperature	-4 to 140°F (-20 to 60°C)				
Humidity	90% RH (non-condensing)				
Vibration	1G less than 20Hz, up to 0.2G at 20 to 50Hz				
Protective Configuration	Wall-mounted enclosed type				

Section 3: Wiring

Special Note: If you purchased this IMPULSE•VG+ as part of an Electromotive Systems pre-engineered, T_{CONTROLS}® motor control panel you should skip Section 3 and proceed directly to Section 4.

The wiring of the IMPULSE•VG+ can be separated into several categories: power, encoder, control inputs and control outputs. The block diagram (below) should serve as a map to the appropriate section of this manual which explains the proper wiring of each unit. Following these sections in order will allow you to easily make the proper connections.

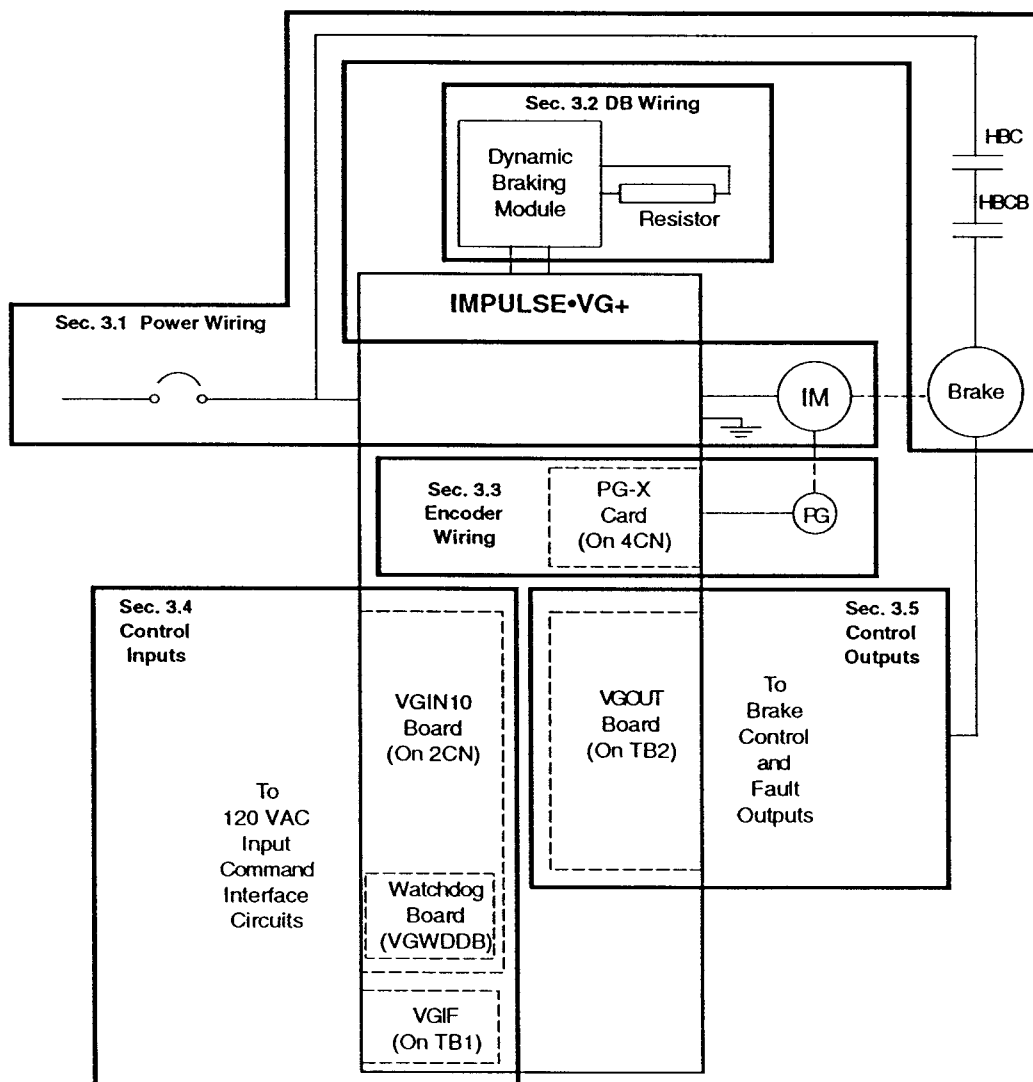

3.1 Main Power Wiring

The basic power wiring is illustrated in Section 3.1.2. Please remember to follow NEC guidelines when selecting the wire and branch circuit protection devices.

3.1.1 Main Circuit Input/Output Considerations

- The main input power on L1, L2, L3 is phase sequence insensitive (may be CW or CCW). Input sequence will not affect motor rotation direction.
- When the inverter output terminals (T1, T2, T3) are connected to motor terminals T1, T2, T3, respectively, the motor must rotate counterclockwise (viewed from opposite the shaft end) when a Forward Run command is given. (For hoisting applications, it is mandatory that Forward results in lifting (up direction).) **To reverse the direction of rotation, interchange any two motor leads. (You may also need to change the encoder wiring. Please see Section 3.3.) Note: Switching the input wiring to the inverter will not change the motor direction!**
- Never connect the incoming three-phase AC power to the inverter output terminals T1, T2, T3.
- There should be no contact between wiring leads and the IMPULSE•VG+ enclosure. A short-circuit could result.
- Never connect power factor correction capacitors on the inverter input or output.
- Never open or close inverter output contactors (between inverter and motor) unless the motor's inrush current (typically 500-600% of motor rated current) has been taken into consideration when the inverter model was selected.
- Redundant brake contactors (HBC and HBCB) are used to prevent an unsafe condition resulting from the potential failure of a single device.
- The thermistor leads, if used, must be separated from the power wiring and must use a shielded, twisted-pair cable (Belden 8760, or equivalent). Also, limit the maximum wiring distance to 330 feet (100 meters).

3.1.2 Power Wiring Diagram

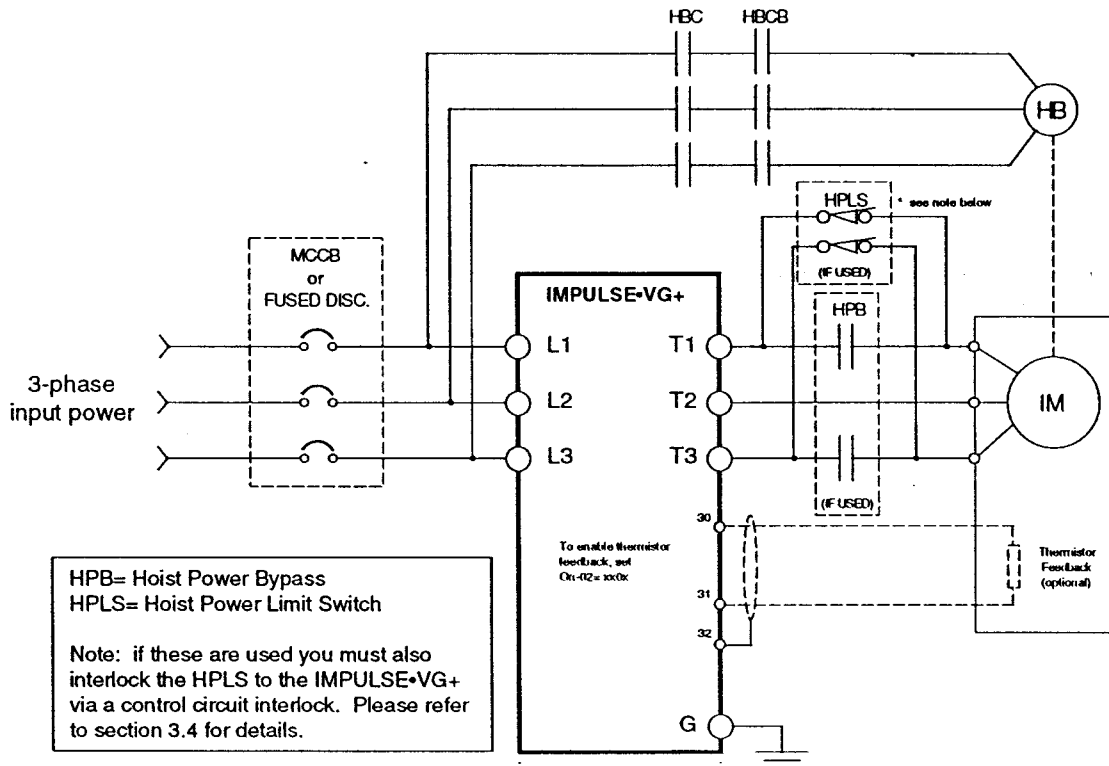

3.1.3 Grounding Considerations

Connect a positive ground using terminal E on the drive chassis or power terminal strip.

- Wire size should be selected according to the charts on the following pages. The lead length should also be kept as short as possible.
- Ground resistance should be 100 Ω or less.
- Never ground the IMPULSE•VG+ along with welding machines, large current machines, etc. Run the ground for the IMPULSE•VG+ in separate conduit.
- When several IMPULSE•VG+ units are used together they should all be directly grounded to a common ground pole. Alternatively, connecting all of the IMPULSE•VG+ Earth (E) ground terminals together and running a single wire to the ground pole is also acceptable. Be careful to ensure that you do not form a loop with the ground wires.



3.1.4 Suggested Input Fuse, Circuit Breaker and Wire Sizing

In order to comply with most safety standards you should have some disconnecting means and branch circuit protection between the incoming three-phase power supply and the IMPULSE•VG+. This branch circuit protection can either be in the form of a thermal, magnetic, molded case circuit breaker (MCCB) or dual element "slow blow" type fuses. The following tables provide the recommended ratings for each of the IMPULSE•VG+ models.

Caution: The following guidelines are only *suggested* values. You should always be sure to conform to your local electrical codes and wiring practices.

230 Volt Units:

Model Number	Rated Hp	Rated Current (CT)	Rated Current (A)		Wiring Size (AWG/MCM)			
			Input Fuse	Molded Case Circuit Breaker	Power Circuit Wiring	Control Wiring	Ground	
230AFD1-VG+	1	4.8	8	10	14- 10	16- 14	14- 10	
230AFD3-VG+	3	9.6	15	20	12- 10			
230AFD5-VG+	5	16	25	30				
230AFD7.5-VG+	7.5	24	30	50	10- 8			
230AFD10-VG+	10	32	40	60				
230AFD15-VG+	15	48	60	100	8- 6			
230AFD20-VG+	20	65	80		8- 4			
230AFD30-VG+	30	96	125	150	4- 1			
230AFD50-VG+	50	160	200	225	2- 4/0			4- 2
230AFD75-VG+	75	224	300	400				3- 2
230AFD100-VG+	100	300	400	600	4/0- MCM400			1- 2/0

3.1.4 Suggested Input Fuse, Circuit Breaker and Wire Sizing (Continued)

460 Volt Units:

Model Number	Rated Hp	Rated Current (CT)	Rated Current (A)		Wiring Size (AWG/MCM)		
			Input Fuse	Molded Case Circuit Breaker	Power Circuit Wiring	Control Wiring	Ground
460AFD1-VG+	1	2.6	4	5	14-10	16-14	14-10
460AFD3-VG+	3	4.8	8	10			
460AFD5-VG+	5	8.0	12	20			
460AFD10-VG+	10	16	25	30	12-10		10-2
460AFD15-VG+	15	24	30	50			
460AFD20-VG+	20	32	40	60	10-8		8-2
460AFD30-VG+	30	48	60	100	8-6		
460AFD40-VG+	40	64	80		150		4-1
460AFD60-VG+	60	96	125				
460AFD75-VG+	75	128	175	225	2-4/0		4-2
460AFD100-VG+	100	165	225	300			3-2
460AFD150-VG+	150	224	300	400			
460AFD200-VG+	200	300	400	600	4/0-MCM400	1-2/0	
460AFD250-VG+	250	340	450		800	MCM650 x 2	1/0-2/0
460AFD300-VG+	300	450	600	1000			MCM650 x 2
460AFD400-VG+	400	600	800				

3.1.5 Line Voltage Selection for IMPULSE•VG+ Logic Power Supply

The IMPULSE•VG+ logic power supply of some units is derived from a control transformer. (This applies to 460V units that are 15 Hp or higher). This transformer has multiple taps on its primary to accommodate different incoming line voltages. To select among the different primary windings, move the jumper plug on the small PC board as shown below. The initial setting is in the 460V position (shaded in the drawing below).

460 Volt IMPULSE•VG+ Units

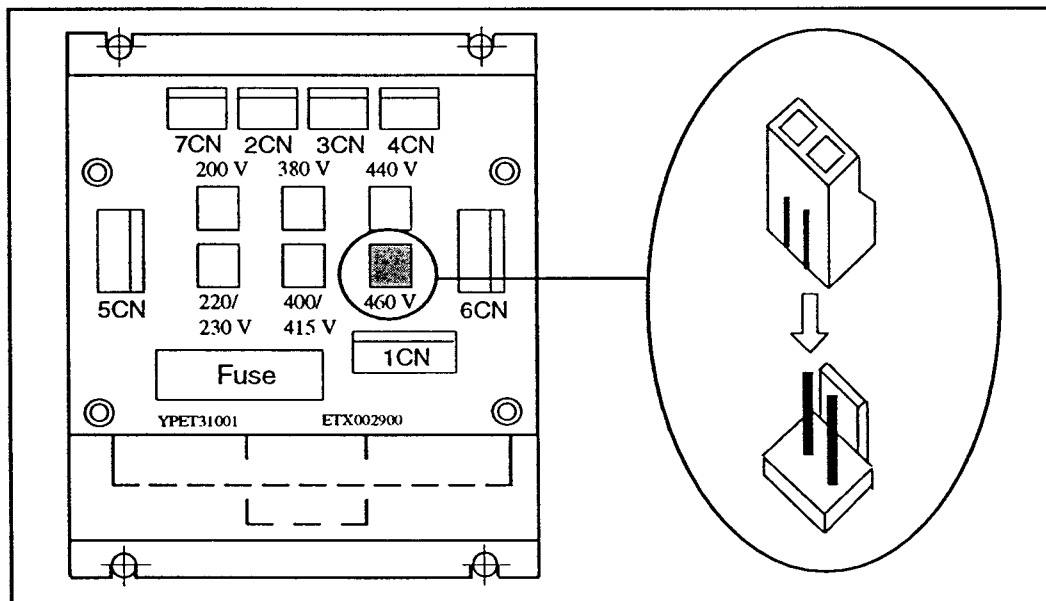

3.2 Dynamic Braking Module (CDBR)

The IMPULSE•VG+ flux vector control unit was designed specifically for hoisting applications. The dynamic braking circuit is an integral component of a hoisting system. Dynamic braking is used to dissipate the regenerative energy from the motor while lowering the load. As a result, the ratings of the DB components conform with the actual application requirements (HMI classification). This section gives the necessary wiring information corresponding to motor/drive Hp rating. When you are ready to wire the DB module, please refer to the appropriate diagram on the following pages.

3.2.1 Dynamic Braking Module (CDBR) Wiring Precautions

- Select the proper wire size in accordance with NEC requirements.
- Bring the wiring into the DB module through the holes in the bottom of the enclosure. Make a cross-cut in the rubber bushings supplied with the unit, then feed the wire through. This will provide the CDBR module components with an extra degree of protection from environmental contaminants.
- Separate the DB module power wiring from all control wiring.
- The wiring distance between the CDBR module and the IMPULSE•VG+ unit must be less than 16.4 feet (5 meters).
- The wiring distance between the braking resistor and the CDBR module/inverter must be less than 32.8 feet (10 meters).
- If your application demands exceed the capability of a single CDBR module, these units can be paralleled. (Consult Electromotive Systems applications engineers for more information). You can connect up to 10 of these units in a "master/slave" configuration. An application can have multiple slaves, but only one master. The individual CDBR modules are configured as either a master or slave with a small jumper plug found on the PC board. Wire the master/slave outputs as shown below with a twisted-pair, shielded cable (Belden 8760 or equivalent). Finally, connect all of the thermal switches (terminals 3 and 4) in parallel and interlock them with your run circuitry.

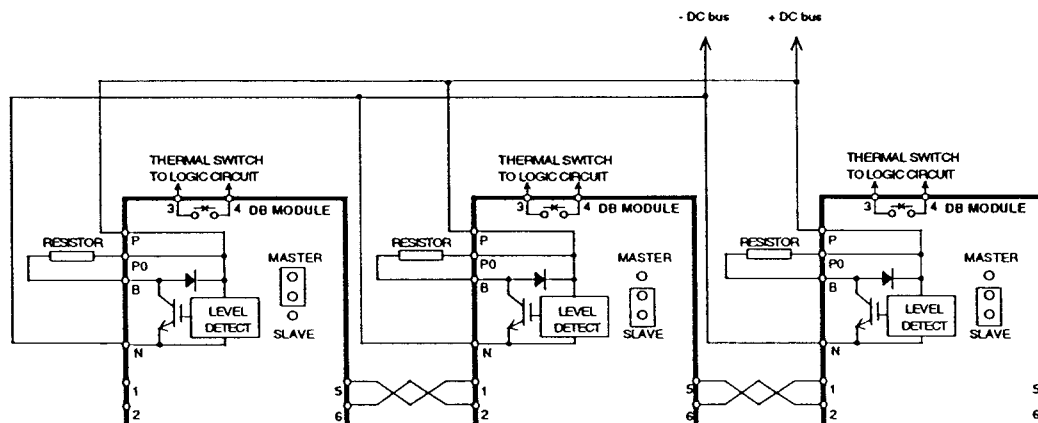

3.2.2 DB Module Wiring as a Function of Drive Rating

10 Hp and below (230 and 460 Volts):

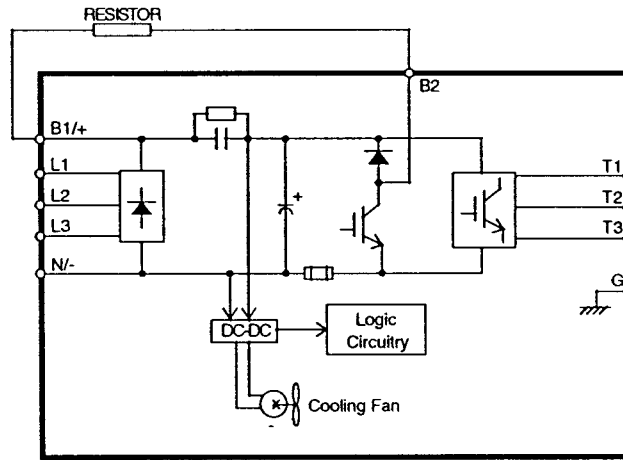

15 and 20 Hp (460 Volt);

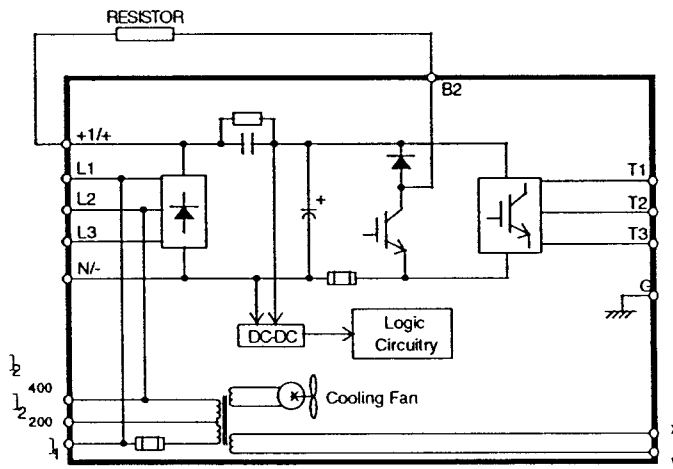

3.2.2 DB Module Wiring as a Function of Drive Rating (Continued)

15-100 Hp (230 Volt):

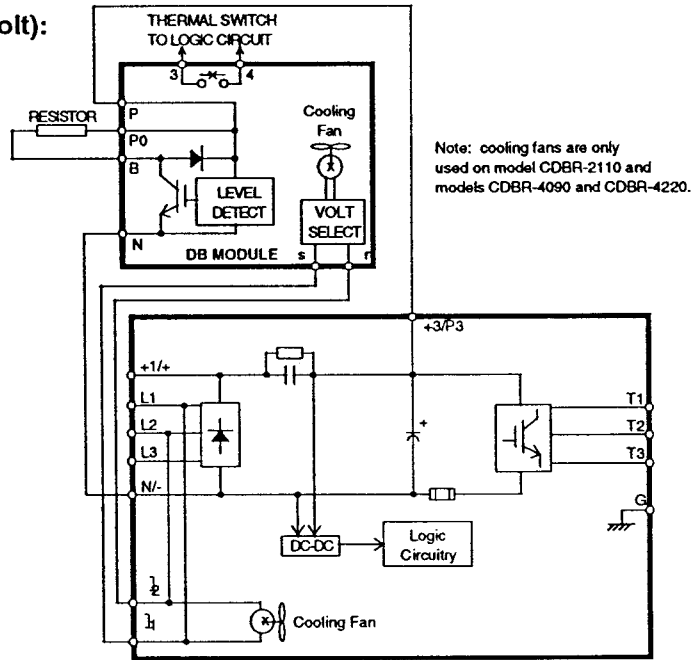

30-400 Hp (460 Volt):

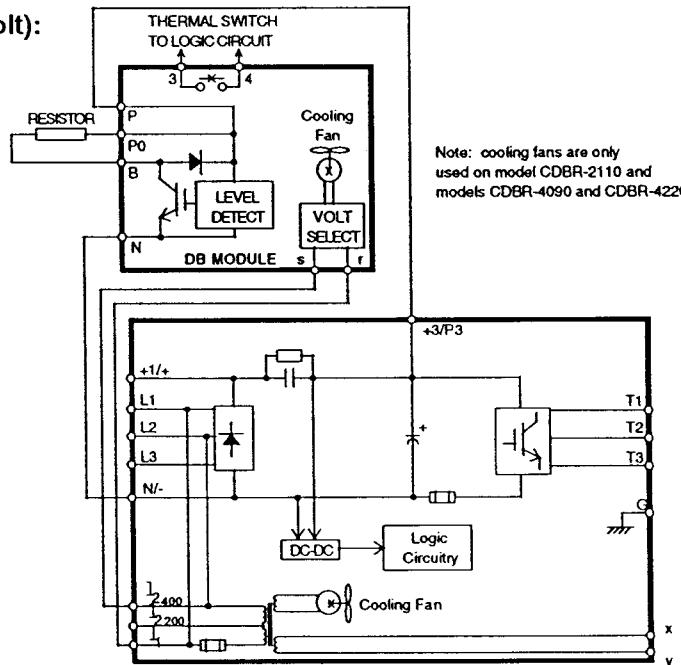

3.2.3 Line Voltage Selection for CDBR Braking Units

The CDBR braking units supplied with the drive must be set to correspond with the incoming power supply. This is achieved by changing the position of the CP1 shunt to the desired value. Select from the various CP1 shunt values on the small PC board as shown below. The initial setting is in the 230/460V position, depending upon the CDBR model number (shaded in the figure below).

200 Volt CDBR Units

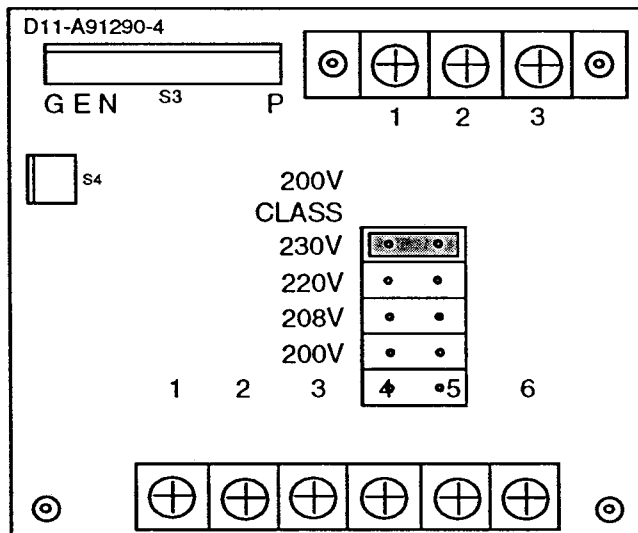

400 Volt CDBR Units

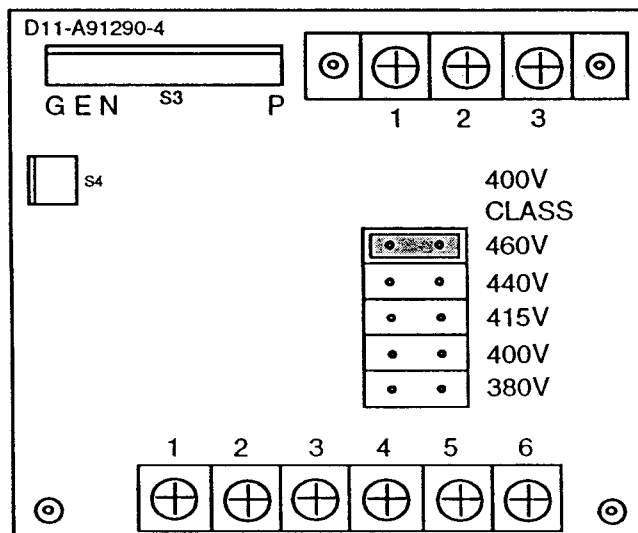

Note: the model CDBR-4220 also has a separate voltage selector board used to power the cooling fan. You must also verify the jumper on this board is set to correspond with the three-phase, AC input voltage. See diagram in Section 3.1.5 (460 Volt Class).

3.3 Encoder Wiring

The shaft-mounted encoder is used to provide speed and shaft position feedback to the IMPULSE•VG+ unit. Without this device, the flux vector control cannot operate properly. The encoder must conform to the following minimum specifications:

- + 12 VDC supply (if current demand is greater than 200 mA, an auxiliary power supply must be provided to drive the encoder).
- Quadrature (A and B channels, Z is not necessary).
- Line driver output circuit.
- Pulse per Revolution (PPR) count to give less than 300 KHz at maximum speed (1024 PPR is normal).
- The encoder must be direct coupled to the motor shaft via a zero backlash type coupling. Do not connect the encoder by using chain or pulley drives between the motor and encoder. And do not connect the encoder on the low speed shaft of a speed reducer.

3.3.1 Encoder Wiring Precautions

Encoder wiring precautions:

- Use a twisted-pair, shielded cable (Belden 9730, Brand Rex #T-11651 or equivalent).
- Keep the encoder wiring separate from power wiring (230, 460 or 120 VAC).
- Keep the wiring length less than 300 feet.
- Only ground the drive end of the shield as shown in the figure below.

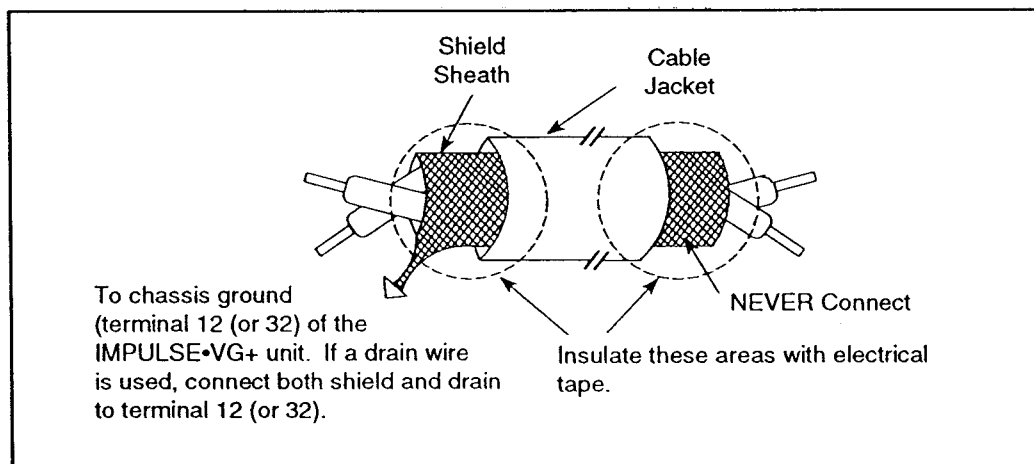

3.3.2 Encoder Connection Diagrams

The figure presented below illustrates the encoder feedback card (model number PG-X) along with a LakeShore model 8500 encoder. The following page also gives the required connection for a BEI E25 and a generic type encoder.

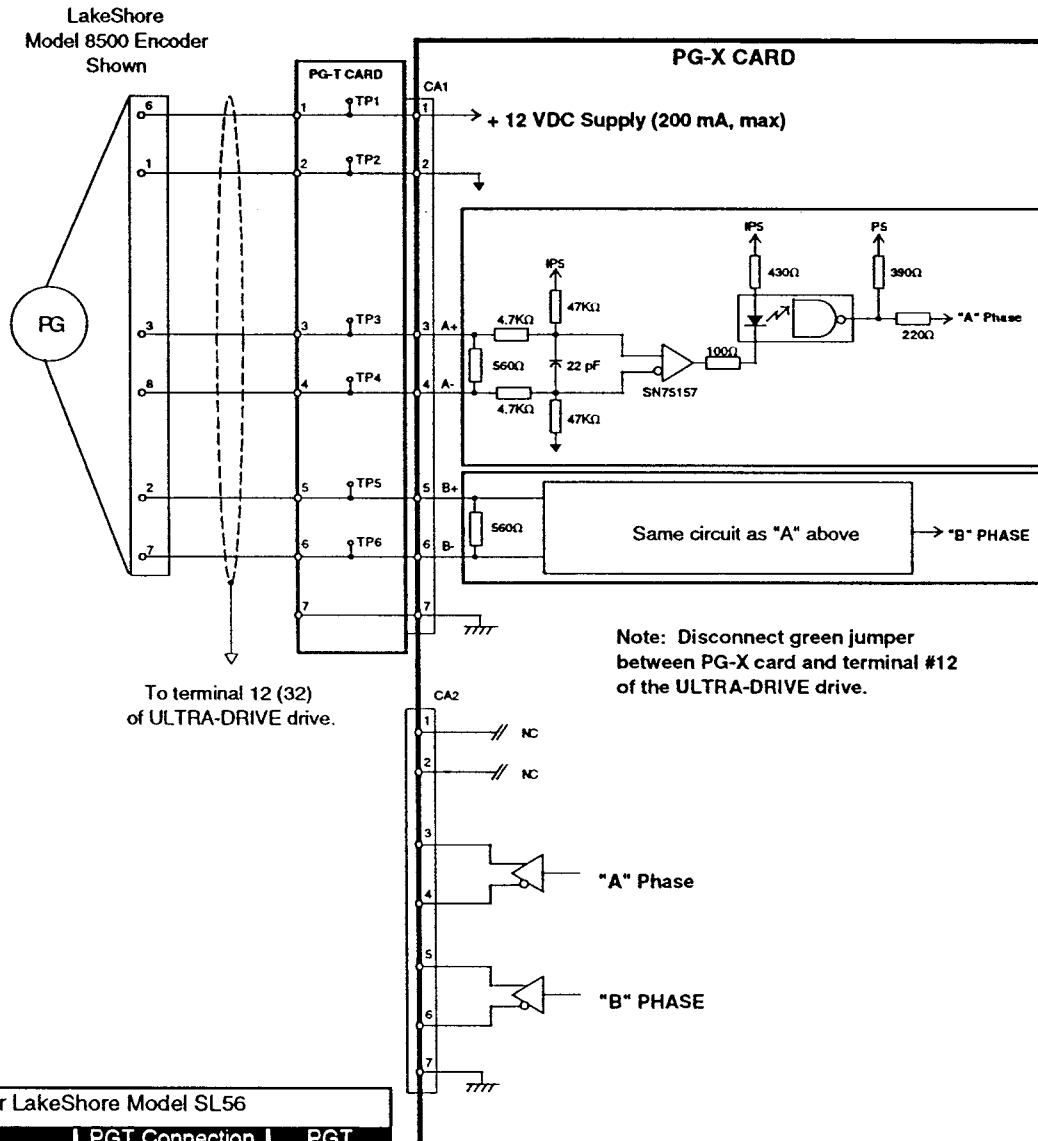

For LakeShore Model SL56			
Encoder Signal	Wire Color	PGT Connection Point (Terminal #)	PGT Test Point
+5 ~ 15VDC	Red	1	TP1
0V	Black	2	TP2
A+	Blue	3	TP3
A-	Gray	4	TP4
B+	Green	5	TP5
B-	Yellow	6	TP6

3.3.2 Encoder Connection Diagrams (Continued)

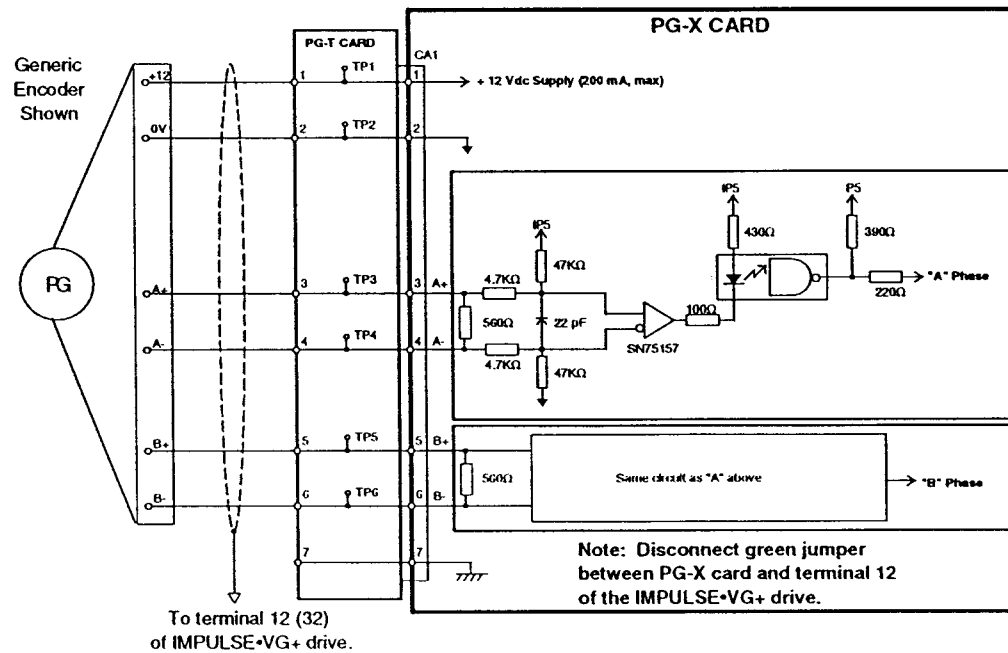
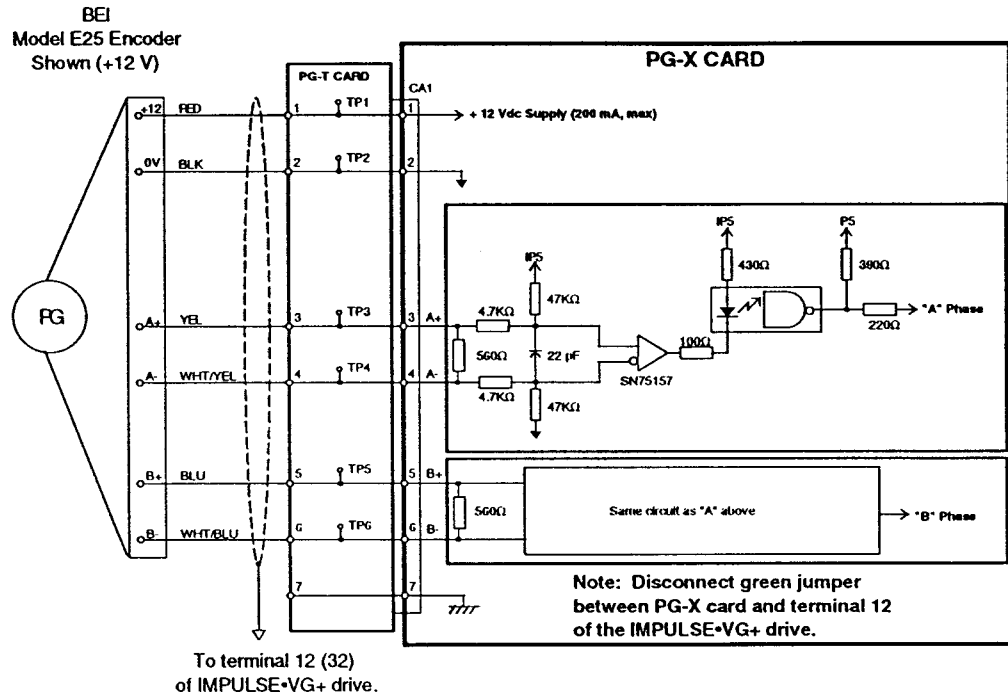

3.4 Control Circuit Wiring

The control circuit wiring of the IMPULSE•VG+ unit must be connected to a number of PC boards. Section 3.4.1 lists the general wiring precautions, and Section 3.4.2 provides a set of control input terminal tables, defining functions and signal levels. If you plan to deviate from the typical interconnect given in Section 3.4.2, this information will be a valuable reference.

3.4.1 Control Circuit Wiring Precautions

Wiring precautions:

- Be sure to double check your control circuit interconnections before you apply power to the unit.
- Wiring distance should be 164 feet (50 meters) or less.
- Control wiring must be separated from the three-phase power leads (L1, L2, L3, T1, T2, T3) to prevent capacitively coupled noise from entering the logic section.
- All 120 VAC control must be separated from the low level logic inputs. If wiring cannot be separated, it should always intersect the other control wiring at right angles.
- Always use R-C type surge absorbers (not MOV) type across the coils of any contactors installed in the inverter enclosure.
- For encoder and analog signals, or any other low level signal, use twisted shielded or twisted-pair shielded cable for control circuit interconnections. Be sure to only ground one end of the shield sheath as shown below:

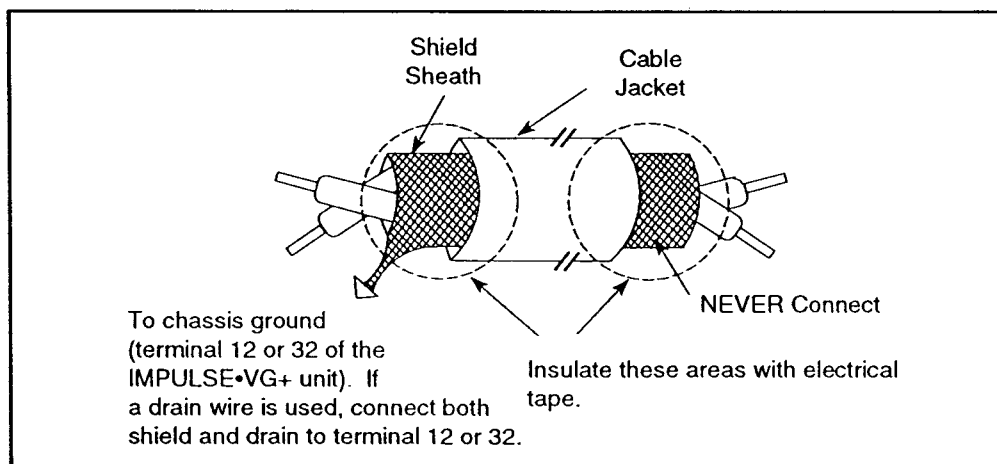

3.4.2 Control Input Terminal Functions

The wiring diagram given below shows a typical interconnect for five-speed control via our 120 VAC interface, the VGIF. It also shows the required connections for the upper and lower travel limit switches via the VGIN10 card. For a complete listing of terminal functions and specifications, please refer to the following tables.

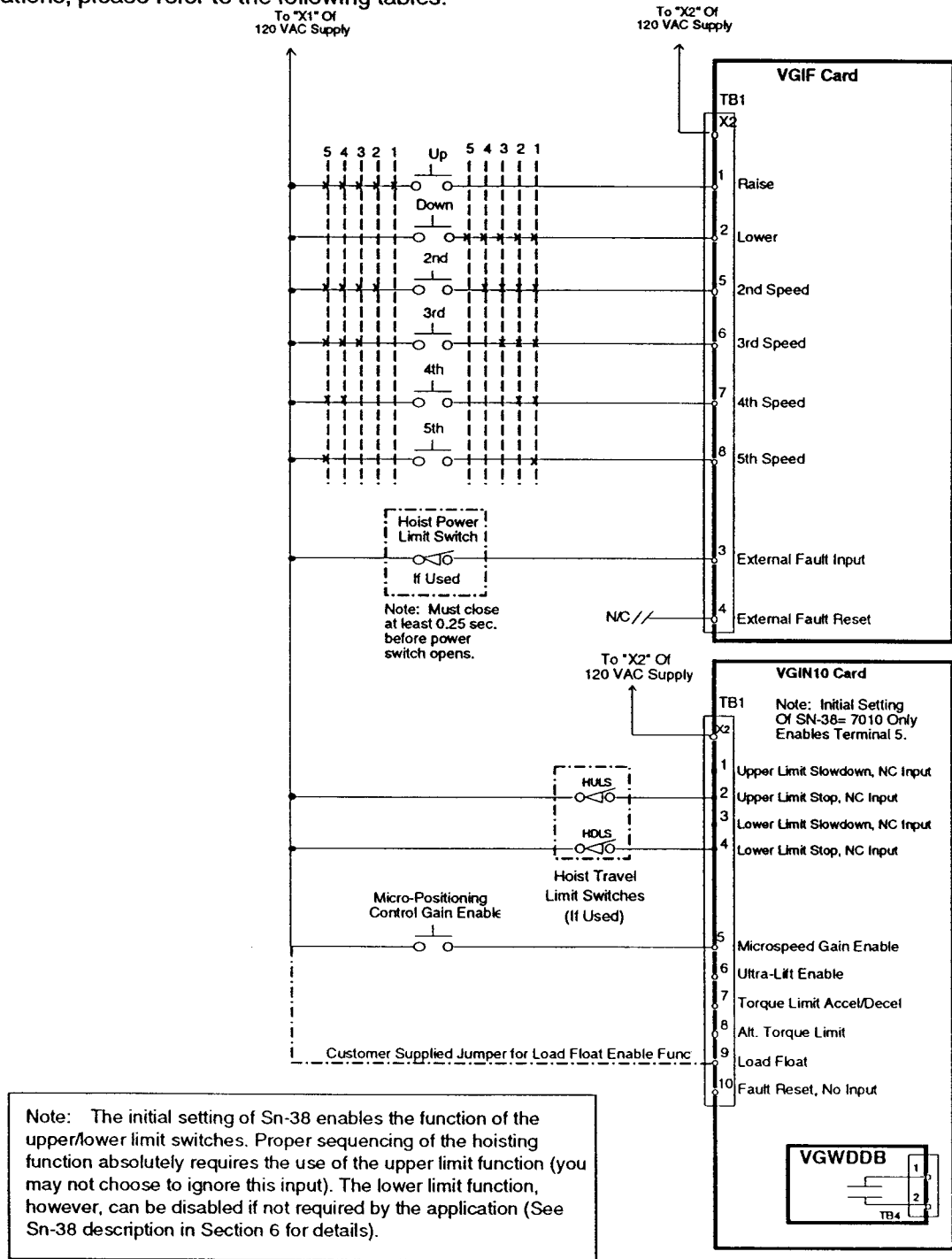

Note: The initial setting of Sn-38 enables the function of the upper/lower limit switches. Proper sequencing of the hoisting function absolutely requires the use of the upper limit function (you may not choose to ignore this input). The lower limit function, however, can be disabled if not required by the application (See Sn-38 description in Section 6 for details).

3.4.2 Control Input Terminal Functions (Continued)

VGIF-120 VAC Interface Card Mounted on the IMPULSE•VG+ Terminal Strip		
VGIF Terminal	Function	Comments
X2	120V Return	120 VAC, nominal input
1	Raise while 120V signal is applied	
2	Lower while 120V signal is applied	
3	External Fault Command (momentary); factory set so 120V signal will produce a fault trip of the IMPULSE•VG+	
4	Fault Reset if 120V signal is momentarily applied	
5	Multi-function input terminal 1; initial set for 2nd step speed	
6	Multi-function input terminal 2; initial set for 3rd step speed	
7	Multi-function input terminal 3; initial set for 4th step speed	
8	Multi-function input terminal 4; initial set for 5th step speed	

VG10-120 VAC Interface Card Mounted on the 2CN Connector of the IMPULSE•VG+		
VG10 Terminal	Function	Comments
X2	120V return	Input is activated with 120 VAC input signal. Parameter Sn-38 determines the function performed by these inputs. Note: Initial setting of Sn-38 only enables terminal 5.
1	Multi-function input; initial set for upper limit slowdown	
2	Multi-function input; initial set for upper limit stop	
3	Multi-function input; initial set for lower limit slowdown	
4	Multi-function input; initial set for lower limit stop	
5	Multi-function input; initial set for Microspeed Gain	
6	Multi-function input; initial set for Ultra-Lift	
7	Multi-function input; initial set for Torque Limit Acc/Dec	
8	Multi-function input; initial set for Alternate Torque Limit	
9	Multi-function input; initial set for Load Float	
10	Multi-function input; initial set for Fault Reset (NO type)	

3.4.2 Control Input Terminal Functions (Continued)

Note: Except as noted below, the application of 120 VAC directly to the IMPULSE•VG+ inverter terminal strip will cause board damage! These terminals are shown for reference only. You should not terminate wiring directly on these terminals.

IMPULSE•VG+ Terminal Strip		
IMPULSE•VG+	Function	Comments
1	Raise while closed	Optically isolated inputs: + 24 VDC, 8 mA
2	Lower while closed	
3	External fault command (momentary); factory set so momentary contact closure will produce fault	
4	Fault reset if momentarily closed (Run commands must first be removed)	
5	Multi-function input terminal 1; initial set for second step speed	
6	Multi-function input terminal 2; initial set for third step speed	
7	Multi-function input terminal 3; initial set for fourth step speed	
8	Multi-function input terminal 4; initial set for fifth step speed	
9/10	Multi-function contact output; initial set for brake release command	Contact rated 1 A @ 250 VAC, 30 VDC
11	Sequence Common (0 V)	-
12	Earth ground for connection of shield sheath	Only connect drive side shield
13	0-10 VDC reference command (if used)	0- 10 VDC (20 k Ω)
14	4-20 mA reference command (if used)	4- 20 mA (250 Ω)
15	+ 15 VDC, 20 mA power supply for speed potentiometer	20 mA, maximum
16	Multi-function analog input; factory set for auxiliary speed command	0- 10 VDC/0- 100% (20 k Ω)
17	Analog common (0 V)	-
18	Fault relay output; 18-20 closes at fault; 19-20 opens at fault	Contact Rated 1 A @ 250 VAC, 30 VDC
19		
20		
21	Multi-function analog output; factory set for speed indication	Output: 0- 11 VDC
22		
23	Output current indication	Output: 5 VDC/100% IMPULSE•VG+ rated current
24		
25	Multi-function PHC output 1; initial set for speed increasing	Optically isolated Output:+ 48 VDC, 50 mA
26	Multi-function PHC output 2; initial set for zero speed	
28	Multi-function PHC output 3; initial set for running 2 (w/excitation)	
29	Multi-function PHC output 4; initial set for minor fault	
27	Multi-function PHC common	
30/31	Thermistor input (optional)	-

3.5 Control Output Terminal Wiring

The control outputs control the action of the brake contactor(s). The sequencing used to control the parking brake is contained within the IMPULSE•VG+. The output of this safety-based sequence is a contact between terminals 9 and 10 which is connected to the brake contactor coil through an auxiliary PC board (the watchdog timer board). Because the IMPULSE•VG+ is a microprocessor-based unit, it relies on the function of a crystal oscillator to operate. If the crystal fails, you can no longer rely on the microprocessor to initiate a brake set command because the MPU is no longer functioning. To counteract this potential failure mode, Electromotive Systems has developed a PC board that monitors the activity of the crystal. If the crystal should fail, for any reason, this board will provide a brake set command.

A redundant contactor arrangement for the brake coil circuit is shown. This is an added safety precaution to prevent the load from falling if two very unlikely events occur simultaneously--a fault trip of the IMPULSE•VG+ and a brake contactor freezing in the "on" position (thereby releasing the parking brake). Please note, as long as the IMPULSE•VG+ is operating (without a fault trip), it will maintain control of the load and provide an output for brake failure indication. The load may be safely lowered, even if the brake contactor or the brake itself has failed.

3.5.1 Control Output Terminal Wiring Precautions

- Always separate 12 VAC wiring from DC control and power wiring. If the two must cross, they should do so at 90° angles.
- You must use R-C type surge suppressors across the coils of the brake contactors to prevent potential nuisance tripping of the IMPULSE•VG+ unit due to excessive magnetic noise when the contactors are de-energized.
- Redundant brake contactors (HBC and HBCB) are used to prevent an unsafe condition resulting from the potential failure of a single device.
- The brake fault output (120 VAC available at VGOUT terminals 3~X2) must be wired to audible/visual alarms. Failure to do this could result in an unsafe condition resulting from removal of power from the IMPULSE•VG+ when the brake has failed. This could result in dropping of the load and pose a safety threat to any nearby personnel.
- All VGOUT outputs are rated 1A, inductive at 120 VAC.

3.5.2 Control Output Wiring - Interconnection Diagram



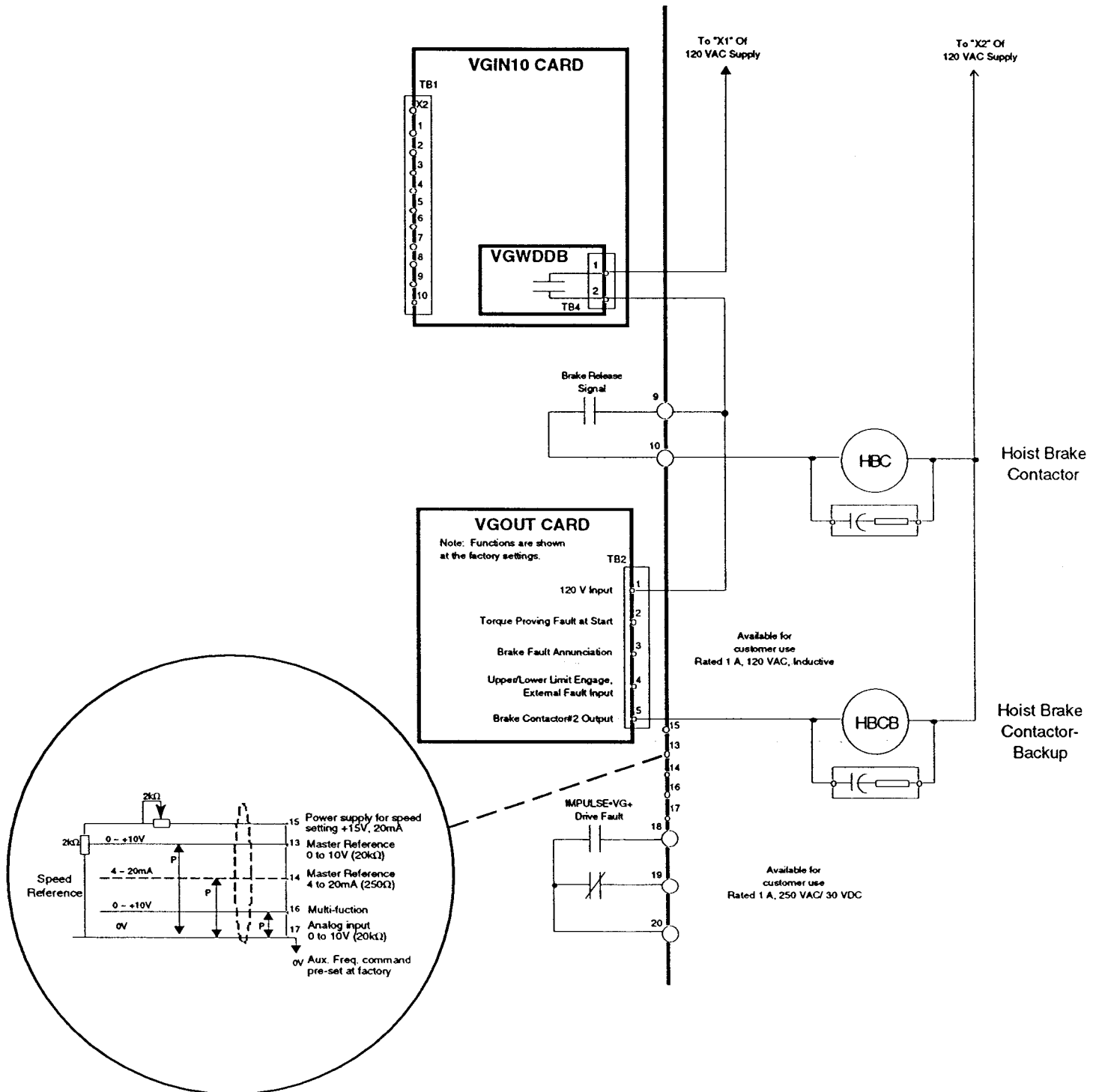





The following wiring diagram shows the initial settings for the multi-function outputs. Please refer to Section 6 for details about programming and capabilities of the IMPULSE•VG+ unit.



Section 4: IMPULSE•VG+ Programming Summary

4.1 Basic Programming

From either the PROGRAM mode or DRIVE* mode:

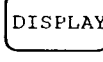
Press 	until the proper prefix is displayed (i.e. An-, Bn-, Sn-, Un-, Dn-, On-, or Cn-).
Press  or 	to get the proper constant (i.e. An-07, Sn-04, etc.).
Press 	to display the current value of the constant.
Press 	to move the cursor until the desired digit is blinking for programmable constants (Un- constants are never programmable, the rest are enabled by Sn-03).
Press  or 	to change the digit. (Change other digits accordingly).
Press 	to store the value for that constant.
Press 	to exit the constant. (Repeat the same process to program other constants).

* In the DRIVE mode, there will be displays in addition to prefixes. These are fault codes and other non-programming related concerns. Simply press DISPLAY to scroll through them.

4.2 Keypad Lockout

Function	Sn-03
Total programming lockout	0001
Total programming enabled	1001

4.3 Speed Control Method

<i>For Multi-Step Speed Control</i>	
Function	Program
Multi-step speed 2	Sn-15 = 00
Multi-step speed 3	Sn-16 = 01
Multi-step speed 4	Sn-17 = 02
Multi-step speed 5	Sn-18 = 03

<i>For Two-Step Infinitely Variable Speed Control (Contact input)</i>	
Function	Program
Accel Command	Sn-15 = 05 (Sn-16 - Sn-18 cannot be 05)

<i>For Three-Step Infinitely Variable Speed Control (Contact input)</i>	
Function	Program
Speed hold 2	Sn-15 = 04
Accel command	Sn-16 = 05 (Sn-17 and Sn-18 cannot be 05)

<i>For Infinitely Variable Speed Control (Joystick input)</i>	
Function	Program
Speed reference by analog	Sn-04 = 0000
Lower Limit = 0.00-20.00%	Bn-15

4.4 Stopping Method

Function	Sn-04
Immediate stop at stop command and set brake	00XX
decel to stop by Bn-02	01XX
decel to stop by Bn-04	10XX
decel to stop by Bn-12	11XX

4.5 Selecting Speeds

Function	Constant
Speed 1/lower limit	An-01
Speed 2	An-02
Speed 3	An-03
Speed 4	An-04
Speed 5	An-05
Upper limit	Cn-05

4.6 Acceleration/Deceleration

Function	Constant
Acceleration time	Bn-01
Deceleration time	Bn-02
Alternate acceleration time	Bn-03
Alternate deceleration time	Bn-04

4.7 IMPULSE•VG+ Special Features

4.7.1 Micro-Positioning Control

Function	Constant
To enable Micro-Positioning Control	Sn-15, Sn-16, Sn-17, or Sn-18 = 0E
Micro-Positioning Control gain	Cn-11
Pre-Program Terminal #TC5 for Micro-Positioning Control	Sn-38 = 71XX

4.7.2 Automatic Load Float

Function	Constant
To enable Load Float	Sn-15, Sn-16, Sn-17, or Sn-18 = 0F
Load Float time	Cn-21
Pre-Program Terminal #TC9 for Load Float	Sn-38 = 71XX

4.7.3 Quick Stop

Function	Constant
To enable Quick Stop	Sn-05(1) = XXX1
Alternate deceleration time	Bn-04

4.7.4 Reverse Plug Simulation

Function	Constant
To enable Reverse Plug Simulation	Sn-06(1) = XXX1
Alternate acceleration time	Bn-03
Alternate deceleration time	Bn-04

4.7.5 Slack Cable Detection

Function	Constant
Slack Cable Detection Torque	Cn-34
Slack Cable Detection Primary Delay	Bn-21
To enable Slack Cable Detection	Sn-20, Sn-21, Sn-22, Sn-23, or Sn-24 = 36

4.7.6 Ultra-Lift

Function	Constant
Ultra-Lift maximum speed	Dn-02
To enable speed	Cn-41 *
Delay time	Cn-42
Maximum reverse torque	Cn-43
% speed limit in reverse	Cn-44

* Cn-41 must be less than or equal to Dn-01.

4.7.7 Alternate Torque Limit

Function	Constant
Alternate Torque Limit gain	Cn-29
To enable Alternate Torque Limit	Sn-15, Sn-16, Sn-17, or Sn-18 = 13
Pre-Program Terminal #TC8 for Alternate Torque Limit	Sn-38 = 7X8X

4.7.8 Nfb is Positive/Nfb is Negative

Function	Constant
PHC/relay is output when Nfb is negative	Sn-20, Sn-21, Sn-22, Sn-23, or Sn-24 = 12
PHC/relay is output when Nfb is positive	Sn-20, Sn-21, Sn-22, Sn-23, or Sn-24 = 13

N = speed

4.7.9 Torque Limit Acceleration/Deceleration Function

Function	Constant
To enable Torque Limit Accel/Decel Sequence	Sn-15, Sn-16, Sn-17 or Sn-18 = 12
Pre-Program Terminal #TC7 for Torque Limit Accel/Decel Sequence	Sn-38 = 7X4X

4.7.10 Upper Limit Functions

<i>Upper Limit 1</i>	
Function	Constant
To enable Upper Limit 1 Sequence	Sn-15, Sn-16, Sn-17, or Sn-18 = 0A
Pre-Program Terminal #TC1 for Upper Limit 1 Sequence	Sn-38 = 7XX1

<i>Upper Limit 2</i>	
Function	Constant
To enable Upper Limit 2 Sequence	Sn-15, Sn-16, Sn-17, or Sn-18 = 0B
Pre-Program Terminal #TC2 for Upper Limit 2 Sequence	Sn-38 = 7XX2

4.7.11 Lower Limit Functions

<i>Lower Limit 1</i>	
Function	Constant
To enable Lower Limit 1 Sequence	Sn-15, Sn-16, Sn-17, or Sn-18 = 0C
Pre-Program Terminal #TC3 for Lower Limit 1 Sequence	Sn-38 = 7XX4

<i>Lower Limit 2</i>	
Function	Constant
To enable Lower Limit 2 Sequence	Sn-15, Sn-16, Sn-17, or Sn-18 = 0D
Pre-Program Terminal #TC4 for Lower Limit 2 Sequence	Sn-38 = 7XX8

Section 5: Digital Keypad

5.1 Operator Layout and Key Functions

The IMPULSE•VG+ is a completely digital controller that can be used to precisely control the motions of a standard three-phase induction motor to facilitate variable speed control. Because it is completely digital, there are no potentiometers or selector switches to adjusted. Instead, the unit is shipped with a standard digital keypad as standard. This powerful device, allows convenient access to the programming parameters, and provides alpha-numeric indication of fault codes to simplify troubleshooting. This digital keypad allows you to:

- Program the various parameters (or constants).
- Read alpha-numeric fault diagnostics.
- Monitor the performance of the unit.

This digital keypad is shown below:

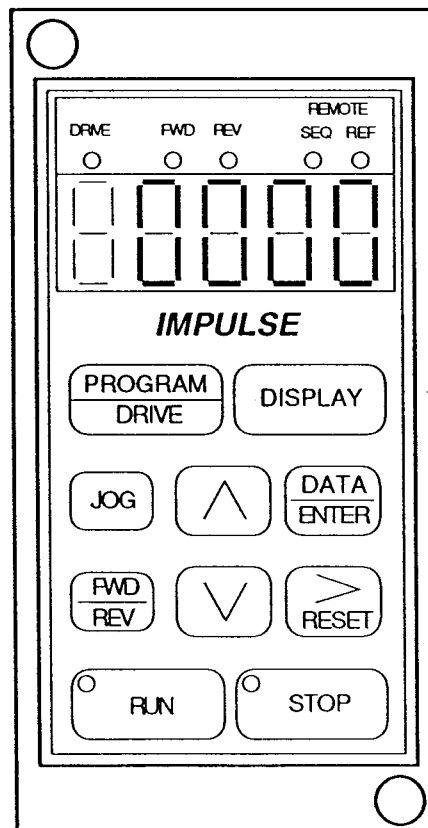

5.2 Programming Mode Key Functions

Some keys on the digital keypad have more than one purpose depending on what operating mode the keypad is in, whether it is to program mode parameters (or constants) or to operate the unit locally. The various keypad functions are listed below whenever the IMPULSE•VG+ is being used to program various parameters (or is in the program mode):

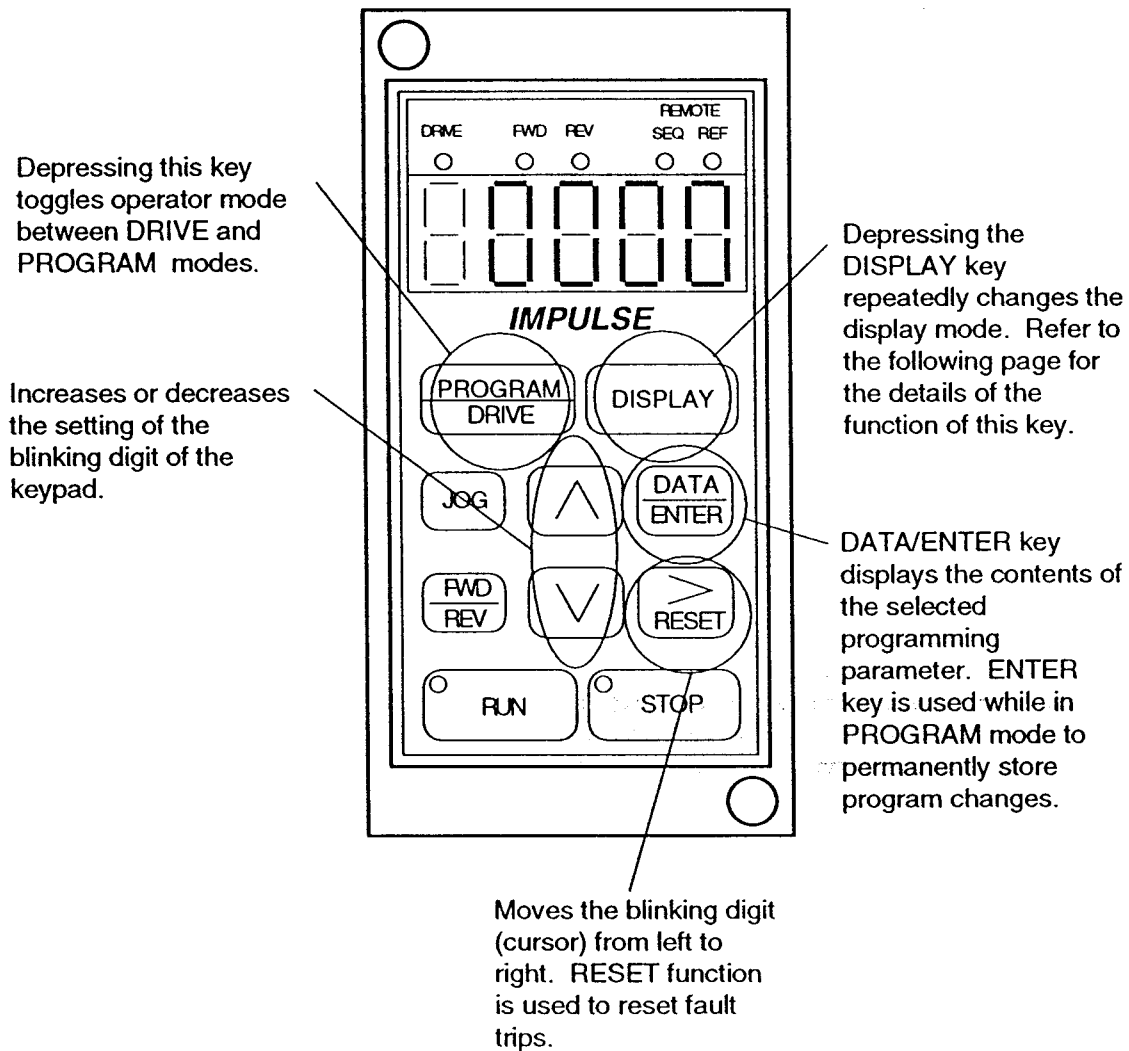

5.2 Programming Mode Key Functions (Continued)

Each time the DISPLAY key is pressed the display mode will change:

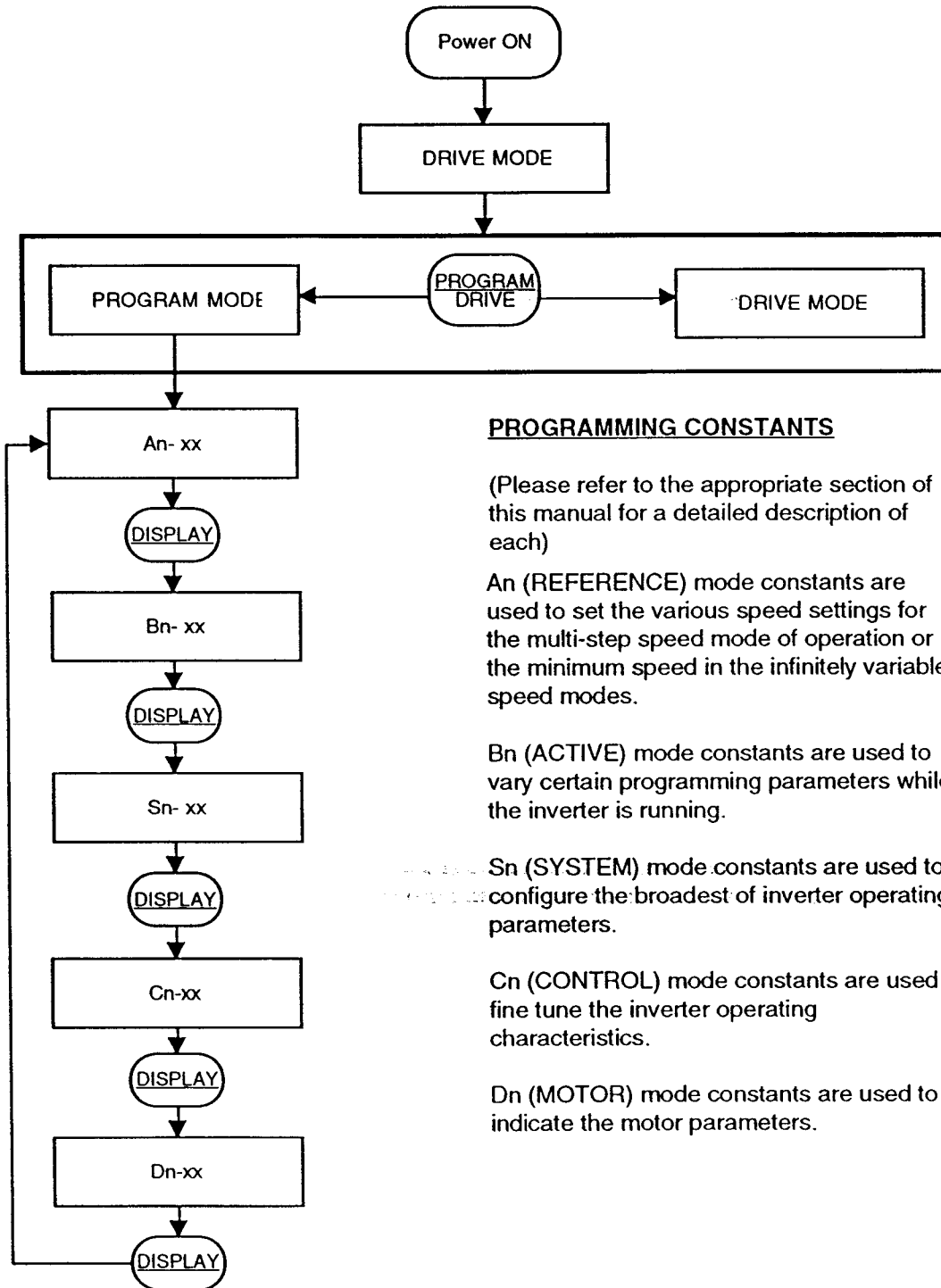

PROGRAMMING CONSTANTS

(Please refer to the appropriate section of this manual for a detailed description of each)

An (REFERENCE) mode constants are used to set the various speed settings for the multi-step speed mode of operation or the minimum speed in the infinitely variable speed modes.

Bn (ACTIVE) mode constants are used to vary certain programming parameters while the inverter is running.













Sn (SYSTEM) mode constants are used to configure the broadest of inverter operating parameters.

Cn (CONTROL) mode constants are used to fine tune the inverter operating characteristics.

Dn (MOTOR) mode constants are used to indicate the motor parameters.

5.3 Changing Constant Data in Program Mode

The following table shows an example of how to change constant data. This demonstrates how to change Cn-11 (Micro-Positioning Control Gain) from data "0.1" to data "0.3", and how to change Cn-21 (Load-Float Time) from data "10" to data "20".

Note: the underlined digit in the keypad display column indicates the cursor position (blinking digit on the display)		Keypad Display
press	 to enter the program mode (you must first be stopped)	An-01
press	 three times to access the Cn family of parameters	Cn-01
press	 until you access parameter Cn-11 (Micro Speed Gain)	Cn-11
press	 once to view the data programmed in this parameter	<u>0</u> .1
press	 to move the blinking digit	0. <u>1</u>
press	 two times to change data from "1" to "3"	0. <u>3</u>
press	 to Enter the new data into Cn-11. Display will show "End" for approx. 1 sec., then will show data again	End ↓ <u>0</u> .3
press	 once to again access the Cn parameter display	Cn-11
press	 until you access parameter Cn-21 (Load Float time)	Cn-12
press	 once to view the data programmed in this parameter	<u>1</u> 0
press	 1 time to change the cursor from "1" to "2"	2 <u>0</u>
press	 to enter the new data in Cn-21. Display will show "End" for approx. 1 sec., then will show the data again.	End ↓ 2 <u>0</u>
press	 to return to the drive (operating) mode	previous display mode

5.4 Local Operator Control Mode Key Functions

(Note: In most cases, local operation is ONLY used for troubleshooting purposes)

The various keypad functions listed below are operational whenever the IMPULSE•VG+ is in the DRIVE mode (or ready to run the motor, either locally, or remotely via external input commands).

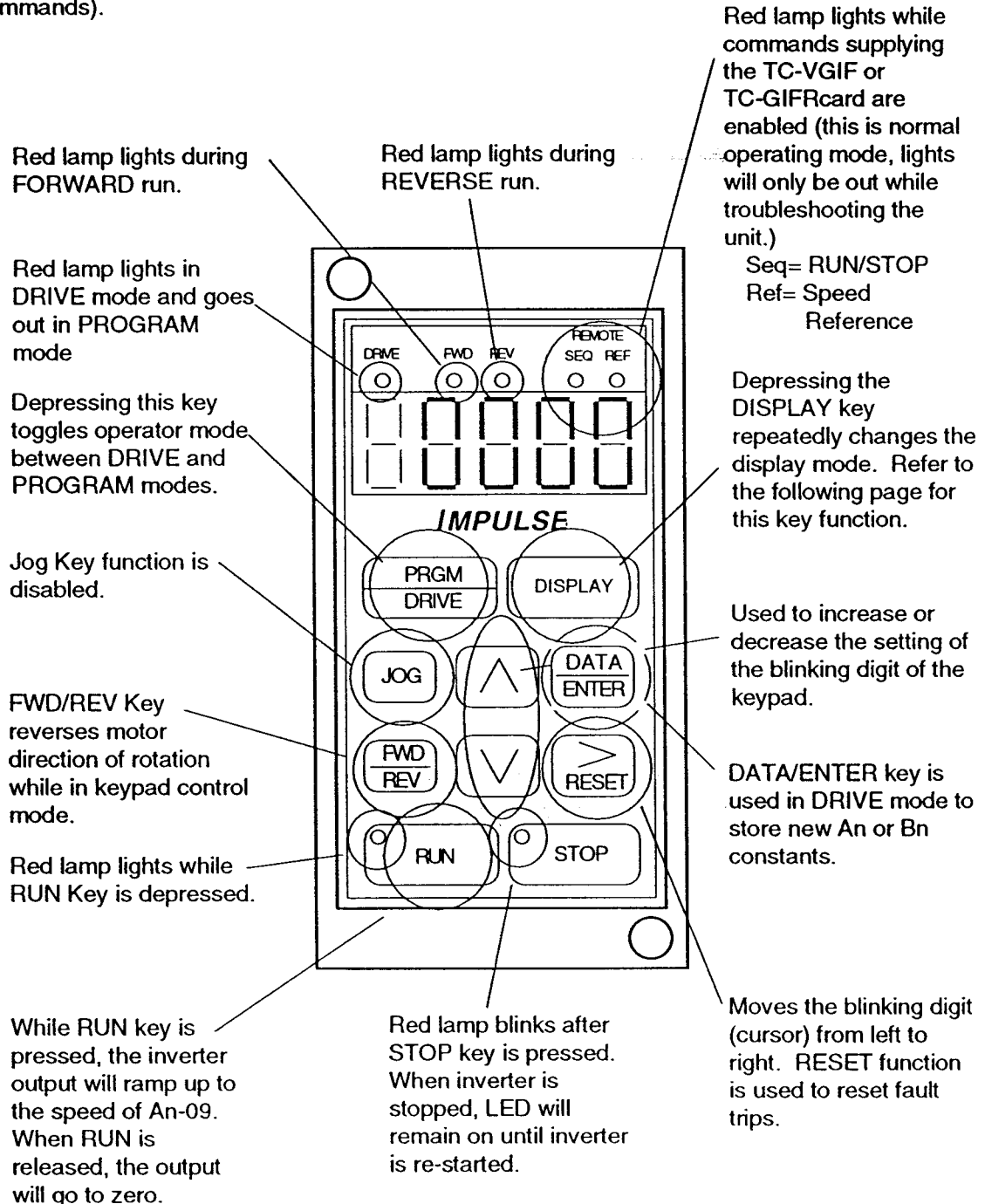

5.4 Local Operator Control Mode Key Functions (Continued)

Each time the DISPLAY key is pressed the display mode will CHANGE:

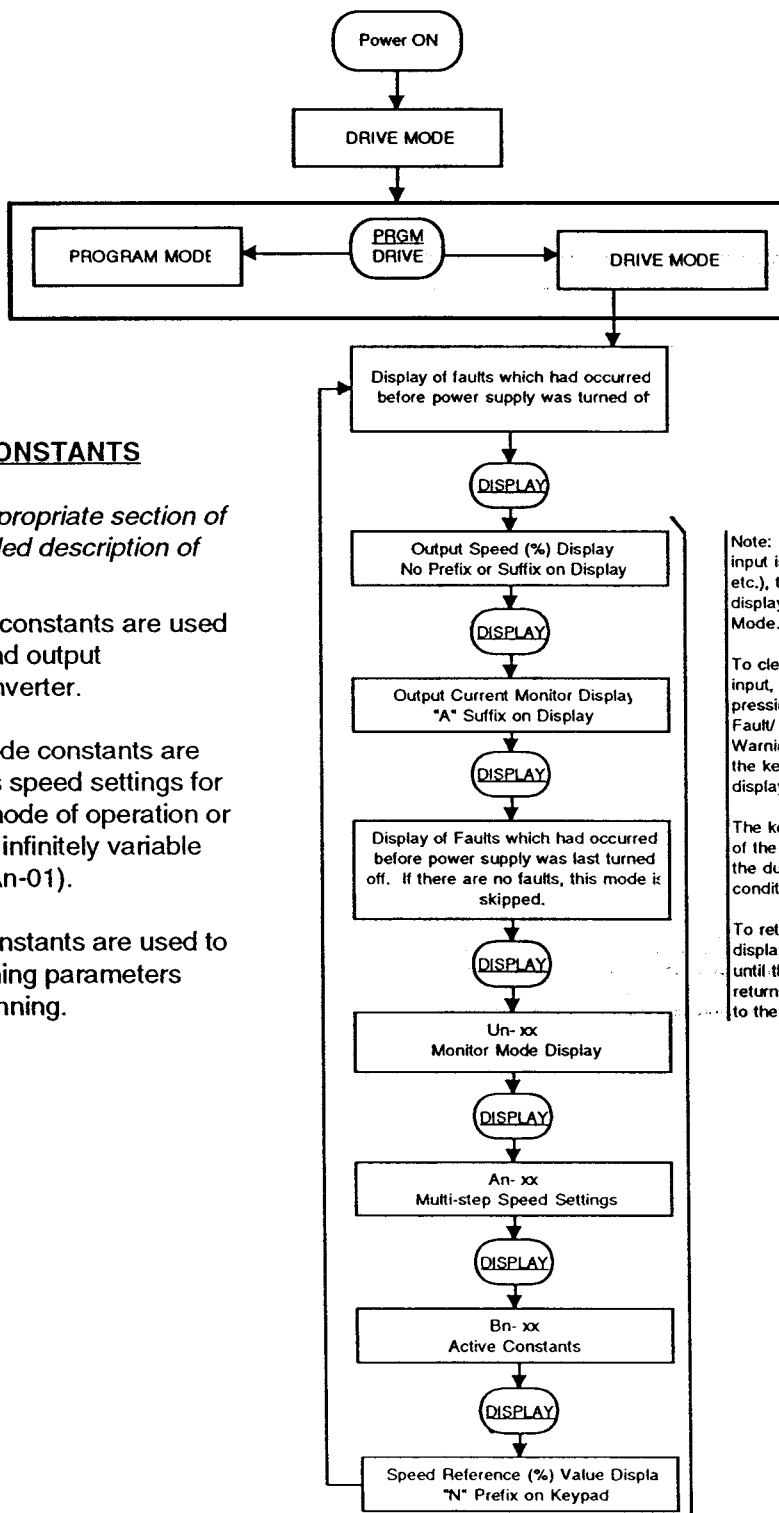

PROGRAMMABLE CONSTANTS

(Please refer to the appropriate section of this manual for a detailed description of each)

Un (MONITOR) mode constants are used to observe the input and output characteristics of the inverter.

An (REFERENCE) mode constants are used to set the various speed settings for the multi-step speed mode of operation or minimum speed in the infinitely variable speed control mode (An-01).

Bn (ACTIVE) mode constants are used to vary certain programming parameters while the inverter is running.

Note: If a Fault occurs or a Warning input is received (Ex. UL2, LL2, etc.), the Fault/ Warning condition is displayed regardless of Display Mode.

To clear the display of Fault/ Warning input, press "DSPL" key. Note that pressing "DSPL" does not reset the Fault/ or internally release the Warning input. "DSPL" only release the keypad to return to the previous display mode.

The keypad will continue to flash all of the uppermost LEDs in unison for the duration of the Fault/ Warning condition.

To return to the Fault/ Warning display, continue to press "DSPL" until the Keypad normal sequence returns to Fault display (subsequent to the Current monitor ("A" prefix).

Section 6: To Begin Programming

6.1 What is a *Constant*?

- In this manual, the term constant simply refers to one of five operating parameters which can be adjusted and/or monitored. These constants are organized according to function and grouped into several constant modes. Each mode carries a two letter code as a designator (either An, Bn, Cn, Dn, Sn, or Un). Therefore, regardless of the existing display, it is very easy to navigate your way through the various programming constants by depressing the DISPLAY key at any time. (Please refer to Section 5.2 for details of the interrelationships between the constant modes.)
- There are five programming constant modes available:
 - Multi-step speed REFERENCE mode (An) Constants.
 - ACTIVE mode (Bn) Constants which can be "tuned" while the inverter is operating.
 - SYSTEM mode (Sn) Constants are available to set the inverter's broadest operating characteristics (i.e. input/output characteristics, V/F pattern).
 - CONTROL mode (Cn) Constants are used to fine tune the inverter operation.
 - MOTOR mode (Dn) Constants are used for programming motor data.
- In addition, there is one group of constants used specifically to monitor the input and output characteristics of the inverter. These are called the MONITOR mode (Un) Constants. These functions essentially eliminate the need for external test equipment or meters at the time of start-up. If a fault trip occurs, these constants can also be very useful in the troubleshooting process. Please see Section 6.7 for more information.

6.1.1 Access to Various Constants

- There are several levels of accessibility to the programming constant modes. These options are controlled by Sn-03 and is located within the SYSTEM mode grouping.
- See Section 6.4 for a detailed description of these various access levels.

6.2 Multi-Step Speed Reference Constants (An Constants)

Following is a table illustrating the relationships between the An constant mode and the available preset speeds.

Number	Name	Increment	Setting Range	Initial Value
An-01	Speed 1/Lower Limit	0.01%	0.00 ~ 100.00%	10.00%
An-02	Multi-Step Speed 2	0.01%	0.00 ~ 100.00%	25.00%
An-03	Multi-Step Speed 3	0.01%	0.00 ~ 100.00%	50.00%
An-04	Multi-Step Speed 4	0.01%	0.00 ~ 100.00%	75.00%
An-05	Multi-Step Speed 5	0.01%	0.00 ~ 100.00%	100.00%
An-06	Multi-Step Speed 6	0.01%	0.00 ~ 100.00%	0.00%
An-07	Multi-Step Speed 7	0.01%	0.00 ~ 100.00%	0.00%
An-08	Multi-Step Speed 8	0.01%	0.00 ~ 100.00%	0.00%
An-09	Multi-Step Speed 9/Jog Speed (Keypad and Terminal)	0.01%	0.00 ~ 100.00%	10.00%

Speed Reference	Forward/Reverse	Multi-Step Speed 2	Multi-Step Speed 3	Multi-Step Speed 4	Multi-Step Speed 5
STOP	O	-	-	-	-
An-01	X	O	O	O	O
An-02	X	X	O	O	O
An-03	X	X	X	O	O
An-04	X	X	X	X	O
An-05	X	X	X	X	X
An-06	X	O	X	O	O
An-07	X	O	X	X	O
An-08	X	O	O	X	O
An-09	X	X	O	X	O
O = Open or Not Selected X = Closed - = Not Applicable					

6.3 Active Mode (Bn) Constants

Number	Name	Increment	Setting Range	Initial Value
Bn-01	Acceleration time 1	0.1 Sec	0.5 ~ 3000.0	5.0
Bn-02	Deceleration time 1	0.1 Sec	0.5 ~ 3000.0	5.0
Bn-03	Alternate acceleration time	0.1 Sec	0.5 ~ 3000.0	1.0
Bn-04	Alternate deceleration time	0.1 Sec	0.5 ~ 3000.0	1.0
Bn-05	ASR proportional gain	1	0 ~ 300	30
Bn-06	ASR integral time (mSec)	1	0 ~ 30000	800
Bn-07	Raising torque limit	0.01%	0.00 ~ 300.00%	120.00
Bn-08	Lowering torque limit	0.01%	0.00 ~ 300.00%	120.00
Bn-09	Regenerating torque limit	0.01%	0.00 ~ 300.00%	150.00
Bn-10	Rated speed adjustment	.1%	.5 - 1.3	1.0
Bn-11	Brake proving speed ref. at start/stop	0.01%	-10.00 ~ +10.00	+2.00
Bn-12	Emergency stop time	0.01 Sec	0.5 ~ 3000.0s	1.0
Bn-13	Monitor function/power Up	1	1 ~ 3	2
Bn-14	PG division ratio (PG-B)	1	1 ~ 132	2
Bn-15	Zero speed adjustment	0.01%	-50.00 ~ +50.00	0.00
Bn-16	Voltage adjustment	0.001%	0.800 ~ 1.200	1.000
Bn-17*	Analog output 1 selection (Terminals 21 ~ 22 Function)	1	1 ~ 41**	23
Bn-18	Analog output 1 gain (Terminals 21 ~ 22 Function)	0.001	0.000 ~ 10.000	1.000
Bn-19	S-Curve time 1	0.1s	0.0 ~ 10.0s	0.0
Bn-20	V/F test mode multiplier	0.1	1.0 - 1.5	1.1
Bn-21	Slack Cable Detection Primary Delay Time	0.01 Sec	0.00 ~ 2.55	0.50
Bn-22 (AO-12)	Option analog output 1 Selection (Terminals TD1 ~ TD3)	1	1 ~ 41**	22
Bn-23 (AO-12)	Option Analog Output 1 Gain (Terminals TD1 ~ TD3)	0.001	0.000 ~ 10.000	1.000
Bn-24 (AO-12)	Option Analog Output 2 Selection (Terminals TD2 ~ TD3)	1	1 ~ 41**	23
Bn-25 (AO-12)	Option Analog Output 2 Gain (Terminals TD2 ~ TD3)	0.001	0.000 ~ 10.000	1.000
<p>*Note: Function of built-in analog channel 2 (Terminals 23 ~ 24) is fixed. Output is proportional to I-Out (5V/ 100%)</p> <p>**Refer to function of Un constant number (i.e. speed out = 23 for Un 23)</p>				

6.4 System Mode (Sn) Constants

Number	Name	Digit Number	Data/ Increment	Remarks/Function	Initial Value	Data Range
Sn-01	KVA Selection	-	01	Inverter Capacity and Voltage is Selected	*	01 ~ 52

Hp	Sn-01 230V Data	230V IMPULSE•VG+ Model Number	Sn-01 460V Data	460V IMPULSE•VG+ Model Number
1	01	230AFD1-VG+		-
3	03	230AFD3-VG+	23	460AFD3-VG+
5	04	230AFD5-VG+	24	460AFD5-VG+
7.5	05	230AFD7.5-VG+	-	-
10	06	230AFD10-VG+	26	460AFD10-VG+
15	07	230AFD15-VG+	27	460AFD15-VG+
20	08	230AFD20-VG+	28	460AFD20-VG+
30	0A	230AFD30-VG+	2A	460AFD30-VG+
40	0B	230AFD40-VG+	2B	460AFD40-VG+
50	0C	230AFD50-VG+	-	-
60	-	-	2D	460AFD60-VG+
75	0E	230AFD75-VG+	2E	460AFD75-VG+
100	0F	230AFD100-VG+	2F	460AFD100-VG+
150	-	-	31	460AFD150-VG+
200	-	-	33	460AFD200-VG+
250	-	-	34	460AFD250-VG+
300	-	-	35	460AFD300-VG+
400	-	-	36	460AFD400-VG+

6.4 System Mode (Sn) Constants (Continued)

Number	Name	Digit Number	Data/Increment	Remarks/Function	Initial Value	Data Range
Sn-02	Motor Selection	--	001	Motor's Dn Constant is selected	FFF	000 - FFF
Sn-03	Operation Status	--	0001	Enables reading and changing of Constants as below:	1000	0000 - 1010

Sn-03	Drive Mode			Program Mode		
	Setting and Reading is Enabled	Only Reading is Enabled	Setting and Reading is Disabled	Setting and Reading is Enabled	Only Reading is Enabled	Setting and Reading is Disabled
0000*	An, Bn	Cn, Dn, Sn, Un	On	An, Bn, Cn, Dn, Sn		On
0101*	An	Bn, Cn, Dn, Sn, Un	On	An, Sn-03	Bn, Cn, Dn, Sn	On
1010*	An, Bn	Cn, Dn, Sn, On, Un		An, Bn, Cn, Dn, Sn, On		
1001^	An, Bn, Cn, Dn, On	Sn, Un		An, Bn, Cn, Dn, Sn, On		
† 0001^		An, Bn, Un	Cn, Dn, Sn, On	Sn-03	An, Bn, Cn, Dn, Sn	On
† 1000^		An, Bn, Un	Cn, Dn, Sn, On	Sn-03	An, Bn, Cn, Dn, Sn	On
0011^	An	Bn, Un	Cn, Dn, Sn, On	An, Sn-03	Bn, Cn, Dn, Sn	On
*Note: Data returns to "0101" at Power Up.						
^Note: Held as is at Power Up						
Remark: Sn-xx, Cn-xx, Dn-xx, On-xx can be directly accessed by depressing the DISPLAY simultaneously with >.						

† Total Lockout Mode

6.4 System Mode (Sn) Constants (Continued)

Number	Name	Digit Number	Data/Increment	Remarks/Function	Initial Value*	Data Range
Sn-04	Operation Mode Selection 1	1	0	Speed Ref. by analog reference or option	0001	0000-1111
			1 †	Speed Ref. by An-01 - An-09 (Internal Ref.)		
		2	0 †	Start/Stop by external terminals		
			1	Start/Stop by the digital operator		
		4, 3	00 †	Stop Button: Immediate Stop and set brake		
			01	Stop Button: Decel to Stop by Bn-02		
			10	Stop Button: Decel to Stop by Bn-04		
Sn-05	Operation Mode Selection 2	1	0	Quick Stop Disabled (Decel by Bn-02)	0001	0000-1111
			1 †	Quick Stop Enabled (Decel by Bn-04)		
		2	0 †	Run reverse is enabled		
			1	Run reverse is disabled		
		3	0 †	Run forward is enabled		
			1	Run forward is disabled		
		4	0 †	Operation Input Line Loss at L1 or L2--Minor Fault (Bn-12)		
1	Operation Input Line Loss at L1 or L2--Major Fault (Bn-12)					
Sn-06	Operation Mode Selection 3	1	0 †	Reverse Plug Simulation is disabled	0000	0000-1111
			1	Reverse Plug Simulation is enabled		
		2	0 †	Not Used		
			1			
		4, 3	00 †	SRMIN Function is Disabled		
			01	Zero Speed Control Enabled (Ref. ≤Cn-06)		
			10	Start/Stop by Speed Ref. (Cn-06)		
11	Not Used					
Sn-07	Operation Mode Selection 4	1	0 †	Coasting Pull-In Function is Provided	0000	0000-1111
			1	Coasting Pull-In Function is Not Provided		
		2	0 †	P-I Control Mode at Zero Speed		
			1	P Control Mode at Zero Speed		
		4, 3	00 †	Not Used		
			01			
			10			
			11			

*Digits read right to left. 0000
 4th digit 1st digit

† Initial value

6.4 System Mode (Sn) Constants (Continued)

Number	Name	Digit Number	Data/Increment	Remarks/ Function	Initial Value	Data Range
Sn-08	Operation Mode Selection 5	1	0 †	Option Card Reference is Enabled	0000	0000-1111
			1	Digital Operator/Ext. Terminal Ref. is Enabled		
		2	0 †	Start/Stop by Option Card		
			1	Start/Stop by the Digital Operator/ Ext. Terminals		
		3	0 †	Not Used		
			1			
		4	0 †	Minor Fault Automatic Reset		
			1	Minor Fault Reset by External Terminals		
Sn-09	Operation Mode Selection 6	1	0 †	Input Voltage is High (220V/440V/460V)	0000	0000-1111
			1	Input Voltage is Low (200V/400V)		
		2	0 †	Not Used		
			1			
		3	0 †	Not Used		
			1			
		4	0 †	Carrier Frequency is 2.08 kHz		
			1	Carrier Frequency is 12 kHz		
Sn-10	Operation Mode Selection 7	2, 1	00	Decel to Stop at Excessive Dev Fault	0101	0000-1111
			01 †	Immediate Stop at Excessive Dev Fault		
			10	Emergency Stop (Bn-12) at Excessive Dev Fault		
			11	Do Not Use		
		4, 3	00	Decel to Stop at Overspeed Fault		
			01 †	Immediate Stop at Overspeed Fault		
			10	Emergency Stop (Bn-12) at Overspeed Fault		
			11	Do Not Use		
Sn-11	Protection Characteristics Selection 1	1	0 †	Built-in Braking Resistor Not Provided	0000	0000-1111
			1	Built-in Braking Resistor Provided		
		2	0 †	No Fault Output during Retry		
			1	Fault Output during Retry		
		4, 3	00 †	Immediate Stop at Undervoltage Detection		
			01	Automatic Retry at Undervoltage Detection		
			10	Undervoltage Level is 80% level		
			11	Undervoltage Level is set by Cn-17		

† Initial value

6.4 System Mode (Sn) Constants (Continued)

Number	Name	Digit Number	Data/Increment	Remarks/Function	Initial Value	Data Range
Sn-12	Protection Characteristics Selection 3 (External Fault Input on Terminal Number 3)	1	0 †	External Fault at Closed (N/O Contact)	0100	0000-1111
			1	External Fault at Open (N/C Contact)		
		2	0 †	External Fault is Always Detected		
			1	External Fault is NOT detected at Immediate Stop		
		4, 3	00	Decel to Stop at External Fault		
			01 †	Immediate Stop at External Fault		
			10	Emergency Stop (Bn-12) at External Fault		
11	Continuous Operation at External Fault					
Sn-13	Protection Characteristics Selection 4	2, 1	00 †	Decel to Stop at OL2 Fault	0000	0000-1111
			01	Immediate Stop at OL2 Fault		
			10	Emergency Stop (Bn-12) at OL2 Fault		
			11	Continuous Operation at OL2 Fault		
		4, 3	00 †	Decel to Stop at FAN Fault		
			01	Immediate Stop at FAN Fault		
			10	Emergency Stop (Bn-12) at FAN Fault		
			11	Continuous Operation at FAN Fault		
Sn-14	Protection Characteristics Selection 5	2, 1	00 †	Decel to Stop at OL1 Fault	0000	0000-1111
			01	Immediate Stop at OL1 Fault		
			10	Emergency Stop (Bn-12) at OL1 Fault		
			11	Continuous Operation at OL1 Fault		
		4, 3	00 †	Decel to Stop at OH1 Fault		
			01	Immediate Stop at OH1 Fault		
			10	Emergency Stop (Bn-12) at OH1 Fault		
			11	Continuous Operation at OH1 Fault		
Sn-15	Multi-Function Input 1 (T5)	-	Hex Code	Sets the Function of Terminal 5 (See Next Page)	00	00 - FF
Sn-16	Multi-Function Input 2 (T6)			Sets the Function of Terminal 6 (See Next Page)	01	
Sn-17	Multi-Function Input 3 (T7)			Sets the Function of Terminal 7 (See Next Page)	02	
Sn-18	Multi-Function Input 4 (T8)			Sets the Function of Terminal 8 (See Next Page)	03	

† Initial value

6.4 System Mode (Sn) Constants (Continued)

Sn-15 – Sn-18: Multi-Function (Soft) Input Terminals 5 - 8 on VGIF Card	
Data	Description
00	Multi-Step Speed 2
01	Multi-Step Speed 3
02	Multi-Step Speed 4
03	Multi-Step Speed 5
04	Speed Hold 2 (2nd Step of 3 Step Infinitely Variable Mode)
05	Accel Command (3rd Step of 3 Step/ 2nd Step of 2 Step Infinitely Variable Modes)
06	Upper Limit 1 (Slow to An-01 by Bn-12) (N/O Contact)
07	Upper Limit 2 (Stop by Bn-12) (N/O Contact)
08	Lower Limit 1 (Slow to An-01 by Bn-12) (N/O Contact)
09	Lower Limit 2 (Stop by Bn-12) (N/O Contact)
0A	Upper Limit 1 (Slow to An-01 by Bn-12) (N/C Contact)
0B	Upper Limit 2 (Stop by Bn-12) (N/C Contact)
0C	Lower Limit 1 (Slow to An-01 by Bn-12) (N/C Contact)
0D	Lower Limit 2 (Stop by Bn-12) (N/C Contact)
0E	Micro-Positioning Control Gain (Cn-11)
0F	Load Float (Cn-21)
10	Micro-Positioning Control Gain + Load Float (Cn-11 and Cn-21)
11	Ultra-Lift Enable (Cn-41 through Cn-44)
12	Torque Limit Acc/ Dec
13	Alternate Torque Limit (Cn-29)
14	Accel/Decel Time Selection (Closed = Bn-03/ Bn-04)
15	Operation Signal Selection (Closed = Operator Control)
16	Option/ Inverter Changeover Selection (Closed = Inverter)
17	External Immediate Stop at Stop Command (N/O Contact)
18	External Immediate Stop at Stop Command (N/C Contact)
19	Inverter Overheating Prediction
1A	Aux. Analog Input Effective
1B	ASR Integral Reset
1C	Fault Reset (N/O Contact)
1D	Fault Reset (N/C Contact)
1E	Alternate Speed Reference Upper Limit
20-2F	External Fault Input (EF1)
30	Initial Excitation
31	Speed Control/Torque Control Changeover (Closed = Torque)
32	Zero Servo
33	S-Curve Time Selection (Closed = Cn-26)
34	ASR Integral Hold
35	Load Input Selection
36	Battery Operation
37	Brake Answer Back
FF	Terminal is not Used (no connection)

6.4 System Mode (Sn) Constants (Continued)

Fault Code Programming (Sn-15 ~ Sn-18 = 20 ~2F)

Terminals 5 ~ 8 can be programmed for inputing an External Fault (EF). The operation of the IMPULSE•VG+ at Fault Input can be programmed by the data of Sn-15 ~ Sn-18 as below:

Ex. Data = 2 X

Convert to 4 digit Binary then to single hexadecimal number (see page 56)

Digit Number	Data/ Increment	Remarks/Function
1	0	External Fault at Closed (N/O Contact)
	1	External Fault at Open (N/C Contact)
2	0	External Fault is Always Detected
	1	External Fault is NOT detected at Base Block
4, 3	00	Decel to Stop at External Fault
	01	Immediate Stop at External Fault
	10	Emergency Stop (Bn-12) at External Fault
	11	Continuous Operation at External Fault

Multi-Function Analog Input (Sn-19)						
Number	Name	Digit Number	Data/ Increment	Remarks/Function	Initial Value	Data Range
Sn-19	Multi-Function Analog Input Terminals 16 -17	--	Hex Code	Sets the Function of Aux. Analog Input Channel	00	00 - 06

Data	Description
00	Aux. Speed Reference
01	Speed Bias (10V/+10%)
02	Speed Bias (10V/-10%)
03	Torque Limit 1 (5V/100%)
04	Torque Limit 2 (3V/100%)
05	Torque Compensation Input 1 (5V/100%)
06	Torque Compensation Input 2 (3V/100%)

6.4 System Mode (Sn) Constants (Continued)

Multi-Function Output Programming (Sn-20 ~ Sn-24) (VGOUT Interface Card)						
Number	Name	Digit Number	Data/ Increment	Remarks/Function	Initial Value	Data Range
Sn-20	Multi-Function Relay Out 1	--	Hex Code	Sets the Function of 9 - 10 (See Below)	3F	00 - FF
Sn-21	Multi-Function VGOUT Term. 2			Sets the Function of 2 (See Below)	47	
Sn-22	Multi-Function VGOUT Term. 3			Sets the Function of 3 (See Below)	60	
Sn-23	Multi-Function VGOUT Term. 4			Sets the Function of 4 (See Below)	BD	
Sn-24	Multi-Function VGOUT Term. 5			Sets the Function of 5 (See Below)	3F	

Data	Description
00	Running (Run X)
01	Zero Speed
02	Speed Coincidence (AGREE)
03	Desired Speed Coincidence (AGREE 2) (Cn-02)
04	Speed Detection 1 (NDET 1)
05	Speed Detection 2 (NDET 2)
06	Operation Ready
07	Undervoltage Detection
08	Immediate Stop at Stop Command (BB1)
09	Speed Reference Mode (closed at operator effective)
0A	Start/Stop Reference Mode (closed at operator effective)
0D	Braking Transistor Fault (rr)
0E	Fault (FLT X) Excluding CPF00, CPF01
0F	DO Function (flag force by serial communication)
10	Minor Fault Output (warning alarm for brake failure)
11	Reset Signal Input
12	Forward Running
13	Reverse Running
30	Torque Limiting
31	Speed Reference Input Limiting
32	Torque Reference Limiting at Low Frequency by On-07
33	Load Float Completion
34	Motor Temperature Detection (Closed = Motor Temp \geq Cn-28)
35	Desired Torque Detection 1 (Closed = Int. Torque Ref. \geq Cn-33)
36	Slack Cable Detection 1 (Closed = Int. Torque Ref. \leq Cn-34)
37	Running 2 (considers excitation command)
3D	Speed Increasing
3F	Brake Command for Hoisting Sequence
40-FF	Fault Annunciation (see next page for example)

6.4 System Mode (Sn) Constants (Continued)

Sn-21~24 Fault Annunciation Programming Method and Example

Example: A certain application requires an alarm at all sequence (SE and BE type) faults. You can use the table below to determine that the correct data would be "67".

Conversion Chart			Digit 2		Digit 1			
Hexadecimal	Decimal	Binary	6		7			
0	0	0000	0	1	0	1	1	1
1	1	0001						
2	2	0010						
3	3	0011						
4	4	0100						
5	5	0101						
6	6	0110						
7	7	0111						
8	8	1000						
9	9	1001						
A	10	1010						
B	11	1011						
C	12	1100						
D	13	1101						
E	14	1110						
F	15	1111						

Menu Select	Fault Annunciation					
Binary Code	0 = Fault is Not Output to PHC, 1 = Fault IS Output to PHC					
1 1	OS	DEV	LF	-	OL2	OL1
1 0	UL2	UL1	LL2	LL1	LF	EF1
0 1	BE6	-	-	BE3	BE2	BE1
	SE6			SE3	SE2	SE1

Sn-25 AI-14B (±10V Input Option Card) Function Select						
Number	Name	Digit Number	Data/Increment	Remarks/ Function	Initial Value	Data Range
Sn-25	AI-14B Function Selection	--	Binary Code	Sets the Function of each of Three Analog Channels	0000	0000 - 0011

Sn-25 Set Value	Control Mode	Channel 1 (Cn-30)	Channel 2 (Cn-31)	Channel 3 (Cn-32)
0000	Speed Control 1	Speed Reference	--	--
0001	Speed Control 2	Speed Reference	Aux. Speed Reference	Torque Compensation
0010	Speed Control 3	Speed Reference	FWD Side Torque Limit	REV Side Torque Limit
0011	Speed Control 4	Speed Reference	Both Sides Torque Limit	Torque Compensation

6.4 SYSTEM Mode (Sn) Constants (Continued)

Sn-26 DI-16 (16 bit Digital Input Option Card) Function Select						
Number	Name	Digit Number	Data/ Increment	Remarks/ Function	Initial Value	Data Range
Sn-26	DI-16 Function Selection	--	Binary Code	Sets the Function of DI-16 (Digital Input Reference)	0001	0001 - 0111

Sn-26 Set Value	Input Data Format (4 Digits)
0001	BCD 0.01% Accuracy (-109.2 to +109.2%)
0010	BCD 0.1% Accuracy (-109.2 to +109.2%)
0111	BINARY (-32768 to +32768, 30000/100%)

6.4 SYSTEM Mode (Sn) Constants (Continued)

Sn-27 DO-08 (8 Bit Digital Output Option Card) Function Sheet						
Number	Name	Digit Number	Data/Increment	Comments/Function	Initial Value	Data Range
Sn-27	DO-08 Function Selection	-	Binary Code	Sets the Function of DO-08 (Digital Output Reference)	0000	0001 - 0001

Sn-27 Set Value	DO-08 Bit 0 - 7	Output Function (Combination 1)
0000	PHC 1	Overcurrent (OC Fault)
	PHC 2	Overvoltage (OV) Fault
	PHC 3	Inverter Overload/Overheat (OL2, OH)
	PHC 4	Fuse Blown (FU)
	PHC 5	Overspeed (OS)
	PHC 6	Motor Overload, Overheat (OL1, OH1)
	Contact 1	Zero Speed (ZSP)
	Contact 2	Speed Agree (AGREE)
	DO-08 Bit 0 - 3	Output Function (Combination 2) Output is Binary Coded
0001	0000	No Fault
	0001	Overcurrent (OC Fault)
	0010	Overvoltage (OV) Fault
	0011	Inverter Overload (OL2)
	0100	Inverter Overheat (OH2)
	0101	Overspeed (OS)
	0110	Fuse Blown (FU)
	0111	Open Phase (LF)
	1000	External Fault (EFG)
	1001	Inverter Hardware Fault (CPFG)
	1010	Motor Overload (OL1)
	1011	Motor Overheat (OH1)
	1100	Power Loss (UV)
	1101	Excess Speed Deviation (DEV)
	1110	PG Disconnect (PG0)
	1111	Cooling Fan Fault (FAN)
	DO-08 Bit 4 - 7	
	PHC 5	Zero Speed (ZSP)
	PHC 6	Speed Agree (AGREE)
	Contact 1	Run Output (RUN)
	Contact 2	Minor Fault (ALM)

Number	Name	Digit Number	Data/Increment	Remarks/Function	Initial Value	Data Range
Sn-28 - Sn-35	Not used	-	-	Reserved for future use	-	-
Sn-36	Upper limit Input Action Selection	1	0	Decel to Stop by Bn-12	1	0001-1000
			1 †	BB to Stop - First Priority		
		2 - 4	Data must be 0	Reserved for future use	0	
Sn-37	Not Used	-	-	Reserved for future use	-	-

6.4 SYSTEM Mode (Sn) Constants (Continued)

Sn-38 VGIN-10 Function Select						
Number	Name	Digit Number	Data/Increment	Remarks/Function	Initial Value	Data Range
Sn-38	VGIN 10 Function Select	--	Binary/Hex Code	Provides for 10 Additional Soft Input Terminals--Sn-38 Sets the Function and Status of each Addition Terminal	711A	0000-E3FF

Sn-38 Programming Method

Sn-38 function provides for an additional 10 multi-function terminal inputs using the option card VGIN 10 terminals designated TC1 ~ TC10. Sn-38 is programmed in hex code. The hex value is converted from binary code for digits 1, 2, and 3. (See conversion chart on page 56.) Digit 4 (column 1 in black below) selects the available terminal functions. The code under each of the TC1~TC10 columns is taken from the Multi-Function Input menu found on page 53 and again on the next page. The programming scheme is depicted as below.

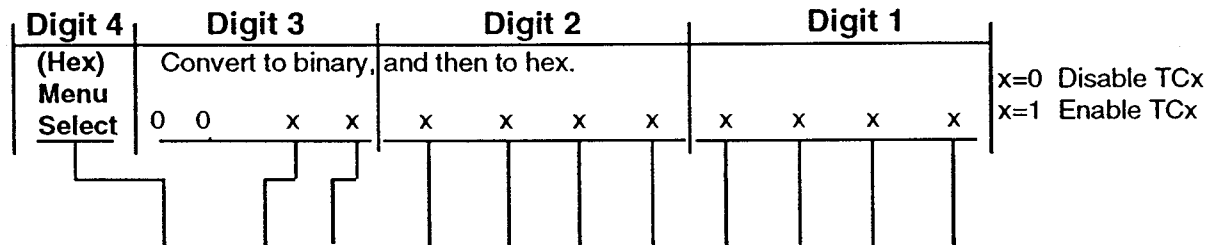

VGIN 10 Terminal Number/ Function Code										
Code (Hex)	TC10	TC9	TC8	TC7	TC6	TC5	TC4	TC3	TC2	TC1
0	Disable Multi-Function Terminal Input by VGIN 10									
1	1A	1C	13	12	11	10	0D	0C	0B	0A
2	1A	1C	13	12	11	10	09	08	07	06
3	1E	1C	13	12	11	10	0D	0C	0B	0A
4	1E	1C	13	12	11	10	09	08	07	06
5	1E	1A	13	12	11	10	0D	0C	0B	0A
6	1E	1A	13	12	11	10	09	08	07	06
7	1C *	0F *	13 *	12 *	11 *	0E *	0D *	0C *	0B *	0A *
8	1C	0F	13	12	11	0E	09	08	07	06
9	1E	0F	13	12	11	0E	0D	0C	0B	0A
A	1E	0F	13	12	11	0E	09	08	07	06
B	1E	0F	13	17	11	0E	0D	0C	0B	0A
C	1E	0F	13	17	11	0E	09	08	07	06
D	1A	17	13	12	11	10	0D	0C	0B	0A
E	1A	17	13	12	11	10	09	08	07	06
F	Not Used									

* Initial Value

6.4 SYSTEM Mode (Sn) Constants (Continued)

Sn-38 Programming Example

A particular application requires five-step speed control, upper limit input (N/C), lower limit input (N/C), and Load Float input. Since the five-step speed control requires the use of all the available terminals on the main terminal strip, the VGIN 10 option would be used.

Column 1 (Digit 4 selection) shows the available menus for the additional input functions. Choose one which provides all the required functions for the application. In this case, we choose data "7".

To begin the programming process (recall that x = 0 means disable; x = 1 means enable): We enable TC2, TC4, TC5 and TC9. All other terminals are disabled (See Page 56 for binary to hexadecimal conversion table)

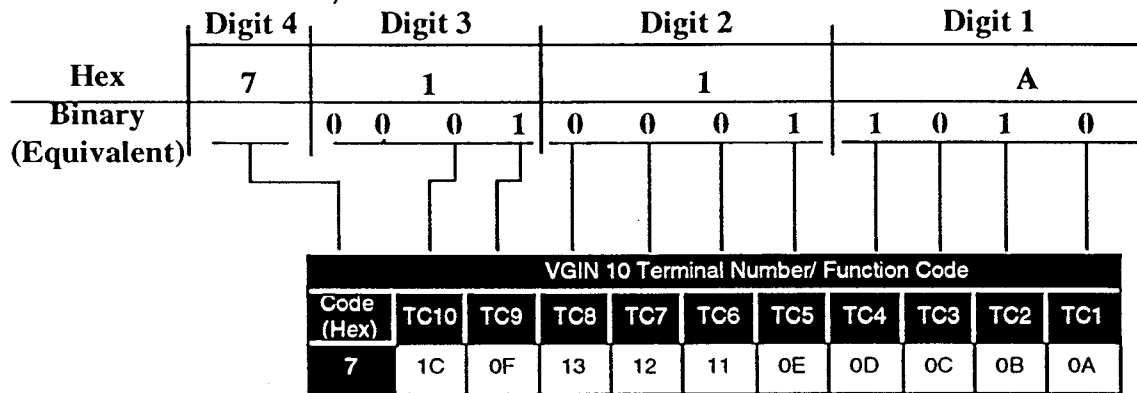

Sn-38 program data for this application is "711A".

Partial Re-print of Sn-15 - 18 Multi-Function Input Data (only these data (functions) are available by VGIN-10)	
Data	Description
06	Upper Limit 1 (Slow to An-01 by Bn-12) (N/O Contact)
07	Upper Limit 2 (Stop by Bn-12) (N/O Contact)
08	Lower Limit 1 (Slow to An-01 by Bn-12) (N/O Contact)
09	Lower Limit 2 (Stop by Bn-12) (N/O Contact)
0A	Upper Limit 1 (Slow to An-01 by Bn-12) (N/C Contact)
0B	Upper Limit 2 (Stop by Bn-12) (N/C Contact)
0C	Lower Limit 1 (Slow to An-01 by Bn-12) (N/C Contact)
0D	Lower Limit 2 (Stop by Bn-12) (N/C Contact)
0E	Micro-Positioning Control Gain
0F	Load Float
10	Micro-Positioning Control Gain + Load Float
11	Ultra-Lift Enable
12	Torque Limit Acc/ Dec
13	Alternate Torque Limit
17	External Immediate Stop at Stop Command (N/O Contact)
1A	Aux. Analog Input Effective
1C	Fault Reset (N/O Contact)
1E	Alternate Speed Reference Upper Limit

6.5 CONTROL (Cn) Constants

Number	Name	Unit	Setting Range	Initial Value
Cn-01	Speed Feedback for Brake Failure Detection. Failure if Speed Feedback \geq Cn-01 * 0.1	0.01%	0.00 ~ 20.00	5.00
Cn-02	Speed Coincedence Level	0.01%	0.00 ~ 100.00	100.00
Cn-03	Speed Coincedence Detection Width	0.01%	0.00 ~ 100.00	2.00
Cn-04	Excessive Speed Deviation Level	0.01%	0.00 ~ 130.00	10.00
Cn-05	Speed Reference Input Limit	0.01%	20.00 ~ 109.22	100.00
Cn-06	Minimum Speed Reference	0.01%	0.00 ~ 20.00	2.00
Cn-07	ASR Output Lag Time	1mSec	0 ~ 500	4
Cn-08	Speed Limit Gain	0.01	0.00 ~ 3.00	1.00
Cn-09	Encoder Constant (PPR)	1ppr	0 ~ 6000	1024
Cn-10	Speed Limit Bias (Torque Control)	0.01%	0.00 ~ 109.22	0.00
Cn-11	Micro-Speed Gain	0.1	0.0 ~ 1.0	0.1
Cn-12	Operator Display Mode	1	00000~39999	00000
Cn-13	Feeder Resistance	0.1	0.0 ~ 5.0	0.0
Cn-14	Motor Overload Current (%FLA)	1%	50 ~ 200	110
Cn-15	Overload Detection Time	1 Sec	1 ~ 120	60
Cn-16	Overspeed Detection Level	1%	50 ~ 130	110
Cn-17	Undervoltage Detection Level	1Vdc	131~210/262~420	210/420
Cn-18	PG Disconnect time before Fault	0.01 Sec	0.00 ~ 2.00	0.30
Cn-19	Minimum time for Immediate Stop at Power Loss	0.01 Sec	0.00 ~ 2.00	2.00
Cn-20	No. of Re-Start Attempts	1	0 ~ 10	0
Cn-21	Stop Timer (Time at Load Float)	1 Sec	0.0 ~ 255	10
Cn-22	ASR Proportional Gain 2	1	0 ~ 300	20
Cn-23	Changeover Speed for Cn-22	0.01%	0.00 ~ 100.00	0.00
Cn-24	Load Float Gain level	1	0 ~ 100	5
Cn-25	Load Float Completion Width	1 ppr	0 ~ 16383	10
Cn-26	S-Curve Time 2	0.1 Sec	0.0 ~ 10.0	0.0
Cn-27	Torque Reference Lag Time	1mSec	0 ~ 10000	0
Cn-28	Motor Temperature Limit	1°C	0 ~ 200	80

6.5 CONTROL (Cn) Constants (Continued)

Number	Name	Unit	Setting Range	Initial Value
Cn-29	Alternate Torque Limit Gain	0.1	0.0 - 2.0	1.0
Cn-30	AI-14B Option Channel 1 Gain	0.1	0.0 - 1000.0	100.0
Cn-31	AI-14B Option Channel 2 Gain	0.1	0.0 - 1000.0	100.0
Cn-32	AI-14B Option Channel 3 Gain	0.1	0.0 - 1000.0	100.0
Cn-33	Desired Torque Detection Level 1	0.01%	0.00 - 300.00	100.00
Cn-34	Slack Cable Detection Torque Level	0.01%	0.00 - 300.00	100.00
Cn-35	Brake Release Mech. Time Constant at Start and Stop	0.01 Sec	0.00 - 10.00	0.30
Cn-36	Time for Torque to go to zero	1 mSec	20 - 5000	1000
Cn-37	BE1 Detect Guarantee Time/ Torque Build Up Time at Torque Proving Start (Upper Limit is Input)	1 mSec	0 - 1000	100
Cn-38	Brake Release Torque Level	0.01%	-300.00- +300.00	100.00
Cn-39	BE3 Detect Guarantee Timer	0.01 Sec	0.0 - 10.00	0.10
Cn-40	Svr Function Primary Delay Timer (Noisy Encoder Protection)	1 Unit	0 - 2000 (0 - 500mS)	70 (17.5mS)
Cn-41	Ultra-Lift Enabling Speed (%Dn-02)	0.01%	0.00 - 109.22	100.00
Cn-42	Ultra-Lift Delay Time	0.01 Sec	0.00 - 30.00	2.00
Cn-43	Max. Ultra-Lift Torque in Reverse N=100 (Dn-01/Dn-02)(Cn-43/Un-26) Where N = % of Dn-02	1 %	0 - 100	30
Cn-44	% Speed Limit of Ultra-Lift in Reverse RPM = Dn-01 + (Cn-44 (Dn-02 - Dn-01))	1 %	0 - 100	30

6.6 MOTOR (Dn) Constants

Number	Name	Unit	Setting Range	Initial Value
Dn-01	Specified RPM (Full Load Speed) (Ns)	1 RPM	100 ~ 6000	1750
Dn-02	Ultra-Lift Maximum Speed (Nt)	1 RPM	100 ~ 6000	1750
Dn-03	Number of Motor Poles (P)	2	2 ~ 32	4
Dn-04	No-Load Voltage (V10)	1 V	50 ~ 240	170
Dn-05	Motor Rated Secondary Current (I20)	0.01 A	0.00 ~ 655.35	Inverter Current • 0.3
Dn-06	Rated Slip Frequency (fso)	0.01 Hz	0.00 ~ 5.00	1.00
Dn-07	Exciting Current Reference (km)	0.1%	10.0 ~ 200.0	30.0
Dn-08	Primary Resistance (%rl)	0.1%	0.0 ~ 15.0	2.0
Dn-09	Leakage Coefficient (%l)	0.01%	0.00 ~ 50.00	20.00
Dn-10	Motor Iron Loss (%Wi)	0.1%	0.0 ~ 15.0	2.0
Dn-11	Motor Mechanical Loss (%Wm)	0.1%	0.0 ~ 10.0	0.5
Dn-12	Secondary Circuit Time Constant (t2)	1 mSec	0 ~ 200	100
Dn-13	Leakage Saturation Coefficient (Kl)	0.01 pu	1.00 ~ 2.00	1.20
Dn-14	Rotor Heat Gain (Kthe)	0.01 pu	0.00 ~ 2.00	0.00
Dn-15	Rotor Heat Time Constant (Tr)	1 Min	0 ~ 180	30
Dn-16	Iron Core Saturation Coefficient (Ksi)	0.01 pu	0.00 ~ 1.00	0.50
Dn-17	Iron Core Saturation co. 2 (Ks2)	0.01 pu	0.00 ~ 1.00	0.75
Dn-18	Motor Overheat Temperature	1°C	50 ~ 200	150

6.7 MONITOR (Un) Constants

Number	Name	Description
Un-01	Not Used	-
Un-02	Not Used	-
Un-03	Output Current	Inverter Output Current is Displayed in AMPS
Un-04	Voltage Ref.	Inverter Output Voltage is Displayed in Volts (AC)
Un-05	DC Voltage	DC Bus Voltage is Displayed in Volts (DC)
Un-06	Not Used	-
Un-07	Input Term Status	<p>Sequence Input Terminal Status is Displayed as Below:</p> <p>Terminal 1 Terminal 2 Terminal 3 Terminal 4 Terminal 5 Terminal 6 Terminal 7 Terminal 8</p>
Un-08	Output Term Status VGOUT Card	<p>Sequence Output Terminals Status is Displayed as Below:</p> <p>Terminals 9 - 10 (VGOUT 1) Terminals 25 - 27 (VGOUT 2) Terminals 26 - 27 (VGOUT 3) Terminals 28 - 29 (VGOUT 4) Terminals 29 - 27 (VGOUT 5)</p>
Un-09	LED Check	All LEDs on the Digital Operator are lit-Integrity Check
Un-10	Control Sec. Soft #	Control Section EPROM Software Version is Displayed
Un-11	Option Sec. Soft #	Option Section EPROM Software Version is Displayed
Un-12	Input Term VGIN Card	<p>VGIN10 Input Terminal Status is Displayed as Below:</p> <p>VGIN10-1 VGIN10-2 VGIN10-3 VGIN10-4 VGIN10-5 VGIN10-6 VGIN10-7 VGIN10-8 VGIN10-9 VGIN10-10</p>

6.7 MONITOR (Un) Constants (Continued)

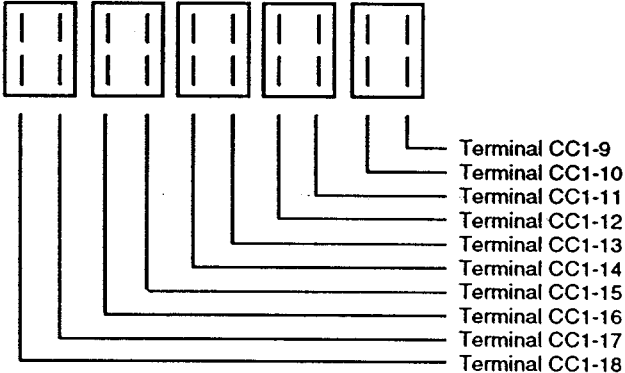
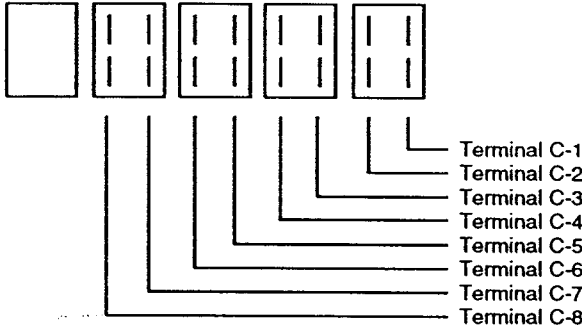
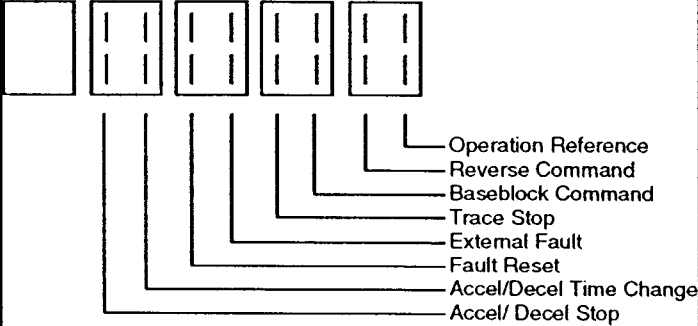
Number	Name	Description
Un-13	Input Term (DI-16H)	<p>DI-16 Input Terminal Status is Displayed as Below:</p> 
Un-14	Output Term (DO-8)	<p>DO-8 Output Terminals Status is Displayed as Below:</p> 
Un-15	Master Command 1	<p>Inverter Commands are Displayed as Below:</p> 

6.7 MONITOR (Un) Constants (Continued)

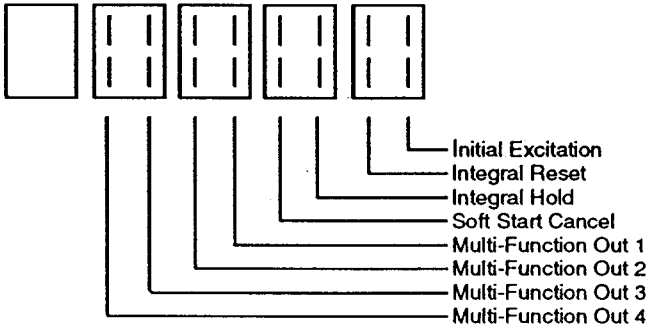
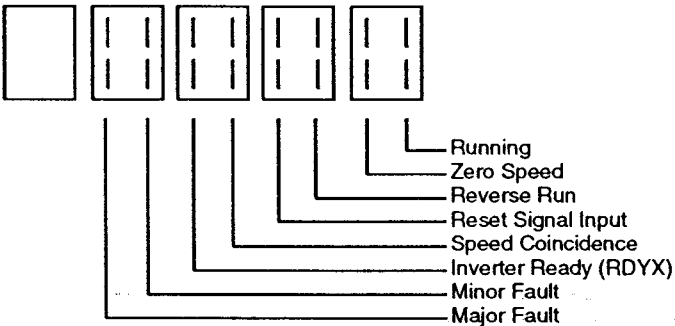
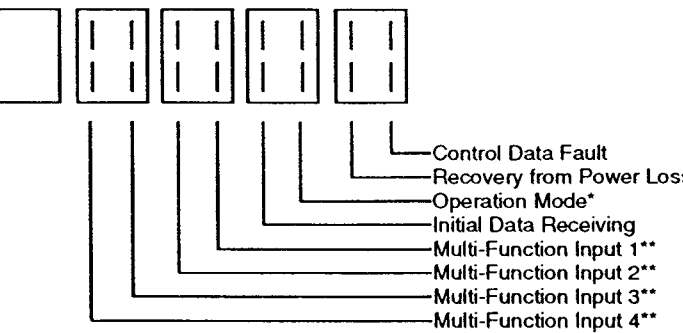
Number	Name	Description
Un-16	Master Command 2	<p>Inverter Commands are Displayed as Below:</p> 
Un-17	Status 1	<p>Inverter Control Status is Displayed as Below:</p> 
Un-18	Status 2	<p>Inverter Control Status is Displayed as Below:</p> 

6.7 MONITOR (Un) Constants (Continued)

Number	Name	Description
Un-19	Not Used	-
Un-20	Not Used	-
Un-21	Speed Ref. (SFS In)	Speed Reference in a stage before Soft-Start is displayed. % display for Motor Rated (maximum) RPM.
Un-22	Speed Ref. (SFS Out)	Speed Reference in a stage before Soft-Start is displayed. % display for Motor Rated (maximum) RPM.
Un-23	Speed Feedback	Motor Actual Speed (Speed Feedback) is displayed. % display for Motor Rated (maximum) RPM.
Un-24	Ext. Torque Ref.	Torque Reference at Torque Control is displayed. % display for Motor Rated Torque.
Un-25	Torque Feedback	Torque Compensation is displayed. % display for Motor Rated Torque.
Un-26	Int. Torque Feedback	Internal Torque Reference. A value obtained by multiplying secondary current reference value by magnetic flux reference value is displayed at speed control mode. % display for Motor Rated Torque.
Un-27	Torque Feedback	Motor Torque Operated Value. Displayed only when Option Card (Torque Detector) is applied.
Un-28	AR Input (Spd. Dev.)	Deviation between Speed reference (Soft-Start latter stage) and actual speed feedback is displayed. % display for Motor Rated (maximum) RPM.
Un-29	ASR Output	Speed Controller (ASR) output is displayed. This Value becomes motor secondary current reference value. % display for Motor Rated Secondary Current.
Un-30	Slip Freq. Ref.	Motor Slip Frequency Reference. % display for Motor Rated Slip Frequency.
Un-31	Primary Freq. Ref.	Inverter Output Frequency. % display for Motor Rated Synchronous Frequency.
Un-32	Motor Temperature	Motor Stator Temperature is displayed.
Un-33	Zero-Servo Error	Number pulses moving from Zero-Servo Start point.
Un-34	Inverter A/D Volts	Inverter Main Speed A/D input voltage.
Un-35	Aux. A/D Volts	Inverter Auxiliary A/D Input Voltage
Un-36	AI-14B Ch.1 Volts	AI-14B Chanel 1 Input Voltage
Un-37	AI-14B Ch.2 Volts	AI-14B Chanel 2 Input Voltage
Un-38	AI-14B Ch.3 Volts	AI-14B Chanel 3 Input Voltage
Un-39	Magnetic Flux A	Magnetic Flux Feedback (Phase α)
Un-40	Magnetic Flux B	Magnetic Flux Feedback (Phase β)
Un-41	ACR Compensation	ACR Compensation Value

6.8 Order (On) Constants

Number	Name	Digit Number	Data/Increment	Remarks/Function	Initial Value	Data Range				
On-01	Control Status 1	1, 2, 3	000 *	Normal Operation	0000	0000-1111				
			010	Simulation Mode (PUV NOT provided)						
			011	Base Test Mode						
			100	V/F Test Mode						
		4	0 *	PG Disconnection Protection is Provided						
			1	PG Disconnection Protection is NOT Provided						
On-02	Control Status 2	1	0 *	Vector Control WITH PG	0010	0000-1111				
			1	Vector Control WITHOUT PG						
		2	0	Thermistor is Installed in Motor (Adaptive Control)						
			1 *	Thermistor is NOT Installed in Motor						
		3	0 *	Rotor Heat Model is Effective						
			1	Rotor Heat Model is NOT Effective						
		4	0 *	TRQ-A is Installed and Effective						
			1	TRQ-A is NOT Effective						
		On-03	Control Status 3	1			0 *	Phase at Initial Excitation is Fixed	1010	0000-1111
							1	Phase at Initial Excitation is Detected		
2	0			Field Forcing is Provided						
	1 *			Field Forcing is NOT Provided						
3	0 *			Overvoltage Control Function is NOT Provided						
	1			Overvoltage Control Function IS Provided						
4	0			DSP A/D Automatic Offset Adjustment IS Provided						
	1 *			DSP A/D Auto Offset is NOT Provided						
On-04	Control Status 4			1	0 *	Not Used - Data MUST be "0"	0000	0000		
					1					
		2	0 *	Not Used - Data MUST be "0"						
			1							
		3	0 *	Not Used - Data MUST be "0"						
			1							
		4	0 *	Not Used - Data MUST be "0"						
			1							

* Initial Value

6.8 Order (On) Constants (Continued)

Number	Name	Unit	Setting Range	Initial Value
On-05	Inverter Low Frequency OL Gain	0.1 p.u.	1.0 ~ 5.0	by Sn-01
On-06	Inverter Low Frequency OL Freq.	0.01 Hz	0.00 ~ 5.00	by Sn-01
On-07	Regen Side Torque Limit at Low Freq.	0.01%	0.00 ~ 300.00	50.00
On-08	Current Amplifier Characteristics	1 (Code)	000 ~ 254	020
On-09	ASR Output Advance Time (Only for Multi-Systems with PG)	1mSec	0 ~ 500	0
On-10	CEMF Compensation	0.001 p.u.	0.000 ~ 1.300	1.000
On-11	AøR Time Constant	1mSec	200 ~ 2000	by Sn-02
On-12	AFR Gain (without PG)	0.01p.u.	0.00 ~ 2.00	1.00
On-13	AFR Time Constant (without PG)	1mSec	50 ~ 2000	120
On-14	Magnetic Flux Feedback Gain	0.001p.u.	0.800 ~ 1.200	1.000
On-15	Current Feedback Gain	0.001p.u.	0.800 ~ 1.200	1.000
On-16	NV-RAM Soft Number	1 (Code)	0 ~ 9999	Program No.
On-17	DSP A/D Converter Phase U Gain	0.0001p.u.	0.9000 ~ 1.1000	1.0000
On-18	DSP A/D Converter Phase U Offset	1	-819 ~ +819	0
On-19	DSP A/D Converter Phase W Gain	0.0001p.u.	0.9000 ~ 1.1000	1.0000
On-20	DSP A/D Converter Phase W Offset	1	-819 ~ +819	0
On-21	On-Delay Compensation Gain	0.01p.u.	0.00 ~ 2.00	1.00
On-22	Not Used	--	--	--
On-23	Not Used	--	--	--
On-24	Not Used	--	--	--
On-25	Not Used	--	--	--

Section 7: Start-Up

Caution: Personnel should be aware of the potential hazards and the appropriate safety considerations.

This section assumes that the IMPULSE•VG+ has been wired as specified in Section 3, and that the motor's Dn parameters are known and programmed. If you have purchased the motor from Electromotive Systems, the motor parameters are already programmed into the IMPULSE•VG+.

7.1 Power Off Checks

- Check to make sure the motor is connected to the inverter output terminals (T1, T2, T3), and that the motor encoder is connected to the PG-T card as specified in Section 3.
- Check to make sure the incoming three-phase power wiring is connected to terminals L1, L2, and L3. **Connection of this incoming power to the inverter output terminals (T1, T2, T3) will result in unit damage.**
- Check to make sure the incoming power to the inverter is within allowable tolerances:
230 Volt units: 180 VAC - 253 VAC
460 Volt units: 342 VAC - 506 VAC
- Check to be sure there are no loose electrical connections.
- Check to be sure there is no debris inside of the IMPULSE•VG+ enclosure.
- 460 Volt units 15 Hp and above: Make sure the voltage selector jumper plug is in the correct position (see Section 3.1.5).
- All CDBR units: ~~Make sure the voltage selector jumper plug is in the correct position (see Section 3.2.3).~~

7.2 Initial Power Up

Apply the input power. You will hear a faint click as the main circuit contactor within the drive energizes.

You should see the keypad illuminate within one second, indicating the logic power supply is within specification. Keypad will display "00.0". The initial display of the digital operator is set by data of Bn-13. (The initial value is "2").

The CHARGE LED will light within one second, indicating the main DC bus capacitors are charged to a voltage greater than 50 VDC.

Check the program data to make sure it matches the documentation. Also check Cn-09 to be sure it matches the PPR rating of your encoder.

7.3 Factory Default Settings

When the IMPULSE•VG+ was shipped, it was set up for hoisting operation. These initial settings should allow you to operate the typical vector motor (induction motor with encoder) without any adjustments.

7.4 Which Way is Up?

The hoist must operate in the up direction when the IMPULSE•VG+ is provided with a Run forward command (120 VAC to VGIF Terminal 1). The motor/encoder must be matched with the IMPULSE•VG+ for direction. The motor must also provide up operation (mechanically) when given the Run Forward Command.

7.4.1 Rotation Check Procedure

CAUTION: Be prepared to immediately remove power in the event of unexpected operation. If the encoder count (Cn-09) is programmed incorrectly, or if the direction of rotation is backwards, the unit may not stop when the Run command is removed.

1. Make sure personnel are clear of all mechanical and electrical equipment.
2. Make sure that the motor is de-coupled from the other hoist equipment (gearbox, drum, etc.)
3. Make sure that An-01 is set for no more than 10% speed.
4. Set the keypad to display actual speed feedback (no "n" prefix shown).
5. Make sure the direction LED on the digital operator indicates forward direction (if not press "Fwd/Rev" button on keypad).
6. Briefly press and hold the "RUN" button of the digital operator until the motor begins to rotate.
7. Make sure that the display indicates a positive (+) value.
8. Make sure that the direction of motor rotation will provide up hoisting motion when coupled to the drum.
9. If rotation is incorrect (speed indication is negative (-)), remove power from the IMPULSE•VG+, wait for the red charge lamp to go out, and swap any two motor leads (T1, T2 or T3) at the output of the IMPULSE•VG+.
10. Repeat steps 1 through 9 again.

The flow chart on the next two pages is provided to assist the rotation check procedure.

7.4.1 Rotation Check Flow Chart

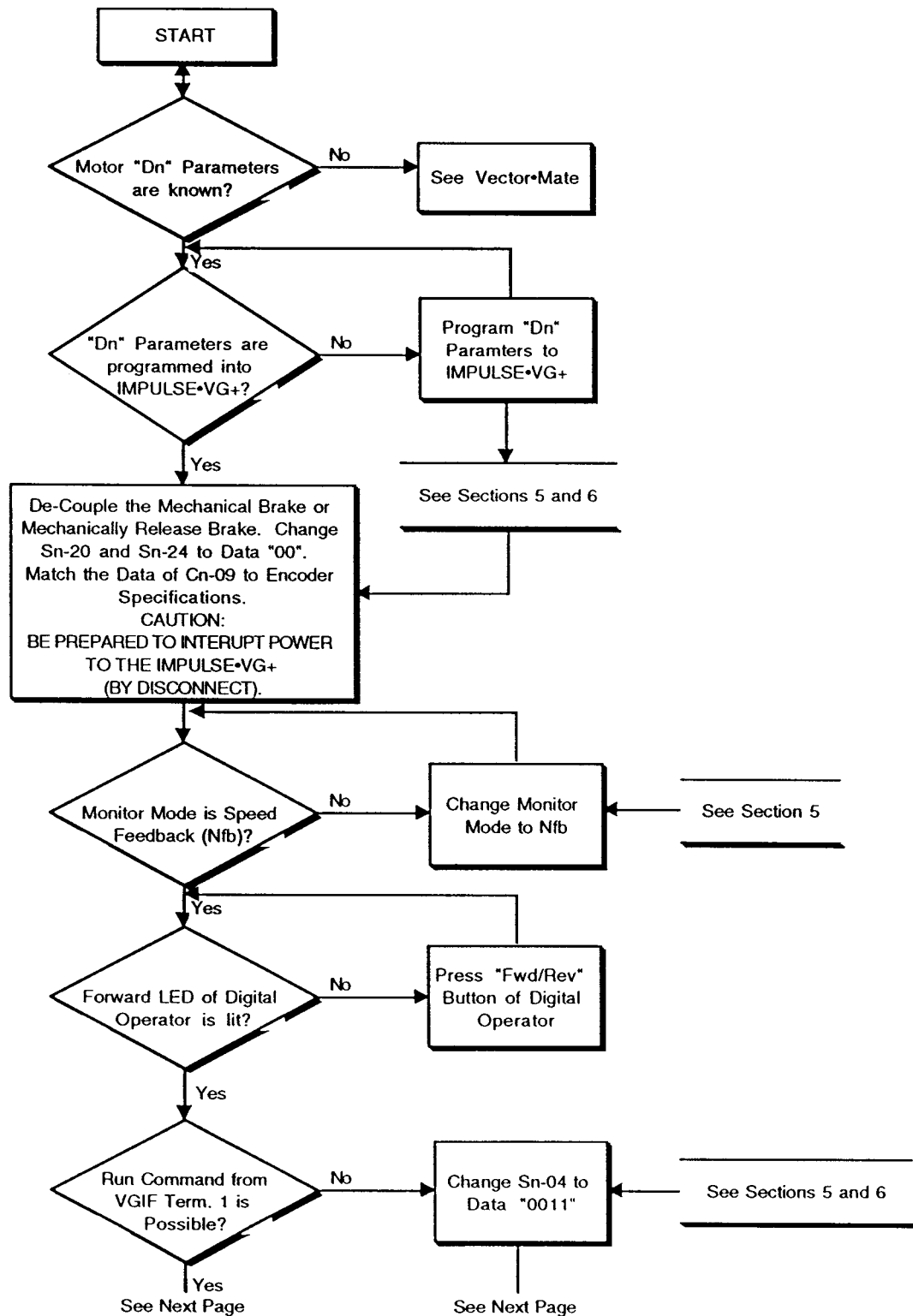

7.4.1 Rotation Check Flow Chart (Continued)

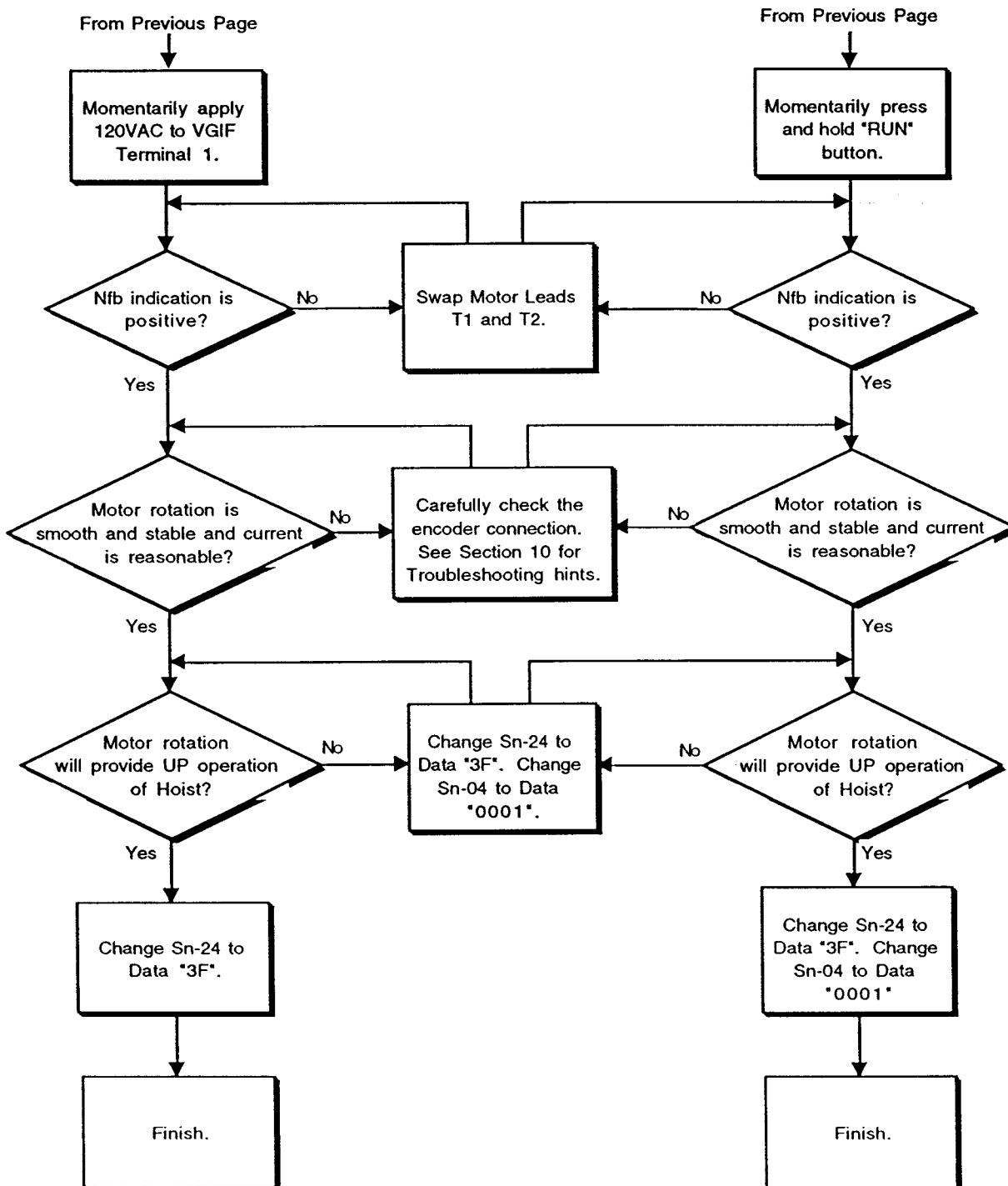

7.5 Setting the Speed Control Method

After following the set-up in the preceding section, the IMPULSE•VG+ and motor are now operational. You must now select the control method. The software offers a variety of speed control methods including:

- Multi-step speed control method (up to five speeds by contact input).
- Infinitely variable speed control method by contact input.
- Infinitely variable speed control method by analog input (Joystick control).

Standard parameter setting by Electromotive Systems provides for five-step multi-step speed control method. If five-step method is acceptable, proceed to section 7.6.

7.5.1 Speed Control Mode Selection Flow Chart

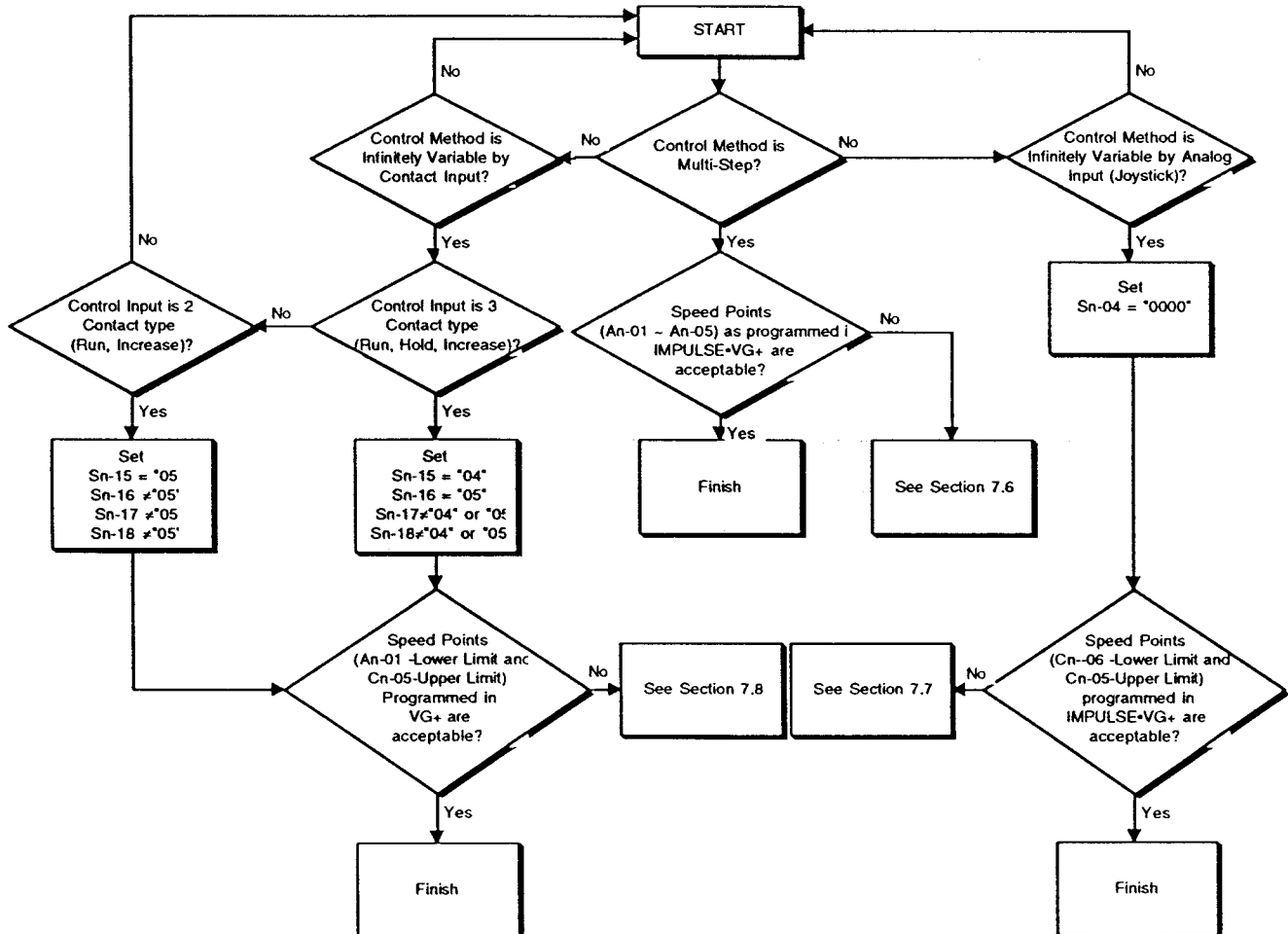

7.6 Setting the Speeds in Multi-Step Method

This section applies only to multi-speed method, and provides guidance for setting the output speed of each of the available five steps. Below is a shortened reprint of the An parameter chart found earlier in this publication:

Number	Name	Increment	Setting Range	Initial Value
An-01	Speed 1/Lower Limit	0.01%	0.00 ~ 100.00%	10.00%
An-02	Multi-Step Speed 2	0.01%	0.00 ~ 100.00%	25.00%
An-03	Multi-Step Speed 3	0.01%	0.00 ~ 100.00%	50.00%
An-04	Multi-Step Speed 4	0.01%	0.00 ~ 100.00%	75.00%
An-05	Multi-Step Speed 5	0.01%	0.00 ~ 100.00%	100.00%

The speed settings of An-01 ~ An-05 are set as a percentage of the motor's normal nameplate speed (per Dn-01). For example, if the motor nameplate speed is "1750", a set data of 10.00% will yield a speed of 175RPM.

Determine what speeds are required (as a percentage of motor nameplate speed) and program to IMPULSE•VG+.

7.7 Infinitely Variable Mode/Analog Input: Upper and Lower Limit

This section applies only to the Analog types of infinitely variable speed control methods (0-10VDC analog type or ± 10 VDC analog type), and provides guidance for setting the lower and upper speed reference limits. Below is a shortened reprint of the appropriate constant charts found earlier in this publication:

Number	Name	Unit	Setting Range	Initial Value
Cn-05	Speed Reference Input Limit	0.01%	20.00 ~ 109.22	100.00
Cn-06	Minimum Speed Reference	0.01%	0.00 ~ 20.00	2.00

The data of Cn-05 and Cn-06 are set as a percentage of the motor's normal nameplate speed (per Dn-01). For example, if the motor nameplate speed is "1750", a set data of 10.00% for Cn-06 (Lower Limit) will yield a minimum operating speed of 175RPM.

Determine what minimum and maximum speeds are required (as a percentage of motor nameplate speed) and program to IMPULSE•VG+.

7.8 Infinitely Variable Mode/Digital Input: Upper and Lower Limit

This section applies only to the Digital types of infinitely variable speed control methods (two-step and three-step contact input types), and provides guidance for setting the lower and upper speed reference limits. Below is a shortened reprint of the appropriate constant charts found earlier in this publication:

Number	Name	Unit	Setting Range	Initial Value
An-01	Speed 1/Lower Limit	0.01%	0.00 ~ 100.00	10.00
Cn-05	Maximum Speed Reference/ Upper Limit	0.01%	20.00 ~ 109.22	100.00

The data of An-01 and Cn-05 are set as a percentage of the motor's normal nameplate speed (per Dn-01).

For example, if the motor nameplate speed is "1750", a set data of 10.00% for An-01 (Lower Limit) will yield a minimum operating speed of 175RPM.

Determine what minimum and maximum speeds are required (as a percentage of motor nameplate speed) and program to IMPULSE•VG+.

7.9 Test Run on the Hoist

From the proceeding sections, the IMPULSE•VG+ and the motor/brake are now ready for mechanical connection to the hoist:

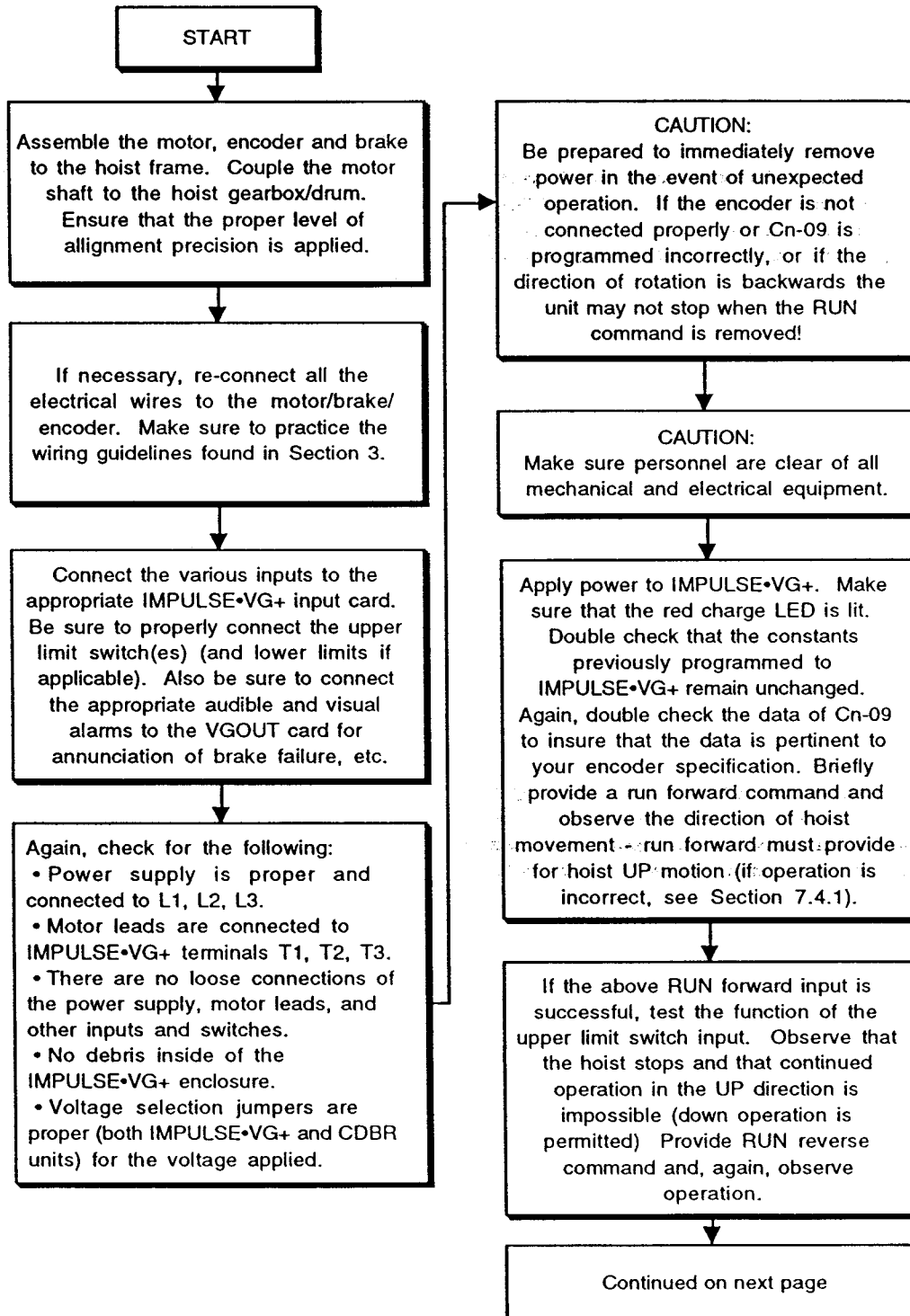

7.10 Test Run (Continued)

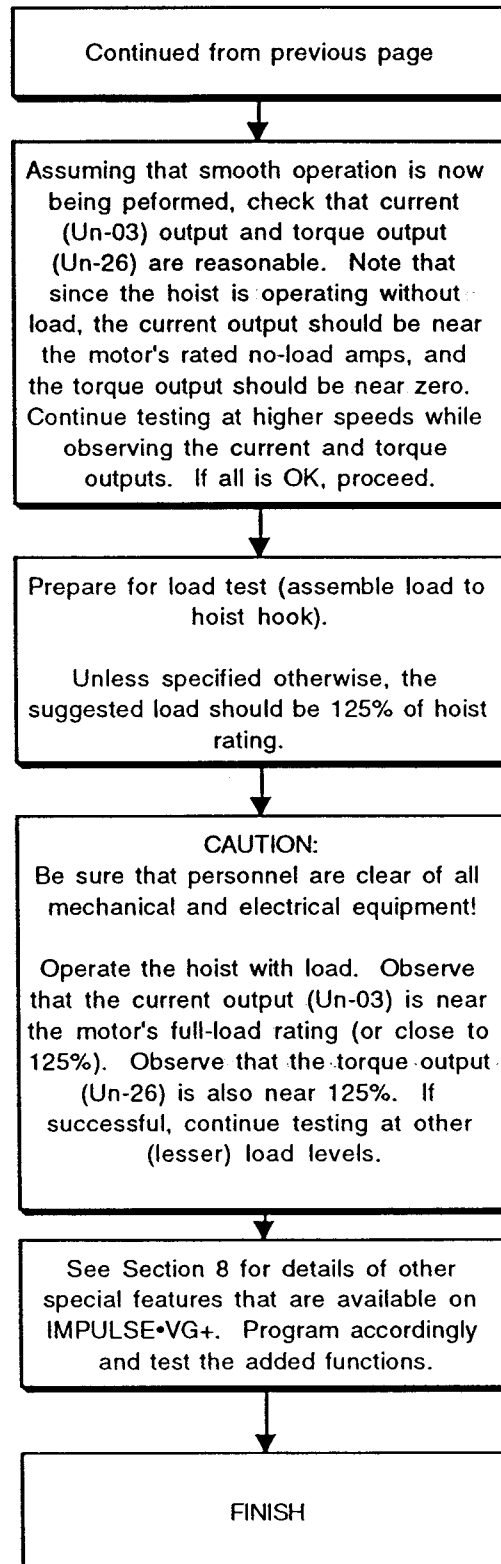

Section 8: Traverse Applications

The benefits of IMPULSE•VG+ are not limited to hoisting applications. IMPULSE•VG+ can also be applied to various traverse applications to provide the following possible benefits:

- Speed range of 1000 to 1.
- Torque limiting functions to improve mechanical reliability.
- Two (or more) motor applications requiring load sharing.

IMPULSE•VG+ is appropriate for:

- Trolley drives
- Bridge drives
- Dual motor gantry drives (load sharing)
- Bucket cranes (both hoisting and horizontal modes)

This section will address the programming requirements and electrical hook-ups required for horizontal applications (both single motor and multi-motor).

8.1 Single Motor Horizontal Applications (Trolley and Bridge)

The sophisticated starting and stopping sequences necessary for hoisting applications are not essential to traverse motions. The various timers and counters needed for hoisting are superfluous for bridge and trolley motions. In addition, under certain circumstances, they can detract from the responsiveness of the driven equipment. IMPULSE•VG+ has the flexibility to "program out" these unnecessary components. See Section 8.1.1 for the necessary program changes to ensure trouble-free traverse motion.

8.1.1 Program Changes for Traverse Motions (Single Motor Only)

Program Changes for Horizontal Applications (Single Motor Type)			
Constant No.	Hoisting Data	Horizontal Motion Data	Remarks
Sn-18	03	37	Enables "Torque Proving" mode. *Note1
Cn-38	100.00	0.00	Eliminates the delay of Torque build-up. Enables the brake output immediately upon Run command. *Note 2
<p>*Note 1: When using the IMPULSE•VG+ in Torque Proving mode, a brake answer-back signal is required for successful operation. The input of the brake answer is simulated by a jumper from terminal 10 of the IMPULSE•VG+ logic card (see connection diagram) going to terminal 8 of the VGIF input card. Since this same terminal 8 is applied for the 5th step of multi-step control, the input sequence of the 5th step must be changed (See Multi-Step Speed Control Operation Table for Horizontal Applications). Note that all the other speed control modes operate as previously described in this manual.</p>			
<p>*Note 2: Certain applications require that some level of torque be output prior to brake release (gantry cranes operating on uneven terrain, shipboard cranes subject to heavy winds, etc). To meet the demands of your application, Cn-38 can be programmed to a higher value. This will insure that no inadvertent movement occurs during the short time between brake release and torque build-up (generally ≤ 300mSecs). Note that while operating in "Torque Proving" mode, the brake is released only after the torque value of Cn-38 is already achieved.</p>			

8.1.1.1 Traverse Application Multi-Step Operation Table

Traverse Application (when Sn-18 = 37 only)--Multi-Step Speed Control Operation Chart				
Input to VGIF Card				ACTION (SPEED REFERENCE)
VGIF Terminal 1 (2)	VGIF Terminal 5	VGIF Terminal 6	VGIF Terminal 7	
O	-	-	-	STOP
X	O	O	O	Runs Forward (Reverse) at speed of An-01
X	X	O	O	Runs Forward (Reverse) at speed of An-02
X	X	X	O	Runs Forward (Reverse) at speed of An-03
X	X	X	X	Runs Forward (Reverse) at speed of An-04
X	O	X	X	Runs Forward (Reverse) at speed of An-07
O = Open, X = Closed, - = Not Applicable				

8.1.2 Traverse Application Control Section Connections

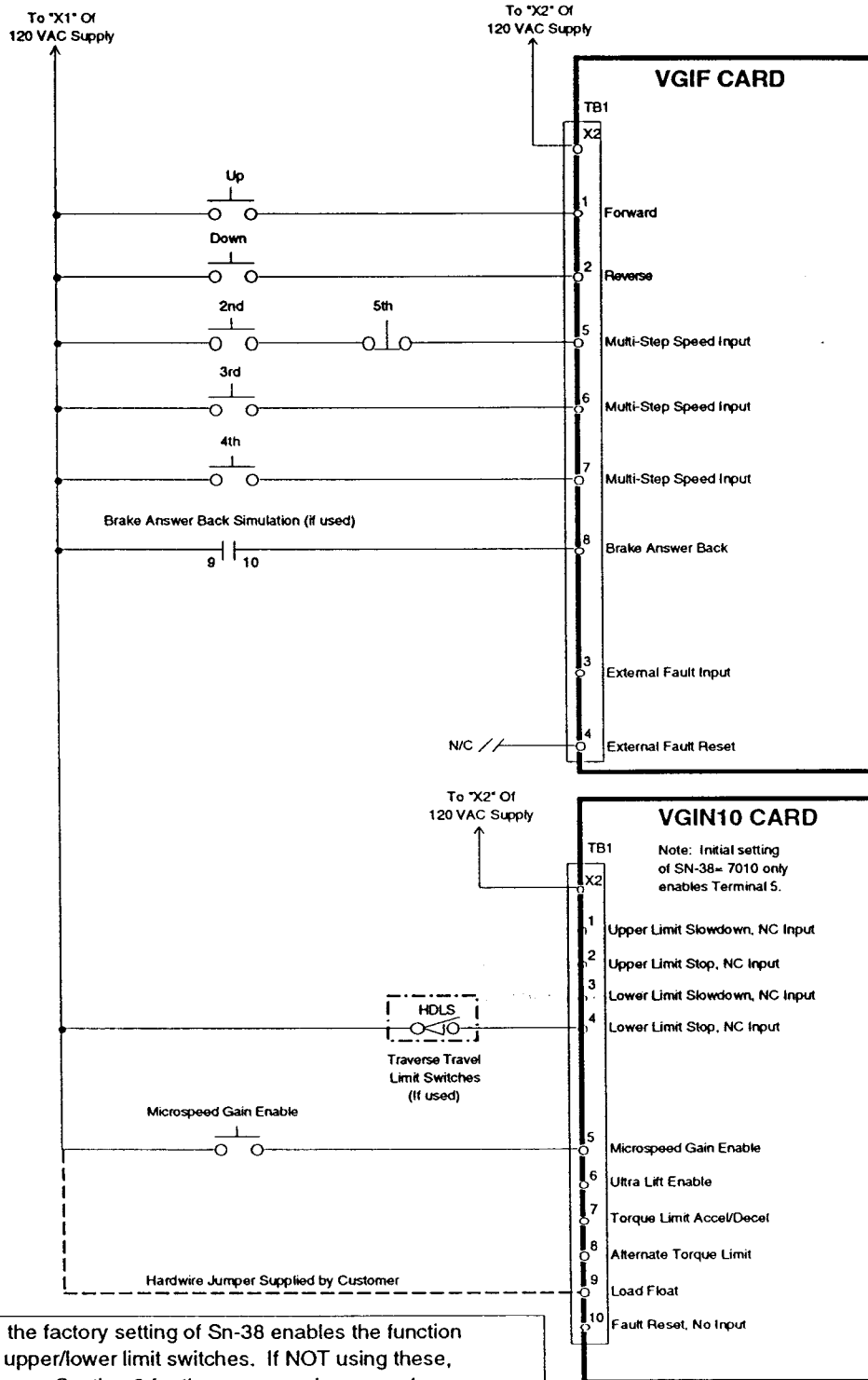

Note: the factory setting of Sn-38 enables the function of the upper/lower limit switches. If NOT using these, please see Section 6 for the programming procedure to enable the respective terminals.

8.1.2 Traverse Application Control Section Connections (Continued)

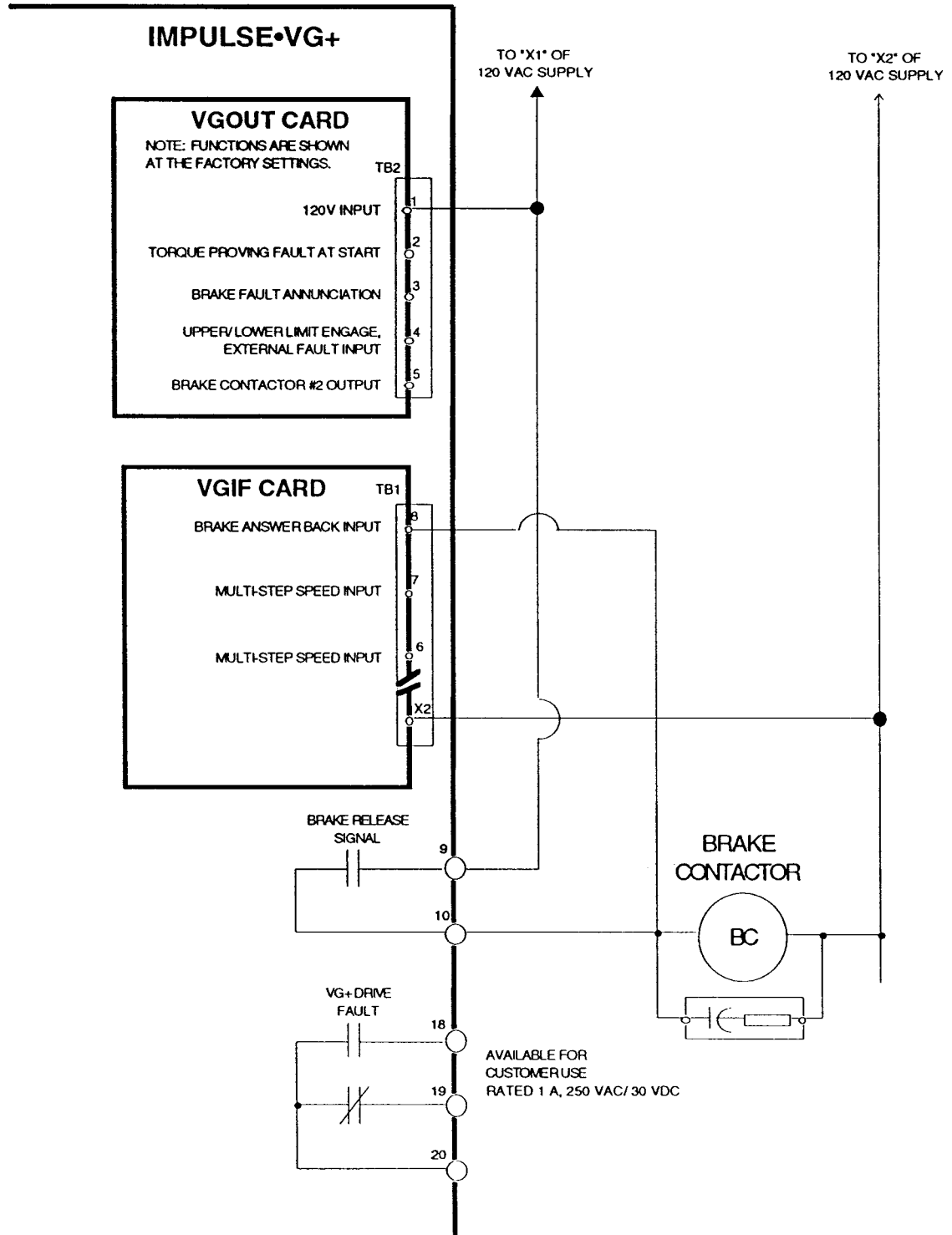

8.2 Dual Motor Traverse Applications (Load Sharing)

IMPULSE•VG+ can provide true load sharing capabilities for dual motor bridge, gantry and trolley applications.

8.2.1 Program Changes for Dual Motor Traverse Applications

Program Changes for Dual Motor Traverse Applications			
Constant No.	Master Data	Slave Data	Remark
An-01–An-09	-	- *	* Slave Data must be Master x 1.1 (10% higher)
Bn-01	8.0	7.3	Slave Data = Master Data/ Speed Gain (If Speed Control is by Analog Input ,Speed Gain is Bn-10). If Speed Control is by An reference, the Slave Data = Master Data/(Slave An/ Master An)
Bn-02	10.0	9.1	
Bn-03	10.0	9.1	
Bn-04	10.0	9.1	
Bn-06	800	0	Eliminate the Slaves' Integral Time of PI Speed Controller Function
Bn-10	1.0000	1.1000	When Analog Speed Reference is used, the Speed Gain of Slave is 110%. Note that Bn-10 does NOT effect the An constants.
Bn-12	10.0	9.1	See Bn-01 - Bn-04 Remark.
Bn-17	26	-	Torque Reference Output (to input to Slave AI-14B, Channel #2)
Bn-18	0.500	-	Torque Reference is Scaled to 5V/100%
Bn-22	26	-	If AO-12 is used for Torque Reference Output to Slave
Bn-23	0.500	-	Torque Reference is Scaled to 5V/100%
Sn-18	37	37	Brake Feedback Signal is Input to Term. 8 (Enables Torque Proving Mode)(if used)
Sn-20	00	00	Enables Torque Proving Mode (if Sn-18 = 37)
Sn-24	00	00	PHC output is for Input to Term. 8 (Brake Feedback)
Sn-25	0000	0011	Enables Torque Limit Operation by Channel 2 (Speed Reference by Channel 1)
Sn-38	711A	711A	Enables Load Float, Micro-Positioning Control Gain, Upper Limit 1 and 2, Lower Limit 1 and 2
Cn-30	100.0	110.0	If AI-14B Channel 1 is used for Slave Speed Reference the Gain is Set to 110%
Cn-31	100.0	100.0	Do Not Change for Proper Scaling
Cn-38	0.00	0.00	Torque Output for Brake Release--Data 0.00 essentially disables Torque Proving at Start

8.2.2 Dual Motor Application Control Section Connections

The majority of connections for dual motor applications are identical to that of a single motor system. For connections to the VGIF and VGIN input cards, please refer to section 8.1.2. Note that commands for Run, Multi-Step speed, Load Float, etc. should be input simultaneously to both the master and slave drives.

Additional communication between the master and slave is necessary. The master drive is programmed to provide an output proportional to its output torque. This signal is input to the slave drive to determine its output torque. With this connection completed, both drives will produce exactly the same torque, providing absolute load sharing between the master and slave drives and motors.

Connection of the communication link between master and slave is as below: .

Note: Other connections are identical to single drive system (see Section 8.1.2).

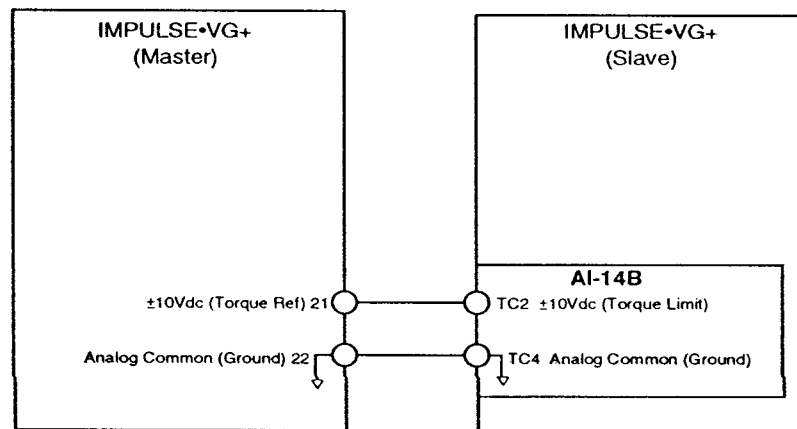

Section 9: Special Features

This section explains the special software functions of IMPULSE•VG+.

9.1 Standard Safety Functions (not specifically enabled) of IMPULSE•VG+

IMPULSE•VG+ is a unique combination of hardware and software specifically designed for extremely demanding overhead material handling industry. IMPULSE•VG+ offers some unique functions that help achieve the highest level of performance and safety for these applications. Section 9.1 describes these functions.

9.1.1 STOP Key (of Digital Operator) Operation

Due to the unique requirements of overhead material handling applications, a drive for a hoist or crane must provide a higher level of safety. The STOP key is always enabled, and the initial value is programmed for immediate stop at key depression.

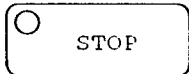

= ALWAYS Enabled, Operation is programmed by Sn-04, bits 2 and 3
Initial Value = Immediate STOP at key depression.

9.1.2 RUN Button Operation

To ensure safe operation of cranes and hoists in the local operation mode demands that operation only be possible when the RUN button is depressed (momentary operation). The absence of a RUN command demands STOP (according to the programmed stopping method, Sn-04 bits 2 and 3). This reduces the possibility of a runaway crane.

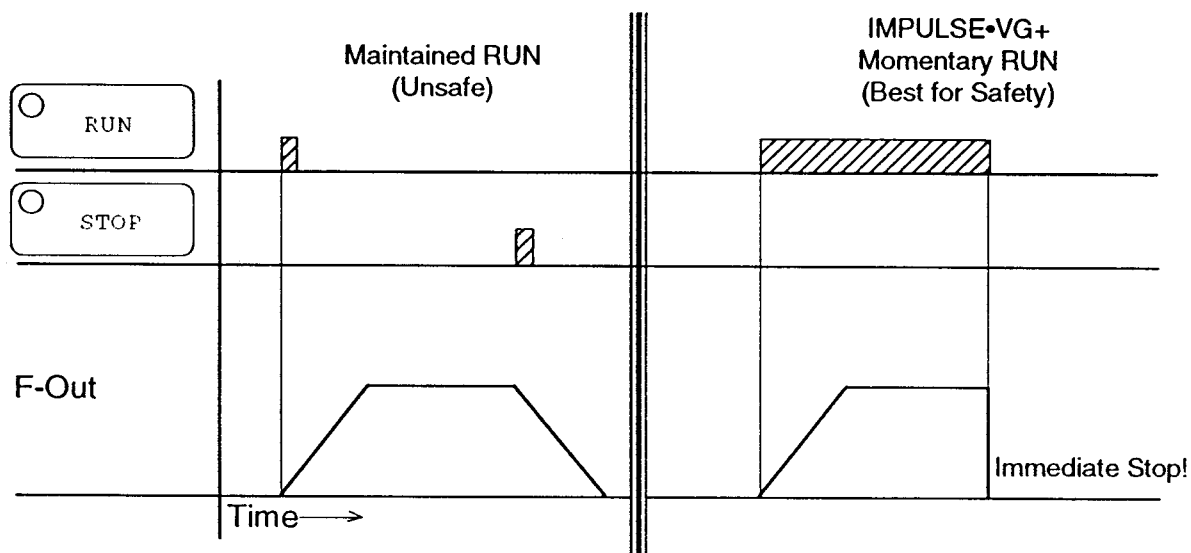

9.1.3 Phase Loss Detection

Phase Loss Detection compares the output current of each of the three phases to a pre-set level. If the output current of any of the phases falls below that pre-set level, an LF fault will appear on the display. Unlike conventional inverters in case of a phase loss, the IMPULSE•VG+ will immediately set the brake, retaining control of the load.

9.1.4 Fault Annunciation by PHC output (SSR output by VGOUT card)

The IMPULSE•VG+ permits the programming of specific output faults by specific output devices. These output signals are used to warn the operator of potentially dangerous conditions. Programming is required if the Electromotive Systems initial values are unsatisfactory for a particular application. Base programming is as below:

Sn-21~24 Fault Annunciation Programming Method and Example

Example: A certain application requires an alarm at all sequence (SE and BE type) faults. The table below shows that the correct data would be "67".

Hex	Digit 2		Digit 1					
	6	6	7	7	7	7	7	
Binary	0	1	1	0	0	1	1	1
Menu Select								
	Fault Annunciation							
Binary Code	0 = Fault is Not Output to PHC, 1 = Fault IS Output to PHC							
1 1	OS	DEV	LF	-	OL2	OL1		
1 0	UL2	UL1	LL2	LL1	LF	EF1		
0 1	BE6 SE6	-	-	BE3 SE3	BE2 SE2	BE1 SE1		

Conversion Chart		
Hexadecimal	Decimal	Binary
0	0	0000
1	1	0001
2	2	0010
3	3	0011
4	4	0100
5	5	0101
6	6	0110
7	7	0111
8	8	1000
9	9	1001
A	10	1010
B	11	1011
C	12	1100
D	13	1101
E	14	1110
F	15	1111

9.2 The Basic Hoisting Sequences

There are four basic hoisting sequences:

- Hoisting (up) start sequence at forward
- Lowering (down) start sequence at reverse
- Stopping sequence at forward and reverse
- Starting sequence when the upper limit is input

A timing chart for each of the sequences follows. For more information, please contact Electromotive Systems' Engineering Department by phone at 414/783-3500 or by fax at 414/783-3510.

9.2.1 Normal Operation Start Sequence (Brake Proving Type)

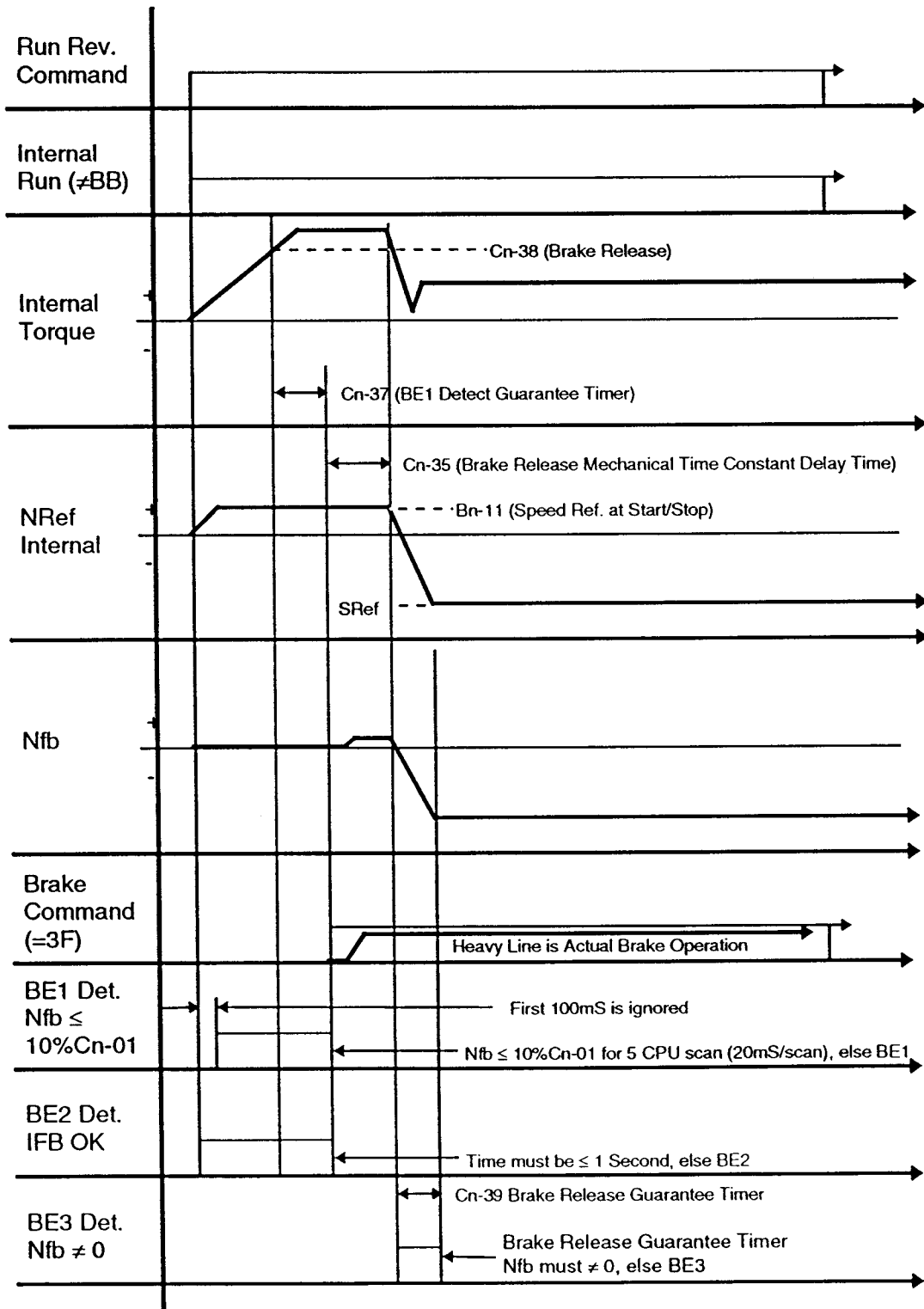

9.2.2 Start Sequence When Upper Limit is Input (Torque Proving Type)

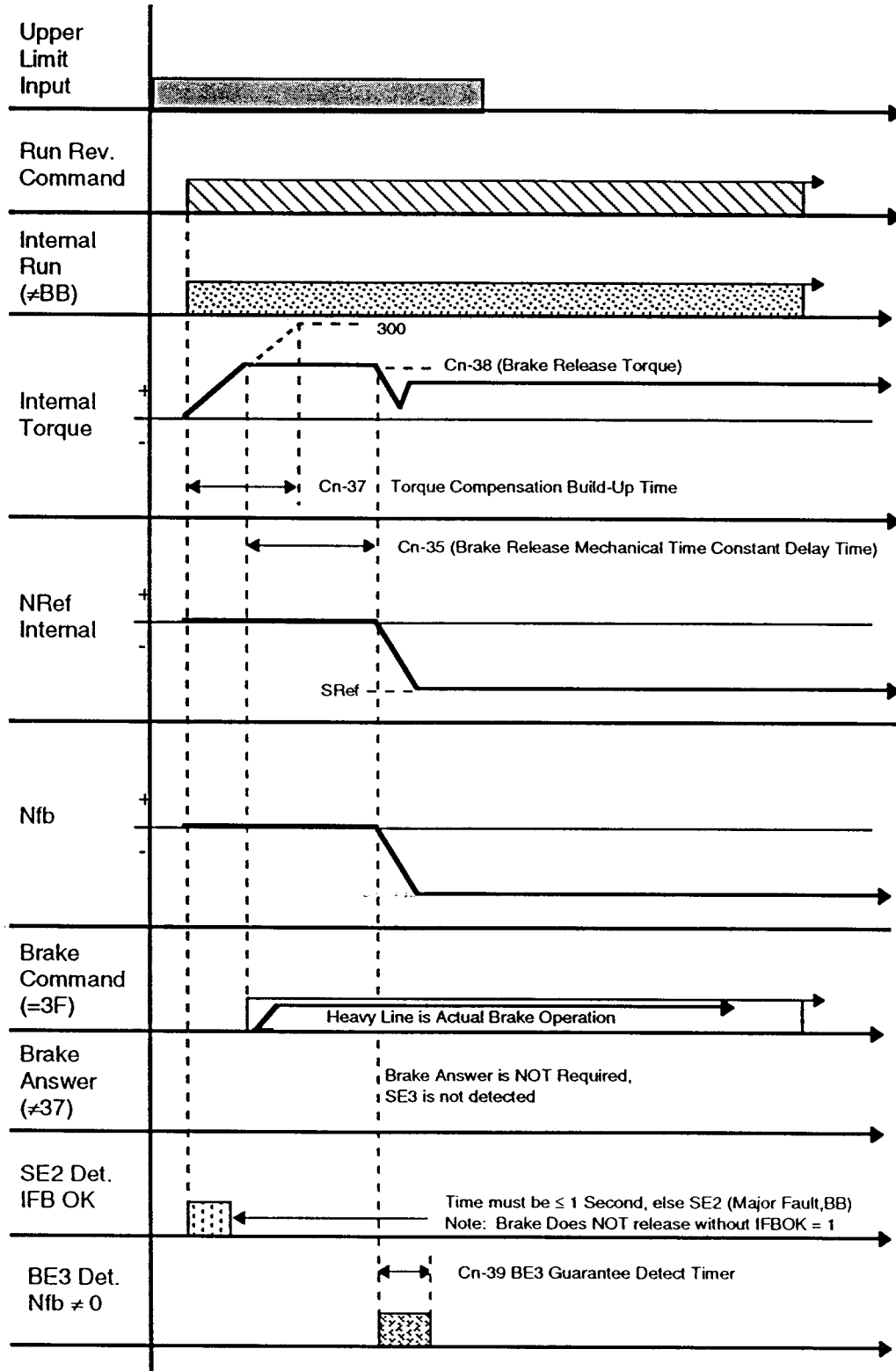

9.2.3 Normal Operation Stop Sequence (Brake Proving Type)

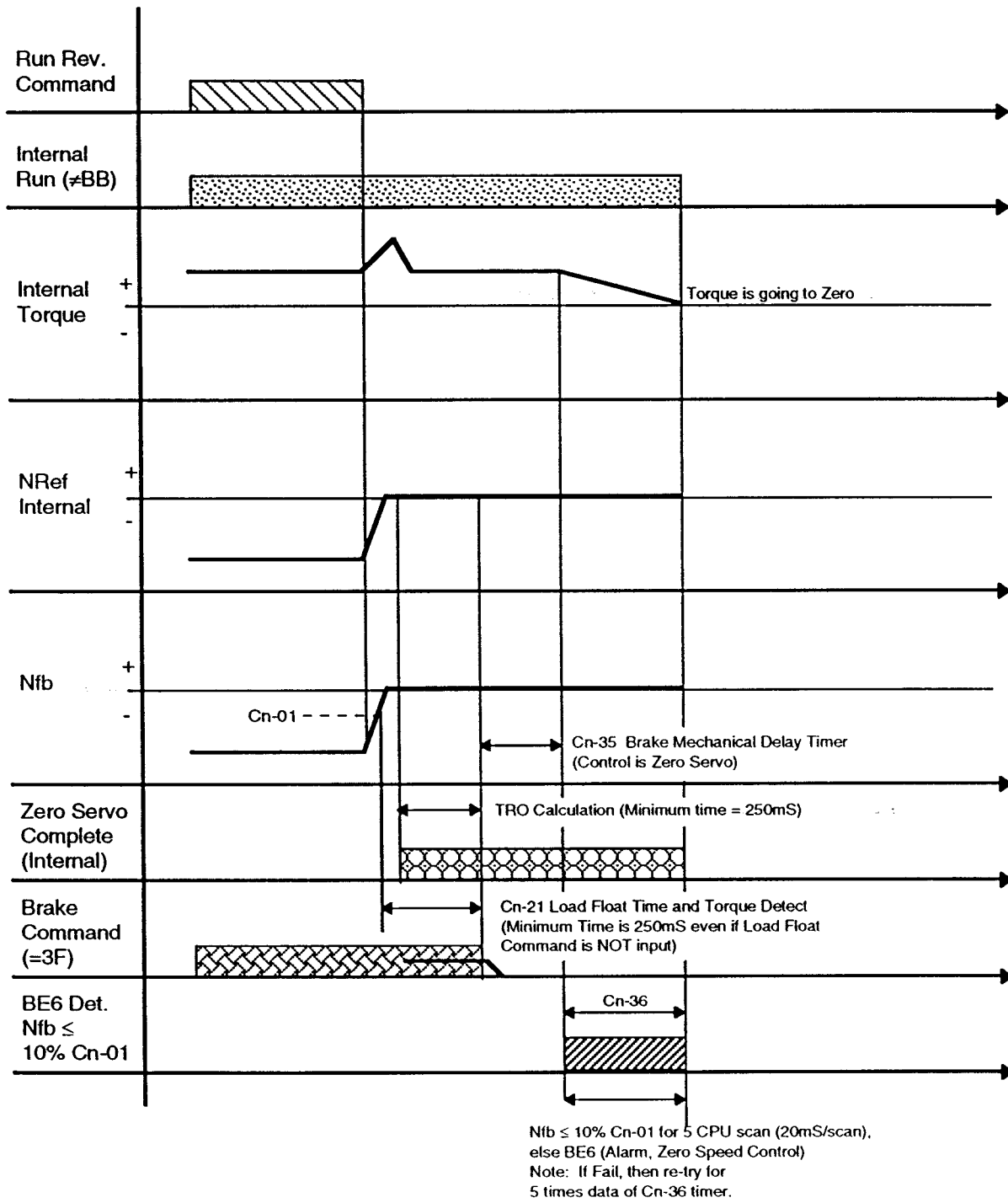

9.3 Micro-Positioning Control

IMPULSE•VG+ offers Micro-Positioning Control for precision in hoisting. This function provides extremely slow speed operation for precise operation, in addition to the normal running speeds programmed by the user. Enabled by an input to the IMPULSE•VG+, this function multiplies the normal speed reference (any of An-01 ~ An-09 or the Analog Reference) by the data of Cn-11. This will prove extremely useful when "spotting" the load. Please refer to the programming method, joystick operation and examples below:

Programming Method:

Constant No.	Range	Initial Data	To Enable Micro-Positioning Control	Remark
Cn-11	0.0 ~ 1.0	0.1	User Choice	Gain of Micro-Positioning Control
Sn-15~Sn-18	00 ~ FF	03	0E	Provides the input to enable Micro-Positioning Control. If Sn-15 ~ Sn-18 are being applied to other functions Micro-Positioning Control can be enabled by the data of Sn-38.
Sn-38	0000~FFFF	711A	711A	Terminal TC5 is pre-programmed for Micro-Positioning Control Input

Joystick Operation:

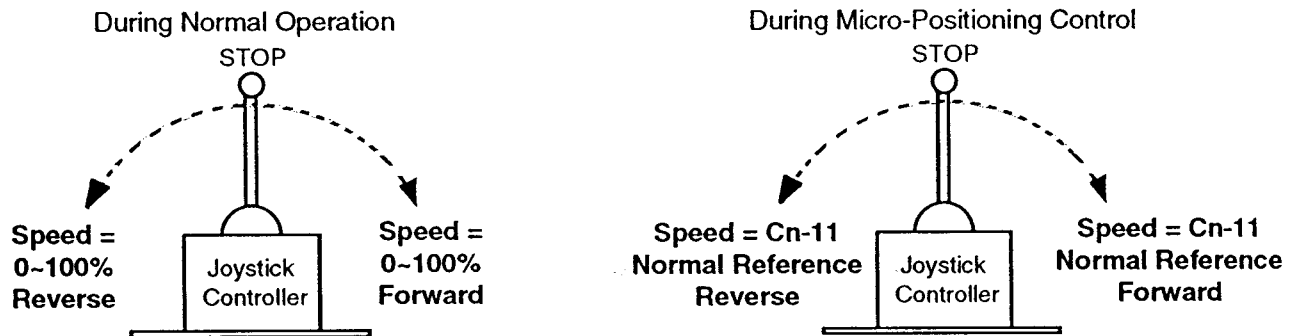

	Cn-11 Data	Speed Reference	Speed During Normal Operation	Speed During Micro-Positioning Control		Cn-11 Data	Speed Reference	Speed During Normal Operation	Speed During Micro-Positioning Control
Example 1	0.1	An-01	10%	1%	Example 2	0.3	An-01	10%	3%
		An-02	25%	2.5%			An-02	25%	7.5%
		An-03	50%	5%			An-03	50%	15%
		An-04	75%	7.5%			An-04	75%	22.5%
		An-05	100%	10%			An-05	100%	30%
		Analog	0 ~ 100%	0 ~ 10%			Analog	0 ~ 100%	0 ~ 30%

9.4 Load Float (Zero Speed)

The IMPULSE•VG+ offers Load Float for precise and responsive handling of loads for hoisting applications. When enabled by the data of Cn-21, this function will hold the load at Zero Position (after Run command is removed) for a duration of time programmed by Cn-21. Note that during the time of Cn-21, the brake will not set, and immediate response to a RUN command (forward or reverse at any speed reference) is available. This function can be combined with Micro-Positioning Control to provide precise positioning of the load. Please refer to the programming method and timing chart below:

Programming Method:

Constant Number	Range	Initial Data	To Enable Load Float	Remark
Cn-21	0 ~ 255 Sec.	10 Sec.	User Choice	Load Float Time is Set
Sn-15~Sn-18	00 ~ FF	03	0F	Provides the input to enable Load Float operation. If Sn-15 ~ Sn-18 are being applied to other functions Load Float can be enabled by the data of Sn-38.
Sn-38	0000~FFFF	711A	711A	Terminal #TC9 is pre-programmed for Load Float Operation Input

Timing Chart for Load Float Function:

(Chart assumes that Load Float input is hardwired (jumper as per Section 3.4.2))

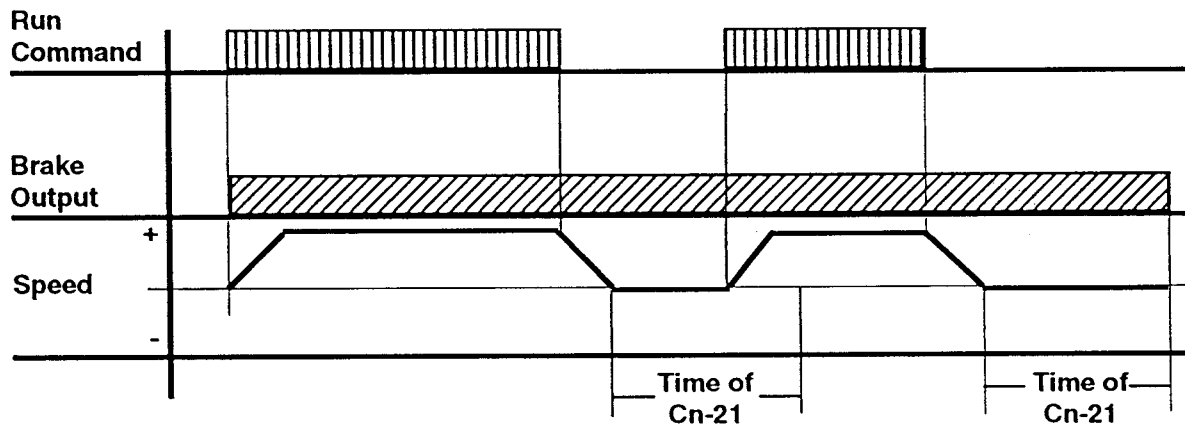

9.5 Quick Stop Function

The IMPULSE•VG+ offers Quick Stop which provides an automatic alternate deceleration time at STOP command. Note that the Quick Stop time differs from the normal deceleration time (changing from a higher speed to a lower speed) and is applied only when the IMPULSE•VG+ receives a STOP command. Please refer to the programming method and timing chart below:

Programming Method:

Constant Number	Range	Initial Data	To Enable Quick Stop	Remark
Sn-05, bit 0	0 or 1	1	1	Data "1" enables the Quick Stop Function
Bn-04	0.5 ~ 3000.0 Seconds	1.0 Second	User Choice < Bn-02	Sets the Quick Stop Deceleration Time (Time from 100% speed to Stop)

Timing Chart for Quick Stop Function:

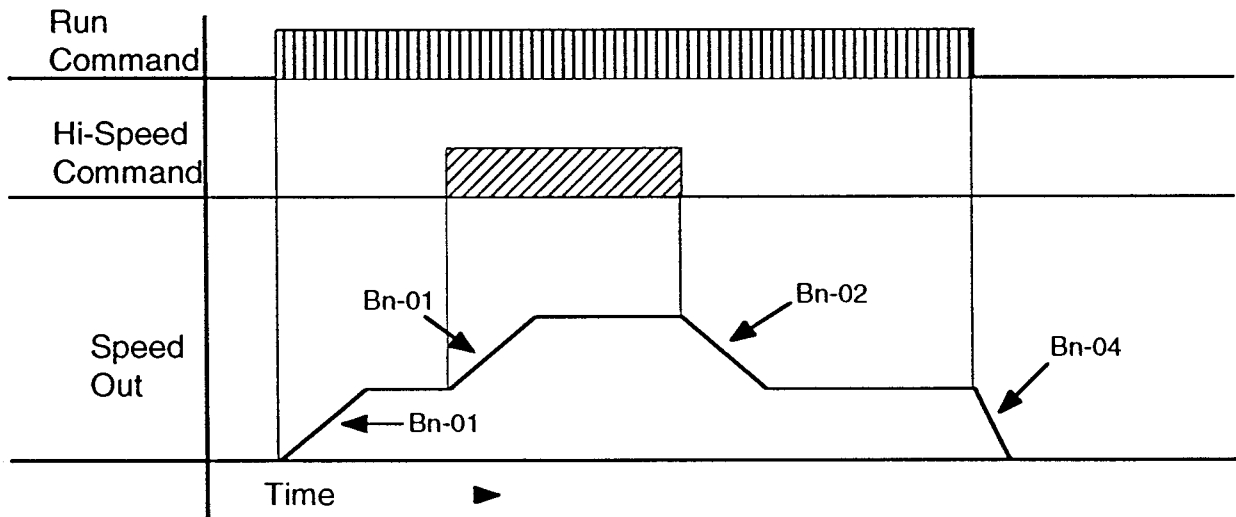

9.6 Reverse Plug Simulation Function

IMPULSE•VG+ offers Reverse Plug Simulation which provides an automatic alternate deceleration time/acceleration time at a change direction command. Note that the deceleration time and acceleration time are set independently of the normal times acceleration and deceleration. Please refer to the programming method and timing chart below:

Programming Method:

Constant	Range	Initial Data	To Enable Reverse Plug Simulation	Remark
Sn-06, bit 0	0 or 1	1	1	Data "1" enables the Reverse Plug Simulation Function
Bn-03	0.5 ~ 3000.0 Seconds	1.0 Second	User Choice	Sets the Reverse Plug Simulation Acceleration Time (Time from Zero Speed to 100% Speed)
Bn-04	0.5 ~ 3000.0 Seconds	1.0 Second	User Choice	Sets the Reverse Plug Simulation Deceleration Time (Time from 100% Speed to Zero Speed)

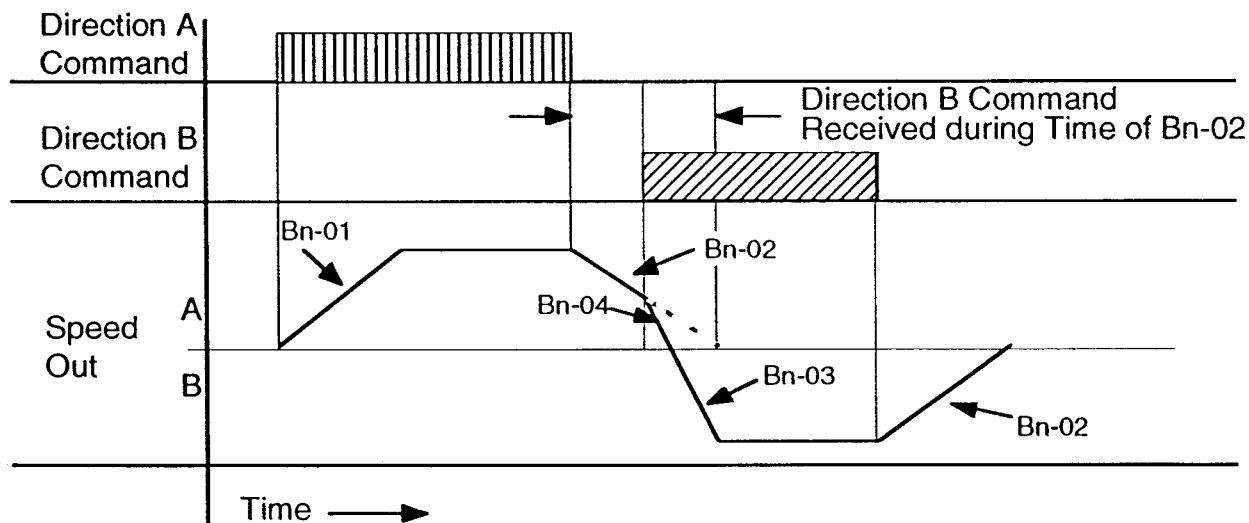

9.7 Automatic Keypad Lockout (Sn-03 functions)

IMPULSE•VG+ provides for programming security and enables an enhanced level of safety with the automatic keypad lockout function. Enabled by the data of Sn-03, this function automatically prohibits unauthorized personnel from making changes to the IMPULSE•VG+ program data. See the programming method below:

Programming Method:

Sn-03	Drive Mode			Program Mode		
	Setting and Reading is Enabled	Only Reading is Enabled	Setting and Reading is Disabled	Setting and Reading is Enabled	Only Reading is Enabled	Setting and Reading is Disabled
0000*	An, Bn	Cn, Dn, Sn, Un	On	An, Bn, Cn, Dn, Sn		On
0101*	An	Bn, Cn, Dn, Sn, Un	On	An, Sn-03	Bn, Cn, Dn, Sn	On
1010*	An, Bn	Cn, Dn, Sn, On, Un		An, Bn, Cn, Dn, Sn, On		
1001^	An, Bn, Cn, Dn, On	Sn, Un		An, Bn, Cn, Dn, Sn, On		
† 0001^		An, Bn, Un	Cn, Dn, Sn, On	Sn-03	An, Bn, Cn, Dn, Sn	On
† 1000^		An, Bn, Un	Cn, Dn, Sn, On	Sn-03	An, Bn, Cn, Dn, Sn	On
0011^	An	Bn, Un	Cn, Dn, Sn, On	An, Sn-03	Bn, Cn, Dn, Sn	On
*Note: Data returns to "0101" at Power Up.						
^Note: Held as is at Power Up						
Remark: Sn-xx, Cn-xx, Dn-xx, On-xx can be directly accessed by depressing the DISPLAY simultaneously with >.						

† Total Lockout Mode

9.8 Ultra-Lift

IMPULSE•VG+ allows the operator to overspeed the motor or hoist when the load is less than 100% of rated capacity. Ultra-Lift determines the value of the load, calculates the maximum safe speed and automatically accelerates to that speed. Please see the programming method below.

Programming Method:

Constant Number	Range	Initial Data	To Enable Ultra-Lift	Remark
Dn-02	Dn-01 ~ 3500 RPM	Dn-01 (1750)	User Choice (≥Dn-01)	The enabler and the maximum speed of the Ultra-Lift Function
Cn-41	0.00 ~ 109.22 (Dn-01 + Dn-02) x 100) *	100.00%	≤ Dn-01	The operating speed at which the Ultra-Lift function calculates the hook load and determines the maximum safe speed (≤Dn-02)
Cn-42	0.00 ~ 30.00 Seconds	2.00 Second	User Choice	The delay time prior to acceleration to Ultra-Lift Speed (time count begins at speed of Cn-41)
Cn-43	0 ~ 100% (of Dn-02)	30%	User Choice (≤30%)	The TRO (calculated torque) derated for Ultra-Lift operation in the lowering direction. When high speed operation is enabled in lowering, please use caution because of the effect of inertia.
Cn-44	0 ~ 100% of Rated Torque	30%	User Choice (≤30%)	The Maximum Speed derated for Ultra-Lift operation in lowering. Maximum speed at lowering = Dn-01 + (Cn-44(Cn-01-Dn-02))

* Round down to the nearest whole number. For example: 55.63 = 55

9.9 Alternate Torque Limit Gain (Cn-29 Function)

IMPULSE•VG+ is normally programmed to disallow the lifting of any load greater than 100% of the hoist rating. However, safety testing is routinely required for all hoisting applications. IMPULSE•VG+ can therefore be programmed to allow for testing of overloads. Since altering the base program could potentially cause some hazard, the alternative torque limit function is provided. The data of Cn-29 "multiplies" the torque limits (Bn-07 ~ Bn-08) to allow overload testing with a simple key switch input. Please see the programming method below.

Programming Method:

Constant No.	Range	Initial Data	To Enable Alternate Torque Limit	Remark
Cn-29	0.0 ~ 2.0	1.0	1.2	When activated by one of the digital inputs (see below), the Data of Bn-07 ~ Bn-09 is changed proportionally by the gain of Cn-29
Sn-15 ~ Sn-18	00 ~ FF	00 ~ 03	13	One of the VGIF input terminals can be programmed for "Alternate Torque Limit" input by data "13". Note that a Key-Switch should be used for changing the torque limits.
Sn-38	0000 ~ FFFF	711A	719A	If the inputs of the VGIF are occupied by other functions, the VGIN input card can be applied. With data "719A", VGIN terminal # TC8 enables the "Alternate Torque Limit" function. Note that a Key-Switch should be used for changing the torque limits.

9.10 Slack Cable Detection

IMPULSE•VG+ offers Slack Cable Detection for application to bucket hoists. When the bucket of the hoist lowers to engage the material, the output torque of the drive dips below a set-point. If output torque falls below this set-point, a PHC or relay is output. This signal is then used by a higher intelligence controller to engage indicator lights or other devices. Please see below for programming details:

Programming Method:

Constant Number	Range	Initial Data	To Enable Slack Cable Detection	Remark
Cn-34	0.00 ~ 300.00 % Rated Torque	100.00	≤30.00%	When Output Torque-(as indicated by Un-26) falls below the level of Cn-34, an output is generated.
Bn-21	0.00 ~ 2.55 Sec	0.00	0.50 Sec	Used to avoid false indications when near zero speed during reverse plugging.
Sn-20 ~ Sn-24	00 ~ FF	Sn-20 = 3F Sn-21 = 47 Sn-22 = 60 Sn-23 = BD Sn-24 = 3F	36	One of the VGOUT output SSRs terminals can be programmed for "Slack Cable Detection" output by data "36".

9.11 Speed Feedback (Nfb) Nfb is Positive/Nfb is Negative

Certain applications use linear encoders which do not incorporate a quadrature signal. To maintain knowledge about the position of the machine, the encoder pulses are accumulated. Since quadrature is not available, the IMPULSE•VG+ outputs a signal that identifies the direction of travel. (This output signal is unrelated to the Run command.) Please see the programming details and timing chart below:

Programming Method:

Constant Number	Range	Initial Data	To Enable Nfb is Positive	Remark
Sn-20 ~ Sn-24	00 ~ FF	Sn-20 = 3F Sn-21 = 47 Sn-22 = 60 Sn-23 = BD Sn-24 = 3F	12	When Nfb is Positive (Forward Running) the PHC/ relay is output

Constant Number	Range	Initial Data	To Enable Nfb is Positive	Remark
Sn-20 ~ Sn-24	00 ~ FF	Sn-20 = 3F Sn-21 = 47 Sn-22 = 60 Sn-23 = BD Sn-24 = 3F	13	When Nfb is Negative (Reverse Running) the PHC/ relay is output

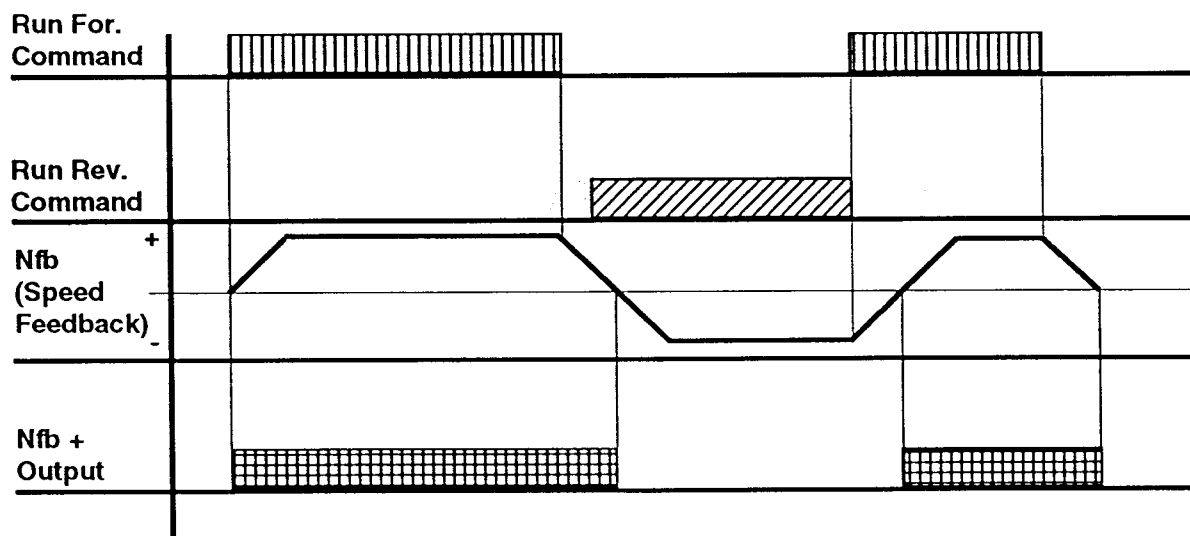

9.12 Upper and Lower Limit Functions

Circumstances can arise where the brake is not fully operational and the standard starting sequence can cause an unsafe tensioning of the hoisting cable. Therefore, it is MANDATORY that the user apply the upper limit function either by using a geared limit switch or another method. IMPULSE•VG+ offers two types of upper limit inputs and two types of lower limit inputs. Please see the programming methods below.

Programming Method:

Constant Number	Range	Initial Data	To Enable Upper Limit 1 (Slow Down)	Remark
Sn-15~Sn-18	00 ~ FF	03	0A	Provides the Input to Enable Upper Limit 1 Sequence. If Sn-15 ~ Sn-18 are being applied to other functions, Upper Limit 1 can be enabled by the data of Sn-38.
Sn-38	0000~FFFF	711A	7111	Terminal #TC1 is pre-programmed for Upper Limit 1 Operation Input
Note: Upper Limit 1 Sequence: At Upper Limit 1 input, the IMPULSE•VG+ slows down to the speed of An-01 (by decel time Bn-02). Continued operation in the UP direction is prohibited. For N/C contact				

Constant Number	Range	Initial Data	To Enable Upper Limit 2 (Stop)	Remark
Sn-15~Sn-18	00 ~ FF	03	0B	Provides the Input to Enable Upper Limit 2 Sequence. If Sn-15 ~ Sn-18 are being applied to other functions, Upper Limit 2 can be enabled by the data of Sn-38.
Sn-38	0000~FFFF	711A	7112	Terminal #TC2 is pre-programmed for Upper Limit Operation Input
Note: Upper Limit 2 Sequence: At Upper Limit 2 input, the IMPULSE•VG+ stops (by decel time Bn-02). Continued operation in the UP direction is prohibited. For N/C contact.				

9.12 Upper and Lower Limit Functions (Continued)

Constant Number	Range	Initial Data	To Enable Lower Limit 1 (Slow Down)	Remark
Sn-15~Sn-18	00 ~ FF	03	0A	Provides the input to enable lower limit 1 sequence. If Sn-15 ~ Sn-18 are being applied to other functions, lower limit can be enabled by the data of Sn-38.
Sn-38	0000~FFFF	711A	7114	Terminal #TC3 is pre-programmed for lower limit 1 operation input
Note: Lower Limit 1 Sequence: At lower limit 1 input, IMPULSE•VG+ slows down to the speed of An-01 (by decel time Bn-02). Continued operation in the DOWN direction is prohibited. for N/C contact				

Constant Number	Range	Initial Data	To Enable Lower Limit 2 (Stop)	Remark
Sn-15~Sn-18	00 ~ FF	03	0D	Provides the input to enable lower limit 2 sequence. If Sn-15 ~ Sn-18 are being applied to other functions, upper limit 2 can be enabled by the data of Sn-38.
Sn-38	0000~FFFF	711A	711A	Terminal #TC4 is pre-programmed for lower limit operation input
Note: Lower limit 2 sequence: At lower limit 2 input, IMPULSE•VG+ stops (by decel time Bn-02). Continued operation in the DOWN direction is prohibited. For N/C contact.				

9.13 Torque Limit Acceleration/Deceleration Function

Because IMPULSE•VG+ is a flux vector drive, it can dynamically control the torque output of the motor at all times. During normal acceleration and deceleration, the lower limit of actual torque depends on the programmed acceleration and deceleration times. The torque output is equal to that required to accelerate or decelerate the load in the programmed time. Note that under absolute full-load conditions, the output torque during accelerate and decelerate may already be at the limits set by Bn-07 ~ Bn-09.

Certain demanding applications require that the acceleration and deceleration times be as short as possible at all load conditions, without creating hazardous conditions to either the equipment or personnel. For these applications, Electromotive Systems offers the torque limit acceleration/ deceleration function. When enabled, acceleration and deceleration programmed times (Bn-01 ~ Bn-04) become second priority. The output torque during accelerate and decelerate are fixed at the limits set by Bn-07 ~ Bn-09 and the shortest possible accelerate/decelerate times are achieved. Please see the programming method below:

Programming Method:

Constant No.	Range	Initial Data	To Enable Torque Limit Accel/Decel	Comments
Sn-15-Sn-18	00 ~ FF	03	12	Provides the input to enable torque limit accel/decel sequence. If Sn-15 ~ Sn-18 are being applied to other functions, torque limit accel/decel can be enabled by the data of Sn-38.
Sn-38	0000-FFFF	711A	711A	Terminal #TC7 is pre-programmed for torque limit operation input

Section 10: Troubleshooting

Warning!

- Do not touch any circuit components while the main, AC power is on. In addition, you must wait until the red "CHARGE" lamp (located just left of the terminal strip) is extinguished before performing any service on the unit. It may take as long as 10 minutes for the charge on the main DC bus capacitors to drop to a safe level. Failure to adhere to this warning could result in personnel injury.
- Do not check signals during operation.
- Be sure to ground the IMPULSE•VG+ using the G (E) terminal.
- Never connect the main circuit output terminals (T1, T2, T3) to the main, three-phase input power supply.

10.1 Periodic Inspection

The IMPULSE•VG+ inverter is virtually maintenance free. Only a few simple items should be periodically checked and these are summarized below:

Component	Check	Corrective Action
External terminals, mounting bolts, connectors, etc.	Loosened screws or connections	Tighten
Cooling Fins	Build-up of dust or dirt	Blow with compressed air (from approx. 57 to 85 PSI)
Printed Circuit Board	Accumulation of oil, mist or dirt	Clean the board. If grime cannot be removed consider replacement
Cooling Fan	Abnormal noise or vibration	Replace. If total operation exceeds 20,000 hours, also consider replacement
Power Elements	Accumulation of dust or dirt	Blow with compressed air (from approx. 57 to 85 PSI)
DC bus capacitor	Discoloration or odor	Replace all of the capacitors

10.2 Troubleshooting

This section is presented as a series of simple instructions/suggestions for troubleshooting using the standard keypad and an analog VOM (Simpson 260 or equivalent). It has been divided into four sections according to the nature of the problem.

- 10.2.1: Motor/Drive Won't Run
- 10.2.2: Motor Won't Accelerate Smoothly
- 10.2.3: Motor Appears Unstable (Vibration or Hunting)
- 10.2.4: Fault Trip

Please refer directly to the appropriate section.

10.2.1 Motor/Drive Won't Run

Possible Problem	Item to Check	Comments
No input voltage	Measure the three-phase, AC input voltage directly on the inverter terminals L1, L2, L3.	Voltage should be within tolerances given below and should be balanced within 2%. • 230 Volt units: 180-253 VAC • 460 Volt units: 342-506 VAC
Keypad is not illuminated	Check glass 1A fuses on small card. Make sure voltage selector jumper is in correct position (refer to Sec. 3.1.5).	Replace fuses or move jumper to correct location .
Charge lamp is not illuminated	Make sure the incoming power has been removed before performing this check Use an analog VOM (Simpson 260 or equal) and measure the resistance from output terminal T1 (positive lead) to main circuit terminal BO/P.	Resistance should measure 100 Ω or less. If you detect an open circuit the pre-charge resistor is opened. A damaged pre-charge resistor is typically caused by a shortage braking transistor (see Sec. 10.3).
No run command at terminal strip	Make sure the inverter is programmed for terminal strip control (Sn-04=xx0x, remote seq LED should be lit). Use the monitor parameter Un-07 (see Sec. 6.8 for details) to make sure you are getting the correct inputs to the inverter's control terminal strip.	2 wire control: you should get an input on terminal 1 (forward run) or terminal 2 (reverse run). 3 wire control: you should have a maintained input to terminal 2 (for stop input) and a momentary start input at terminal 1.
No run command at keypad	Make sure the inverter is programmed for keypad control of run/stop (Sn-04=xx1x, remote seq LED on keypad is not lit).	Set Sn-04=xx1x If the inverter operates from the terminal strip, replace keypad.
Keypad is blinking "bb"	Inverter is receiving an external immediate stop ("bb") command at the terminal strip. Check the programming/wiring of the multi-function input terminals.	Correct external wiring to VGIF terminals 5, 6, 7, or 8 (depending on which is programmed for "bb" command).
No speed reference command	Use the keypad display with the N prefix to observe the level of the enabled reference. Terminal control is denoted by the illumination of the remote reference LED on the keypad.	Keypad control: make sure the speed reference command is present. Terminal control: make sure the speed pot is wired correctly to terminals 15, 13, 17, or make sure the remote current reference is wired correctly to terminals 14 (+) and 17.
Output voltage balanced?	Use an analog voltmeter to measure the three-phase output voltage across terminals T1, T2, T3.	Voltages should be balanced within 3%. If you use a digital meter the readings will be distorted due to the shape of the output waveform.
Tripping circuit breaker or blowing input fuses?	Input rectifier bridge damaged.	See Section 10.3 for test method.

10.2.2 Motor Stalls or Won't Accelerate Properly

Possible Problem	Item to Check	Comments
Load inertia too large	Extend the programmed acceleration time.	If extending the time doesn't improve the situation, uncouple the load from the motor and try again.
Motor connected improperly	Open the motor conduit box and confirm the motor leads are connected for the proper voltage.	Also make sure the motor doesn't have an opened phase.
Encoder connected improperly	Check the data of Cn-09. Make sure the encoder is connected as described in Section 3.	Refer to Section 3.3.2 and Section 6.4.1 for details.
Torque Limit Load Check is working?	Use the keypad display (Un-36) to measure the motor's torque output during acceleration.	The output torque cannot exceed 120% of the motor's rated torque due to the setting of Bn-07 and Bn-08. Changing the torque limit values should be carefully considered and discussed with Electromotive Systems.
Low impedance motor (Wound rotor)?	Is the motor a wound rotor type?	Consider using an output reactor between the IMPULSE•VG+ and the motor. Consider installing some level of resistance in the secondary circuit.
Inverter is too small for load	Make sure the motor's rated current is less than (or equal to) the inverter's rated current.	Inverter's rated current is on the nameplate of the unit and also published in Section 3 of this manual.
Frequency reference drifting (not stable)	Use the keypad to monitor the frequency reference (Un-01).	Stabilize source or extended accel and decel times (Bn-01, Bn-02, Bn-03, Bn-04)

10.2.3 Motor Hunting or Vibration (Instability)

Problem/Symptom	Item to check	Comments
The Digital Operator indicates negative direction when Forward command is provided.	Observe the digital operator for negative (-) sign during Forward Run.	See Section 7.4.1. Connect the encoder properly Perform autotune function using VectorMate.
Motor isn't running at torque limit.	Check the data of Un-26.	If the data of Un-26 exceeds the data of any of Bn-07 ~ Bn-09, the load may be excessive or the motor/IMPULSE•VG+ may be undersized. Also check the function of the brake to be sure that it is releasing appropriately.
Speed reference drifting (not stable)	Use the keypad to monitor the Speed reference (Un-01)	Stabilize source or extend accel and decel times (Bn-01, Bn-02, Bn-03, Bn-04).
Vibration or Hunting	Check the Encoder	Problem could be related to the Encoder connection/clarity of the recieved signal. See Section 10.4 for details.

10.2.4 Fault Trip Condition

After experiencing a fault trip condition, remove the main AC power supplying the inverter. The fault code(s) will be stored in memory. When you reapply power, the keypad will blink the alpha-numeric code corresponding to the original fault trip for two seconds, then will return to the previous display mode. If you want to observe the trip condition more closely, simply depress the DISPLAY key until the fault trip display is accessed. This mode will carry a prefix of "U1" to indicate the first fault, "U2" to indicate the second fault, etc. A maximum of 4 sequential faults can be stored in memory and you can access them by pressing the \wedge key until you observe all the faults. (You can scroll through all registered faults, up to and including the fourth).

The table given below lists all potential fault conditions, their likely causes and any necessary corrective measures.

Fault Display	Status	Possible Cause	Recommended Action
UV1 Undervoltage (PUV)	Undervoltage status occurs for more than 2 seconds during running.	Input voltage drops below 210V or less for 230V class (420V or less for 460V class).	Check the wiring of the power source side equipment. Correct the line voltage. Check branch fuses.
UV2 Undervoltage (CUV)	Control circuit voltage becomes low during operation.	Control board voltage is removed.	
UV3 Undervoltage (MC-ANS fault)	Main circuit MC contactor does not operate properly.	MC contactor is open.	
UV blinks Undervoltage detection	Undervoltage status occurs for more than 2 seconds during stop.	Input voltage drops below 210V or less for 230V class (420V or less for 460V class).	Transistor error may occur. Investigate the error cause, correct it, then restart.
OC Overcurrent	Inverter output current exceeds 120% of transistor rated current. Output shuts off.	Inverter output side short-circuit; excessive load inertia (J); excessively short setting of accel/decel time; special motor use; motor start during coasting; start of motor with larger capacity than inverter; inverter output side magnetic contactor ON/OFF.	
OV Overvoltage	Main circuit DC voltage exceeds 410V or more for 230V class (820V or more for 460V class) because of excessive regenerative energy from the motor. (Exceeds overvoltage protection level.) Output shuts off.	Decel time setting is not sufficient; minus load (cranes, etc.) is decreasing; high input voltage compared to motor rated voltage.	If braking torque is not proper, extend the decel time; check that the load is not minus; check the power supply voltage. Check braking resistors and/or brake unit.
OV blinks Overvoltage during stop	Main circuit DC voltage rises above the detection level while the inverter output is off. Detection level: 410V or more for 230V (820V or more for 460V).	Check the power supply voltage.	Check the power supply voltage.
FU Fuse blown	DC bus fuse blown.	Check for damaged transistor, load short, circuit grounding, etc. Do not change fuse.	Check for damaged transistor, load side short circuit, grounding, etc. Do not change fuse.

10.2.4 Fault Trip Condition (Continued)

Fault Display	Status	Possible Cause	Recommended Action
OH1 Motor overheat	Motor is overheated.	The motor temperature exceeds the value of Dn-18.	Check motor cooling fan and motor overload.
OH2 Cooling fin overheat	Temperature rise caused by inverter overload operation or intake air temperature rise. The inverter output is shut off when the cooling fin overheat is detected by thermistor.	Load is too large; setting time is too short; intake air temperature exceeds 113 °F (45 °C).	Correct load size, or intake air temperature.
OL1 Motor overload	The inverter output is stopped when output current to the motor is detected by the electronic thermal in the inverter.	Overload, long operation at low speed; motor rated current setting is wrong.	Investigate the cause of overload and review the operation pattern, and motor/inverter capacities. (If inverter is repeatedly reset after an overload occurs, the inverter may fault. Investigate and correct the cause of an overload before restart.) Set the rated current of motor nameplate value.
OL2 Inverter overload	Inverter overload protection operates because of electronic thermal overload.		Correct load size, operation pattern or recheck the inverter capacity.
THM Thermistor line break	Thermistor is not connected, or thermistor connection is faulty (see On-02, bit 2).	Thermistor burned open; On-02 is set for a thermistor that the unit does not have.	Replace thermistor; change On-02.
RR Braking transistor fault	Braking transistor failed.	Braking transistor output shorted.	Check brake resistor wiring.

10.2.4 Fault Trip Condition (Continued)

Fault Display	Status	Possible Cause	Recommended Action
FAN Cooling fan failure	The cooling fan stopped while power is on.	Debris lodged in fan.	Remove debris; check fan wiring; replace fan.
EF1 External fault is input	External fault input causes stop (BB).	External fault condition occurred.	Check the external circuitry (sequence).
EF1 blinks External fault is input	External fault is input, but operation continues.		
EF5, 6, 7 or 8 blinks Terminal external fault input	Terminal 5, 6, 7, or 8 external fault is set to continuous operation.		
SE2	Torque Proving Sequence Only! IFB OK = 0 after 1 Sec. Output current feedback is NOT OK after start.	Torque hasn't reached value of Cn-38 within 1 sec.	Call Electromotive Systems.
SE3 Brake Answer Lost	Torque Proving Sequence Only! Brake hasn't been released.	Brake answer is NOT received within the time of Cn-39 after brake release command is provided.	
SE4 Brake Answer Lost	Torque Proving Sequence Only! Brake answer is lost during operation.	Brake has closed during operation.	
SE6 Brake Condition at Stop Test is Failed	Torque Proving Sequence Only! Brake test at stop is NOT good.	Brake has failed or loosened.	
OP Digital Monitor Unit fault	Digital monitor has failed.	The operator is mounted when under the program mode or during operation by the operator.	Remove power and remount operator.
OP3 Incongruent Option Card Connection	Option card has failed.	Unmatching option card attached to the drive.	Replace option card.

10.2.4 Fault Trip Condition (Continued)

Fault Display	Status	Possible Cause	Recommended Action
BE1 Brake Condition at Start Test is Failed	Brake Proving Sequence Only! Break condition at start is NOT good.	Brake is too loose or has failed.	Call Electromotive Systems.
BE2	Brake Proving Sequence Only! IFB OK = 0 after 1 Sec. Output current feedback is NOT OK after start.	Torque hasn't reached value of Cn-38 within 1 sec.	
BE3	Brake Proving Sequence Only! NFB = 0 after brake release command is output.	Brake probably not released.	
BE6 Brake Condition at Stop Test is Failed	Brake Proving Sequence Only! Brake test at stop is NOT good.	Brake has failed or loosened.	
OS Overspeed is Detected	Dangerous Condition! Actual motor speed exceeds the value set by Cn-16.	Drive may be overloaded.	Check load, and check for noise on encoder leads.
PGO PG Feedback = 0	Encoder feedback is zero.	Encoder wiring may be faulty, brake hasn't released.	Check encoder wiring and brake. Replace encoder.
DEV Deviation fault	Dangerous Condition! Actual motor speed is incongruent with internal speed reference beyond regulation level (Cn-04).	Encoder failed, noise on encoder feedback.	Check encoder grounding, increase Cn-04 < 30%, replace encoder.
LF Open Phase fault	Output phase is disconnected.	Open motor lead; bad motor.	Check wiring; replace motor.
UL1 Upper Limit 1 Function is Input	The upper limit (slow down) switch status is changed.	Upper limit (slowdown) is tripped.	Check limit.
UL2 Upper Limit 2 Function is Input	The upper limit (E-Stop) switch status is changed.	Upper limit (stop is tripped)	Check limit.

10.2.4 Fault Trip Condition (Continued)

Fault Display	Status	Possible Cause	Recommended Action
LL	Line Loss fault (L1 or L2)	Input is lost at L1 or L2	Check the wiring of the power source.
LL1 Lower Limit 1 Function is Input	The lower limit (slow down) switch status is changed.	Lower limit (slowdown) is tripped.	Check limit.
LL2 Lower Limit 2 Function is Input	The lower limit (E-Stop) switch status is changed.	Lower limit (stop) is tripped.	Check limit.
CPF00 Transmission error or control function hardware fault (including RAM and PROM)	Digital operator transmission fault at startup.	External noise; excess vibration or shock; the inverter output is shut-off when a transmission error occurs in the control circuit or a component fails.	Record all data, and then make initialization. Turn off the power supply once, and then turn it on again. If the fault still exists, call Electromotive Systems.
CPF01 Transmission error	Digital operator transmission fault during running.		
CPF02 BB circuit fault	Base block circuit error.		
CPF03 NV-RAM (S-RAM) fault	Non-volatile RAM fault.		
CPF04 NV-RAM (BCC, access code fault)	Constant destroyed; constant initialization fault.		
CPF05 A/D converter fault in CPU	Analog to digital converter chip fault.		
CPF06 Option connection fault	Option card disconnection.		
CPF010 DSP Hardware Fault	VGIN10 Board Fault		
CPF20 AI Option A/D converter fault	Analog speed reference error.		

10.2.4 Fault Trip Condition (Continued)

Fault Display	Status	Possible Cause	Recommended Action
OPE01 KVA constant setting range fault	Sn-01 not set correctly.	Sn-01 not set correctly.	See p.43 for proper setting.
OPE02 Constant set value fault	An-XX, Bn-XX, Cn-XX, On-XX setting range fault.	Constants scrambled.	Check constants against initialized values.
OPE03 Constant set value fault	Sn-15 ~ Sn-18 (multifunction input) setting range fault.	Constant set incorrectly.	See p.48-49 for proper setting.

10.3 Corrective Action at Specific Faults

Fault Code	Meaning	What To Do
SE2	IF BOK = 0 after 1 Second. IMPULSE•VG+ checks for current flow (Ifb) at start. If no current is flowing at start, SE2 is displayed.	<p>Increase automatic speed regulator (ASR) gain at low speed.</p> <ol style="list-style-type: none"> 1. Set Cn-22 to data of $\approx 10\text{--}30$ above data of Bn-05 2. Set Cn-23 to data of Bn-11
BE1	Brake condition at start is insufficient to hold zero speed (Nfb > 10% Cn-01)	<ol style="list-style-type: none"> 1. Check for movement through brake. If brake is worn, repair or replace. 2. Be sure that 50% of Bn-11 > 10% of Cn-01 3. Check encoder signal for noise, and, if possible, eliminate the noise. Be sure that encoder shield is connected to terminal 12 of the IMPULSE•VG+ logic card. If the noise source is impossible to eliminate, increase the data of Cn-01 to no more than 10%. 4. Decrease the data of Cn-37 (data must always be $\geq 100\text{mSec!}$)
BE2	IF BOK = 0 after 1 second. IMPULSE•VG+ checks for current flow (Ifb) at start. If no current is flowing at start, BE2 is displayed.	<ol style="list-style-type: none"> 1. Increase the data of Bn-11 to no more than 3% 2. Increase ASR gain at low speed. 2a. Set Cn-22 to data of $\approx 10\text{--}30$ above data of Bn-05 2b. Set Cn-23 to data of Bn-11
BE3	Nfb = 0 after brake release command is Issued by IMPULSE•VG+	<ol style="list-style-type: none"> 1. Check to see if the brake is slow in releasing (mechanical lag time is too long). Be sure that the brake is mechanically OK. 2. Increase the data of Cn-35 (brake mechanical lag time) to equal the actual lag time (≤ 2.0 seconds). 3. Be sure that the data of An-01 > 0.00
BE6	Brake test at stop is not good. Nfb > 10% Cn-01	<ol style="list-style-type: none"> 1. Make sure that the brake can sustain a minimum of 140–150% motor torque. 2. Check to see if the brake is slow in closing (mechanical lag time is too long). Be sure that the brake is mechanically OK. 3. Increase the data of Cn-35 (brake mechanical lag time) to equal the actual lag time (≤ 2.0 seconds). 4. Check encoder signal for noise, and, if possible, eliminate the noise. Be sure that encoder shield is connected to terminal 12 of the IMPULSE•VG+ logic card. If the noise source is impossible to eliminate, increase the data of Cn-01 to no more than 10%. 5. Increase the data of Cn-36 in increments of 0.1 Second (1.0 second maximum)

10.3 Corrective Action at Specific Faults (Continued)

Fault Code	Meaning	What To Do
Os	Overspeed is Detected (Nfb ≥ Cn-16) Actual speed ≥ Cn-16(Dn-02)	<ol style="list-style-type: none"> 1. Check encoder signal for noise, and, if possible, eliminate the noise. Be sure that encoder shield is connected to terminal 12 of the IMPULSE•VG+ logic card. 2. Increase data of Cn-16 to no more than 120%. 3. Drive has insufficient torque for the load. Increase Bn-09 to 150% maximum. 4. Encoder has failed. Repair or replace.
PGo	PG Feedback = 0 IMPULSE•VG+ does not see any encoder signal.	<ol style="list-style-type: none"> 1. Check for open circuits in encoder cable (connections and cables) 2. Swap A+ and A- on PG-T card 3. Drive has insufficient torque for the load. Increase Bn-07 to 150% maximum. (Observe by Un-26) 4. Encoder has failed. Repair or replace.
dEv	Deviation Fault Motor speed is out of range of drive speed.	<ol style="list-style-type: none"> 1. Check encoder signal for noise, and, if possible, eliminate the noise. Be sure that encoder shield is connected to terminal 12 of the IMPULSE•VG+ logic card. 2. Swap A+ and A- on PG-T card. 3. Drive has insufficient torque for the load. Increase Bn-07 to 150% maximum. (Observe by Un-26). 4. Increase data of Cn-04 to no more than 20%. 5. Encoder has failed. Repair or replace.

10.4 Corrective Action for Miscellaneous Problems

Problem	What To Do
Alarm sounds but no fault is displayed on the digital operator	<ol style="list-style-type: none"> 1. Make sure that the output of the VGOUT card or MF01 card is loaded properly (i.e. contactor or inductive load ≤ 1 amp) 2. Be sure that there are surge suppressors or dropping resistors on the VGOUT load. 3. Install 0.1μF capacitor (Part #005-8032) between output and X1.
Movement up before going down	<ol style="list-style-type: none"> 1. Check encoder signal for noise, and, if possible, eliminate the noise. Be sure that encoder shield is connected to terminal 12 of the IMPULSE•VG+ logic card. 2. Increase the data of Cn-35 to the actual amount it takes for the brake to Open.
It takes too long to Brake Prove at Stop or Start	<ol style="list-style-type: none"> 1. Increase ASR gain at low speed. <ol style="list-style-type: none"> 1a. Set Cn-22 to data of $\approx 10\sim 30$ above data of Bn-05 1b. Set Cn-23 to data of Bn-11 2. Increase the data of Cn-24 to NO MORE than 20.
Drive doesn't detect Brake failure at start	<ol style="list-style-type: none"> 1. Increase the data of Cn-38 to 100% 2. Decrease the data of Cn-01 so that 50% of Bn-11 > 10% of Cn-01
Drive doesn't detect Brake failure at stop	<ol style="list-style-type: none"> 1. Decrease the data of Cn-36 2. Decrease the data of Cn-01 so that 50% of Bn-11 > 10% of Cn-01
Drive current is higher than expected	<ol style="list-style-type: none"> 1. Check encoder signal for noise, and, if possible, eliminate the noise. Be sure that encoder shield is connected to terminal 12 of the IMPULSE•VG+ logic card. 2. Be sure that the proper encoder is being applied. 3. Increase Dn-06 in increments of 0.1 until current reaches acceptable levels.

10.5 Power Section Check

Warning!

- Do NOT touch any circuit components while AC main power is on or immediately after the main AC power is disconnected from the unit. You must first wait until the red "CHARGE" lamp (always located just left of the main power terminal strip) is extinguished. It may take as long as 10 minutes for the charge on the main DC bus capacitors to drop to a safe level. Failure to adhere to this warning could result in serious injury.

THESE ARE ALL POWER OFF CHECKS !

It is very easy to check the entire power section of the inverter. It should take less than 5 minutes and you can use a simple, analog (not digital) VOM (Simpson 260 or equivalent). Just follow the procedure outlined in the table on the facing page.

10.5 Power Section Check (Continued)

Device	VOM (on R X 1 Scale)		Normal Reading	Abnormal Reading
	Positive Lead	Negative Lead		
Input Rectifier Bridge	L1	+	7-100 Ω	0 or infinite Ω
	L2	+		
	L3	+		
	-	L1		
	-	L2		
	-	L3		
	L1	-	Infinite Ω	Less than infinity
	L2	-		
	L3	-		
	+	L1		
	+	L2		
	+	L3		
Bus Capacitors	+	-	Observe gradually increasing resistance	0 Ω
Pre-charge Resistor	T1, T2, T3	+	100 Ω or less	Infinite Ω
Output Transistors *1 *2	T1	+	7-100 Ω	0 or infinite Ω
	T2	+		
	T3	+		
	-	T1		
	-	T2		
	-	T3		
	T1	-	Infinite Ω	Near 0 Ω
	T2	-		
	T3	-		
	+	T1		
	+	T2		
	+	T3		
Braking Transistor	-	B2	7-100 Ω	Near 0 Ω
	B2	-	Infinite Ω	

*1 If the bus fuse is blown you must install a jumper across the fuse terminals to get accurate resistance measurements.

*2 If the pre-charge resistor is open, you will read infinite Ω between + and any output terminal unless you install a temporary jumper across the resistor.

- 1) Use surge absorbers (R-C networks) on all relay and contactor coils.
- 2) Shielded cable shall be used for all low level D.C. speed reference signals (0-10VDC, 4-20 mA). Shield should be grounded only at the AF drive side.
- 3) Use a minimum of #16 AWG for control wiring, and #12 AWG (or larger) for power wiring. Size according to N.E.C. table 310-16.
- 4) The following is required for all dual motor bridge cranes and suggested for center driven cranes, trolleys and hoists. Upsize the wiring one size for every 25 feet of distance between AF drive and motor to account for voltage drop (which becomes significant at low frequencies).
- 5) Use time delay fuses for AF drive input protection. They shall be sized at approximately 150% of AF drive continuous rated amperage.
- 6) Control and power wiring (including dynamic braking resistor wiring) shall be kept separate on terminal block strip.
- 7) Keep control (directional and speed command inputs to the AF drive) and power wiring from running together in parallel paths on the panel or in conduit runs. Keep control and power festoon wiring in different cables and separated.
- 8) If control and power wiring do meet on a panel, cross them perpendicularly.
- 9) Before applying power to the AF drive, check the output circuit (T1, T2, T3) for possible short circuits or ground faults.
- 10) Always mount the AF drive in its proper (vertical) orientation with at least 3" of clearance on all four sides. AF drives should be housed in appropriate NEMA rated enclosures for the environment in which they will be used.
- 11) Keep AF drive heatsink clear of any obstructions (components on panel) to ensure proper cooling air flow.
- 12) If using externally mounted interface boards, or remotely mounted speed reference signals, use shielded cable from the interface output or remote speed reference to the AF drive control input terminals.
- 13) On external input devices (control), hard contact inputs are preferred rather than solid state inputs into the control voltage input boards (TC-GIF__, TC-SIF__, TC-SLC__).
- 14) If the input device is a PLC triac output, a 5K ohm, 10 watt resistor may have to be used between the signal and L2 (X2).
- 15) AF drives should always have the cover mounted on unit during normal operating conditions to protect the digital operator (Specific to Electromotive Systems IMPULSE•G Series, IMPULSE•VG Series and IMPULSE•P series).

- 16) All ground terminals or screws ("G" or "E") must be grounded back to earth ground.
 - 17) If the power source is greater than 500 KVA, there should be at least 3% impedance in the line between the source and the input to the AF drive.
 - 18) Incoming power supply voltage must be limited to 230 volts \pm 10% or 460 volts \pm 10%.
 - 19) On existing wound rotor motor applications >25HP, a line reactor of 3% impedance shall be required on the load side of the AF drive. (Specific to Electromotive Systems IMPULSE•G Series, IMPULSE•VG Series, and IMPULSE•P series).
 - 20) When using more than one transformer for control power, properly phase each transformer with respect to other(s).
 - 21) All line and ground wiring should be disconnected when any welding is being done on or to the crane.
 - 22) When using the Impulse•S Series AF drive on existing wound rotor motor applications oversizing the drive or installing a load reactor is suggested to avoid over-current conditions upon starting a motor.
 - 23) When supplying single phase input to the AF drive, the amperage of the drive must be derated by approximately one-half. (Consult Electromotive Systems.)
 - 24) All worm gear box hoist applications require dynamic braking resistors to avoid overvoltage conditions when lowering the hook.
 - 25) Sliding collector bars are not to be used between the drive and the motor. It must be hard wired (i.e. festoon cable).
- ** If there are any questions, or a further explanation of the above recommendations is needed, please contact Electromotive Systems at 414/783-3500 before proceeding.
- ** The above recommendations, if followed, will help to ensure trouble-free start-up and successful operation of the adjustable frequency drive when applied to overhead material handling equipment.

Spare Parts List - 230 Volts

Description	Code No.	Model No.	Part No.	Quantity
230AFD1-VG+				
Control Board	ETC67002-SXXXX	ETC67002-SXXXX	555-20-670020-0	1
Power Supply Board	ETC67010X	ETC67010X	555-20-670100-0	1
Gate Driver Board	ETP67U02X	ETP67U02X	555-25-670020-0	1
DC Bus Fuse	FU000823	CR2LS-10/UL	555-35-000823-0	1
Input Diode	SID000429	10L6P44	555-65-000429-0	1
Output Transistor	STR000417	6MBI15L-060	555-70-000417-0	1

230AFD2-VG+				
Control Board	ETC67002-SXXXX	ETC67002-SXXXX	555-20-670020-0	1
Power Supply Board	ETC67010X	ETC67010X	555-20-670100-0	1
Gate Driver Board	ETP67U23X	ETP67U23X	555-25-670230-0	1
DC Bus Fuse	FU000823	CR2LS-10/UL	555-35-000823-0	1
Input Diode	SID000433	20L6P44	555-65-000433-0	1
Output Transistor	STR000343	6MBI20-060	555-70-000343-0	1

230AFD3-VG+				
Control Board	ETC67002-SXXXX	ETC67002-SXXXX	555-20-670020-0	1
Power Supply Board	ETC67010X	ETC67010X	555-20-670100-0	1
Gate Driver Board	ETP67024X	ETP67024X	555-25-670240-0	1
Cooling Fan	FAN000175	4710NL-05W-B49	555-30-000175-0	1
DC Bus Fuse	FU000799	CR2LS-20/UL	555-35-000799-0	1
Input Diode	SID000430	6RI30E-080	555-65-000430-0	1
Output Transistor	STR000419	6MBI30L-060	555-70-000419-0	1

230AFD5-VG+				
Control Board	ETC67002-SXXXX	ETC67002-SXXXX	555-20-670020-0	1
Power Supply Board	ETC67010X	ETC67010X	555-20-670100-0	1
Gate Driver Board	ETP67U25X	ETP67U25X	555-25-670250-0	1
Cooling Fan	FAN000175	4710NL-05W-B49	555-30-000175-0	1
DC Bus Fuse	FU000791	CR2LS-30/UL	555-35-000791-0	1
Input Diode	SID000430	6RI30E-080	555-65-000430-0	1
Output Transistor	STR000420	6MBI50L-060	555-70-000420-0	1

Spare Parts List - 230 Volts (Continued)

Description	Code No.	Model No.	Part No.	Quantity
230AFD7.5-VG+				
Control Board	ETC67002-SXXXX	ETC67002-SXXXX	555-20-670020-0	1
Power Supply Board	ETC67010X	ETC67010X	555-20-670100-0	1
Gate Driver Board	ETP67026X	ETP67026X	555-25-670260-0	1
Cooling Fan	FAN000175	4710NL-05W-B49	555-30-000175-0	1
DC Bus Fuse	FU000797	CR2LS-50/UL	555-35-000797-0	1
Input Diode	SID000431	6RI50E-080	555-65-000431-0	1
Output Transistor	STR000339	MG75J2YS1	555-70-000339-0	3

230AFD10-VG+				
Control Board	ETC67002-SXXXX	ETC67002-SXXXX	555-20-670020-0	1
Power Supply Board	ETC67010X	ETC67010X	555-20-670100-0	1
Gate Driver Board	ETP67027X	ETP67027X	555-25-670270-0	1
Cooling Fan	FAN000191	4710NL-05W-B49	555-30-000191-0	1
DC Bus Fuse	FU000797	CR2LS-50/UL	555-35-000797-0	1
Input Diode	SID000432	6RI75E-080	555-65-000432-0	1
Output Transistor	STR000340	MG100J2YS1	555-70-000340-0	3

230AFD15-VG+				
Gate Driver Board	ETC067003X	ETC067003X	555-20-670030-0	1
Control Board	ETC67002-SXXXX	ETC67002-SXXXX	555-20-670020-1	1
Cooling Fan	FAN000191	THA1V-7556XV	555-30-000191-0	1
DC Bus Fuse	FU000792	CR2LS-75/UL	555-35-000792-0	1
Input Diode	SID000291	100L6P41	555-65-000291-0	1
Output Transistor	STR000364	MG150J2YS1	555-70-000364-0	3

230AFD20-VG+				
Gate Driver Board	ETC067003X	ETC067003X	555-20-670030-0	1
Control Board	ETC67002-SXXXX	ETC67002-SXXXX	555-20-670020-1	1
Cooling Fan	FAN000191	THA1V-7556XV	555-30-000191-0	1
DC Bus Fuse	FU000807	CR2LS-100	555-35-000807-0	1
Input Diode	SID000412	110L2G43	555-65-000412-0	3
Output Transistor	STR000365	MG200J2YS1	555-70-000365-0	3

Spare Parts List - 230 Volts (Continued)

Description	Code No.	Model No.	Part No.	Quantity
230AFD25-VG+				
Gate Driver Board	ETC067004X	ETC067004X	555-20-670040-0	1
Control Board	ETC67002-SXXXX	ETC67002-SXXXX	555-20-60700201	1
Cooling Fan	FAN000191	THA1V-U7556MX	555-30-000191-0	1
DC Bus Fuse	FU000809	A50P-150	555-35-000809-0	1
Input Diode	SID000412	110L2G43	555-65-000412-0	3
Output Transistor	STR000374	CM300HA-12	555-70-000374-0	6

230AFD30-VG+				
Gate Driver Board	ETC67004X	ETC67004X	555-20-670040-0	1
Control Board	ETC67002-SXXXX	ETC67002-SXXXX	555-20-670020-0	1
Cooling Fan	FAN000191	THA1V-U7556MX	555-30-000191-0	1
DC Bus Fuse	FU000809	CR2L-150	555-35-000809-0	1
Input Diode	SID000412	110L2G43	555-65-000412-0	3
Output Transistor	STR000374	CM300HA-12	555-70-000374-0	6

230AFD50-VG+				
Gate Driver Board	ETC670150	ETC670150	555-20-670150-0	1
Control Board	ETC67002-SXXXX	ETC67002-SXXXX	555-20-670020-0	1
Cooling Fan	FAN000191	THA1V-U7556MX	555-30-000191-0	2
DC Bus Fuse	FU000811	A50P275	555-35-000811-0	1
Input Diode	SID000447	160L2G43	555-65-000447-0	6
Output Transistor	STR000316	CM500HA-H	555-70-000316-0	6

230AFD75-VG+				
Gate Driver Board	ETC670160	ETC670160	555-20-670160-0	1
Control Board	ETC67002-SXXXX	ETC67002-SXXXX	555-20-670020-0	1
Cooling Fan	FAN000191	THA1V-U7556MX	555-30-000191-0	2
DC Bus Fuse	FU000938	A50P400	555-35-000938-0	1
Input Diode	SID000447	160L2G43	555-65-000447-0	6
Output Transistor	STR000456	CM300HA-12E	555-70-000456-0	12
Sub Driver Board	ETC670450	ETC670450	555-20-670450-0	1

230AFD100-VG+				
Gate Driver Board	ETC670170	ETC670170	555-20-670170-0	1
Control Board	ETC67002-SXXXX	ETC67002-SXXXX	555-20-670020-0	1
Cooling Fan	FAN000191	THA1V-U7556MX	555-30-000191-0	2
DC Bus Fuse	FU000926	A50P600	555-35-000926-0	1
Input Diode	SID000447	160L2G43	555-65-000447-0	9
Output Transistor	STR000457	CM400HA-12E	555-70-000457-0	12
Sub Driver Board	ETC670450	ETC670450	555-20-670450-0	1

Spare Parts List - 460 Volts

Description	Code No.	Model No.	Part No.	Quantity
460AFD5-VG+				
Control Board	ETC607002X-SXXXX	ETC607002X-SXXXX	555-20-607002-0	1
Power Supply Board	ETC67011X	ETC67011X	555-20-670110-0	1
Gate Driver Board	ETP67U30X	ETP67U30X	555-25-670300-0	1
Cooling Fan	FAN000175	4710NL-05W-B49	555-30-000175-0	1
Fuse	FU000853	A70P30	555-35-000853-0	1
Input Diode	SID000435	30Q6P42	555-65-000435-0	1
Output Transistor	STR000463	2MBI25L-120	555-70-000463-0	3

460AFD7.5-VG+				
Control Board	ETC607002X-SXXXX	ETC607002X-SXXXX	555-20-607002-0	1
Power Supply Board	ETC67011X	ETC67011X	555-20-670110-0	1
Gate Driver Board	ETP67U31X	ETP67U31X	555-25-670310-0	1
Cooling Fan	FAN000175	4710NL-05W-B49	555-30-000175-0	1
Fuse	FU000853	A70P30	555-35-000853-0	1
Input Diode	SID000435	30Q6P42	555-65-000435-0	1
Output Transistor	STR000462	2MBI50L-120	555-70-000462-0	3

460AFD10-VG+				
Control Board	ETC607002X-SXXXX	ETC607002X-SXXXX	555-20-607002-0	1
Power Supply Board	ETC67011X	ETC67011X	555-20-670110-0	1
Gate Driver Board	ETP67U31X	ETP67U31X	555-25-670310-0	1
Cooling Fan	FAN000175	4710NL-05W-B49	555-30-000175-0	1
Fuse	FU000853	A70P30	555-35-000853-0	1
Input Diode	SID000435	30Q6P42	555-65-000435-0	1
Output Transistor	STR000462	2MBI50L-120	555-70-000462-0	3

460AFD15-VG+				
Control Board	ETC607002X-SXXXX	ETC607002X-SXXXX	555-20-607002-0	1
Gate Driver Board	ETC67005X	ETC67005X	555-20-670050-0	1
Cooling Fan	FAN000190	THA1V-UH4556M	555-30-000190-0	1
Fuse	FU000935	CR6L-50/UL	555-35-000935-0	1
Input Diode	SID000407	50Q6P43	555-65-000407-0	1
Output Transistor	STR000353	MG75Q2YS1	555-70-000353-0	3

Spare Parts List - 460 Volts (Continued)

Description	Code No.	Model No.	Part No.	Quantity
460AFD20-VG+				
Control Board	ETC607002X-SXXXX	ETC607002X-SXXXX	555-20-607002-0	1
Gate Driver Board	ETC67005X	ETC67005X	555-20-670050-0	1
Cooling Fan	FAN000190	THA1V-UH4556M	555-30-000190-0	1
Fuse	FU000935	CR6L-50/UL	555-35-000935-0	1
Input Diode	SID000443	100Q6P43	555-65-000443-0	1
Output Transistor	STR000354	MG100Q2YS1	555-70-000354-0	3

460AFD25-VG+				
Control Board	ETC607002X-SXXXX	ETC607002X-SXXXX	555-20-607002-0	1
Gate Driver Board	ETC67006X	ETC67006X	555-20-670060-0	1
Cooling Fan	FAN000191	THA1V-U7556MX	555-30-000191-0	1
Fuse	FU000927	CR6L-100/UL	555-35-000927-0	1
Input Diode	SID000408	100Q6P43	555-65-000408-0	1
Output Transistor	STR000355	MG150Q2YS1	555-70-000355-0	3

460AFD30-VG+				
Control Board	ETC607002X-SXXXX	ETC607002X-SXXXX	555-20-607002-0	1
Gate Driver Board	ETC67006X	ETC67006X	555-20-670060-0	1
Cooling Fan	FAN000191	THA1V-U7556MX	555-30-000191-0	1
Fuse	FU000927	CR6L-100/UL	555-35-000927-0	1
Input Diode	SID000408	100Q6P43	555-65-000408-0	1
Output Transistor	STR000355	MG150Q2YS1	555-70-000355-0	3

460AFD40-VG+				
Control Board	ETC607002X-SXXXX	ETC607002X-SXXXX	555-20-607002-0	1
Gate Driver Fan	ETC67020X	ETC67020X	555-20-670200-0	1
Cooling Fan	FAN000191	THA1V-U7556MX	555-30-000191-0	2
Fuse	FU000927	CR6L-100/UL	555-35-000927-0	1
Input Diode	SID000409	110Q2G43	555-65-000409-0	3
Output Transistor	STR000376	CM300HA-24	555-70-000376-0	6

460AFD50-VG+				
Control Board	ETC607002X-SXXXX	ETC607002X-SXXXX	555-20-607002-0	1
Gate Driver Fan	ETC67020X	ETC67020X	555-20-670200-0	1
Cooling Fan	FAN000191	THA1V-U7556MX	555-30-000191-0	2
DC Bus Fuse	FU000928	CR6L-150/UL	555-35-000928-0	1
Input Diode	SID000409	110Q2G43	555-65-000409-0	3
Output Transistor	STR000376	CM300HA-24	555-70-000376-0	6

Spare Parts List - 460 Volts (Continued)

Description	Code No.	Model No.	Part No.	Quantity
460AFD60-VG+				
Control Board	ETC607002X-SYYYY	ETC607002X-SYYYY	555-20-607002-0	1
Gate Driver Board	ETC67026X	ETC67026X	555-20-670260-0	1
Cooling Fan	FAN000191	THA1V-U7556MX	555-30-000191-0	1
DC Bus Fuse	FU000928	CR6L-150/UL	555-35-000928-0	1
Input Diode	SID000409	110Q2G43	555-65-000409-0	3
Output Transistor	STR000376	CM300HA-24	555-75-000376-0	6

460AFD75-VG+				
Control Board	ETC607002X-SYYYY	ETC607002X-SYYYY	555-20-607002-0	1
Gate Driver Board	ETC67030X	ETC67030X	555-20-670300-0	1
Cooling Fan	FAN000191	THA1V-U7556MX	555-30-000191-0	2
DC Bus Fuse	FU000929	CR6L-200/UL	555-35-000929-0	1
Input Diode	SID000410	160Q2G43	555-65-000410-0	6
Output Transistor	STR000385	CM400HA-24	555-70-000385-0	6

460AFD100-VG+				
Control Board	ETC607002X-SYYYY	ETC607002X-SYYYY	555-20-607002-0	1
Gate Driver Board	ETC67031X	ETC67031X	555-20-670310-0	1
Cooling Fan	FAN000191	THA1V-U7556MX	555-30-000191-0	2
DC Bus Fuse	FU000930	CR6L-300/UL	555-35-000930-0	1
Input Diode	SID000410	160Q2G43	555-65-000410-0	6
Output Transistor	STR000385	CM400HA-24	555-70-000385-0	6

460AFD150-VG+				
Control Board	ETC607002X-SYYYY	ETC607002X-SYYYY	555-20-607002-0	1
Gate Driver Board	ETC67035X	ETC67035X	555-20-670350-0	1
Cooling Fan	FAN000191	THA1V-U7556MX	555-30-000191-0	2
DC Bus Fuse	FU000803	A70P350	555-35-000803-0	1
Input Diode	SID000410	160Q2G43	555-65-000410-0	9
Output Transistor	STR000425	CM300HA-24	555-70-000425-0	12

Spare Parts List - 460 Volts (Continued)

Description	Code No.	Model No.	Part No.	Quantity
460AFD200-VG+				
Control Board	ETC607002X-SYYYY	ETC607002X-SYYYY	555-20-607002-0	1
Gate Driver Board	ETC67039X	ETC67039X	555-20-670390-0	1
Cooling Fan	FAN000191	THA1V-U7556MX	555-30-000191-0	2
DC Bus Fuse	FU000924	A70P600	555-35-000924-0	1
Input Diode	SID000411	RM250DZ-25	555-65-000411-0	2
Output Transistor	STR000455	CM400HA-24	555-70-000455-0	6

460AFD300-VG+				
Control Board	ETC607002X-SYYYY	ETC607002X-SYYYY	555-20-607002-0	1
Main Driver Board	ETC67037X	ETC67037X	555-20-670370-0	1
Sub Driver Board	ETC67038X	ETC67038X	555-20-670380-0	1
Drive Unit	ETJ273X	ETJ273X	555-20-273000-0	1
Fan Unit	EUX350X	EUX350X	555-30-350000-0	1
Main Diode Circuit	SID000411	RM250DZ-24	555-65-000411-0	2

460AFD400-VG+				
Control Board	ETC607002X-SYYYY	ETC607002X-SYYYY	555-20-607002-0	1
Main Driver Board	ETC67041X	ETC67041X	555-20-670410-0	1
Sub Driver Board	ETC67042X	ETC67042X	555-20-670420-0	1
Drive Unit	ETJ274X	ETJ274X	555-20-274000-0	1
Fan Unit	EUX350X	EUX350X	555-30-350000-0	1
Main Diode Circuit	SID000411	RM250DZ-24	555-65-000411-0	2