

IMPULSE • G+/VG+ SERIES 3 MODBUS PLUS®

Drive Communication Instruction Manual



MAGNETEK
MATERIAL HANDLING

Electromotive

Part Number: 144-42141

July 2006

© Copyright 2006 Magnetek Material Handling

Technical References

Refer to the following publications for information about the IMPULSE Series 3:

- IMPULSE • G+ Series 3 Instructional Manual
- IMPULSE • VG+ Series 3 Instructional Manual

Refer to the following Modicon publications for technical information about Modicon, Modbus Plus communications and Programmable Controllers:

- Modicon Modbus Plus Network Planning and Installation Guide
Publication GM-MBPL-001
- Modicon Ladder Logic Block Library User Guide
Publication 840 USE 101 00

Technical Support

Magnetek offers support services for drive installation and programming. Magnetek will not be held responsible for supporting master devices that were not provided by Magnetek.

For technical support please contact:
1-866-MAG-SERV
(1-866-624-7378)

Table of Contents

	Technical References / Technical Support	i
Chapter 1	Introducing the Modbus Plus Network Overview Modbus Plus Network Introduction How the Network Operates	1-1
Chapter 2	Getting Started IMPULSE Series 3 and Modbus Plus Modbus Plus Communications Kit	2-1
Chapter 3	Installation of MB+ Board Installation Notes Installation of the MB+ Board into the IMPULSE Series 3 MB+ Board Configuration Modbus Plus Communication Connection	3-1
Chapter 4	Establishing Communications IMPULSE Series 3 Parameter Settings Communication Initialization Communication Error Detection MB+ Network	4-1
Chapter 5	Modbus Plus MSTR Function Modbus Plus MSTR Function MSTR Control Block MSTR Data Block MSTR Area Size	5-1
Chapter 6	Basic MSTR Functions Types of Data Write Function Read Function	6-1
Chapter 7	Special Modbus Plus Functions Executing a Global Write Function Enabling Global Write Executing a Global Read Function Using the 'ACCEPT' and 'ENTER' Commands Writing to the Global Frequency Reference Multiplier Origin of the RUN/STOP and Frequency Reference Commands Using the IMPULSE Series 3 Drive Register 001h	7-1
Chapter 8	Diagnostics and Troubleshooting Troubleshooting Information Diagnostic LED (D2) MSTR Error Codes IMPULSE Series 3 Failure Codes	8-1

Chapter 9	Examples Example #1 Write RUN/STOP and Frequency Reference Example #2 Read Output Frequency Example #3 Read Global Data Example #4 Write Global RUN/STOP and Frequency Reference Example #5 Write Acceleration and Deceleration Times Example #6 Write a Global Frequency Reference Multiplier Example #7 Read Drive Parameters Example #8 Write Drive Parameters Example #9 Read Drive Status Register	9-1
Chapter 10	Application Notes Register Types Through-put Limitations	10-1
Appendix A	Data Registers Global Data Command Data Monitor Data Drive Parameter Data Special Data	A-1

Chapter 1

Introducing the MB+ Network

- Overview
- MB+ Network Introduction
- How the Network Operates

Note: The AC Drive referenced in this manual may be named IMPULSE Series 3. These are physically the same drive. This manual will use the name IMPULSE Series 3 hereafter.

Overview

This manual describes the installation of a MODBUS PLUS Communication Kit, configuration of the MB+ board and programming of the master (MSTR) function blocks, necessary for network nodes (IMPULSE Series 3 drives) to process message transactions.

This manual should be used for personnel involved in developing, installing, or troubleshooting drives communicating via the MODBUS PLUS network (also referred to in this manual as the MB+ network).

MODBUS PLUS Network Introduction

MODBUS PLUS is a communications system designed for industrial control applications. MODBUS PLUS is a LAN (Local Area Network) communication scheme, which allows a host PLC to communicate with slave devices (nodes) on a network. Each network supports up to 64 addressable node devices, at a data transfer rate of 1 MegaBaud.

With a MB+ board installed, an IMPULSE Series 3 can be configured as one of the 64 nodes. The connection between nodes on the LAN is achieved using a shielded, twisted-pair cable between each node.

How the Network Operates

Network nodes are identified by addresses assigned by the system designer. Each device is independent and its node address is unique. Duplicate node addresses are not allowed. Addresses are within a range of 1 to 64, and are not required to be sequential.

How Nodes Access the Network

Network nodes function as peer members of a logical ring, gaining access to the network upon receipt of a token.

Initialization: When a network is initialized, each node becomes aware of the other active nodes. Each node builds a table identifying the other nodes, and initial ownership of the token is established.

Token Hold: While holding the token, a node initiates message transactions with other nodes. Each message contains routing fields defining its source and destination on the network.

Token Pass: While passing the token, a node can write into a global database, for broadcast to all nodes on the network. Other nodes monitor the token pass and can extract the global data if programmed to do so.

Token Rotation Sequence

The token rotation sequence is established by node address. Token rotation begins at the network's lowest-addressed active node, proceeding consecutively through each higher-addressed node, until the highest-addressed active node receives the token. That node then passes the token to the lowest one to begin a new rotation. This rotation occurs without respect to the physical proximity of one node to another.

If a node leaves the network, a new token passing sequence is established, typically within 100 milliseconds. New nodes joining the network are included in the correct address sequence for passing the token, typically within 5 seconds.

When multiple networks are joined by bridges, tokens are not passed through a bridge device from one network to another. Each network performs its token passing process independently of other networks.

Point to Point Message Transactions

While a node holds the token, it may send application messages. If the node does not have any messages to transmit, it will pass the token. Each message can contain up to 100 controller registers consisting of 16-bit words of data. The other node(s) monitor the network for incoming messages.

When a node receives a message, it sends an immediate acknowledgment to the originating node. If the message is a request for data, the receiving node will begin assembling the requested data into a reply message. When the message is ready, it will be transmitted to the requester when the node receives a subsequent token granting it access to transmit. After a node sends all of its messages, the node passes the token to the next node address in sequence.

The IMPULSE Series 3 drive is capable of participating as a node on a MODBUS PLUS communications network.

Chapter 2

Getting Started

- **IMPULSE Series 3 and Modbus Plus**
- **Modbus Plus Communications Kit**

IMPULSE Series 3 and Modbus Plus

The IMPULSE Series 3 AC drive accepts interface boards. Installation of a Modbus Plus Communication Kit ensures the IMPULSE Series 3 is a MODICON certified ModConnect® partner with direct connection to Modbus Plus.

NOTE
This interface board will only operate with a particular version of drive software. To check software use U1-14. A “ CPF 06 ” fault will appear on the display, if the wrong version of drive software is installed.

The Modbus Plus Communication Kit, Model No., CMG5MB+ provides a Modbus Plus Serial Communication Board Interface option (the MB+ board) which allows operation, status monitoring, and programming of a IMPULSE Series 3 drive from a MODICON Programmable Controller using the Modbus Plus local area network.

The Modbus Plus Communication Kit is available as a factory installed option for the IMPULSE Series 3 drive.

Modbus Plus Communication Kit

Each drive must have its own Modbus Plus kit installed to communicate via Modbus Plus. The CMG5MB+ Modbus Plus Communication Kit consists of the following items:

- MB+ board.
A printed circuit board (see Figure 2-1) which mounts at connector 2CN inside the IMPULSE Series 3.
- IMPULSE Series 3 / Modbus Plus Technical Manual

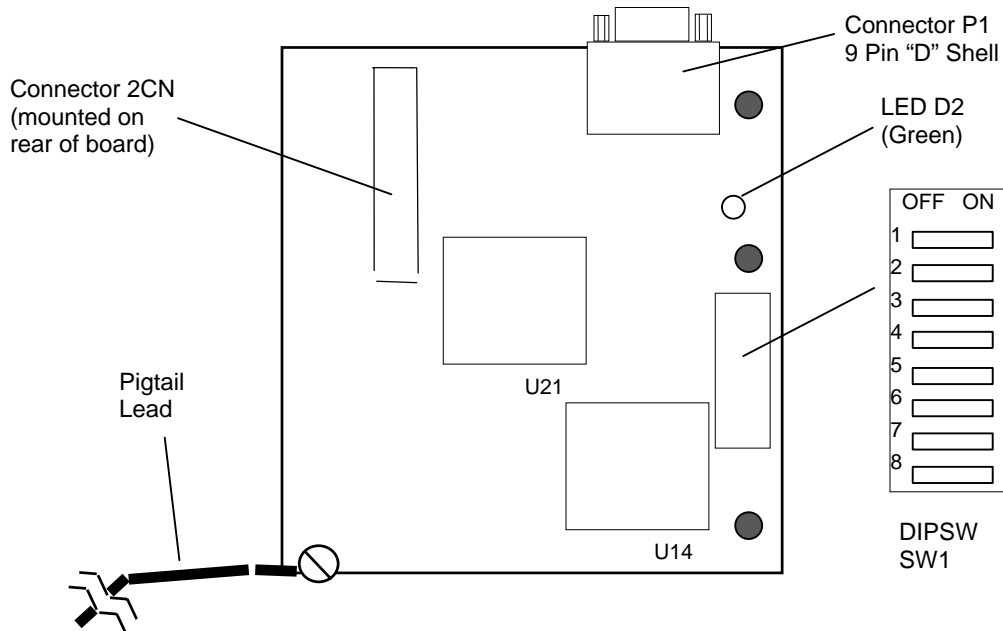

Figure 2-1. MB+ Board

Chapter 3

Installation of the MB+ Board

- Installation Notes
- Installation of the MB+ Board into the IMPULSE Series 3
- MB+ Board Configuration
- Modbus Plus Communication Connection

Installation Notes

This section provides several installation notes for the MB+ board. This option should be installed by a **technically qualified individual** who is familiar with this type of equipment and the hazards involved. A cable to connect the IMPULSE Series 3 to the MB+ network is required. MODICON offers a full line of cables and connectors for use with Modbus Plus network devices.

The MB+ board employs CMOS technology, which may be damaged by static electricity. Use proper electrostatic discharge (ESD) procedures when handling the MB+ board.



CAUTION: Failure to follow these installation steps may cause equipment damage or personnel injury.



WARNING: Hazardous voltage can cause severe injury or death. Lock all power sources feeding the drive in the “OFF” position. Ensure that the CHARGE lamp inside the unit is off, before installing the MB+ board.

NOTE
This interface board will only operate with a particular version of drive software. To check software use U1-14. A “ CPF 06 ” fault will appear on the display, if the wrong version of drive software is installed.

Installing the MB+ Board into the IMPULSE Series 3

Please review this procedure fully, prior to beginning the MB+ board installation.

1. Turn the main power OFF to the drive, and wait the specified length of time shown on the front cover.
2. Remove the front cover of the drive by removing two Phillips screws or by gently pressing the specially marked indentations on the sides of the cover. (Note: The size of the drive will determine the appropriate method.)
3. Verify the CHARGE lamp is “OFF”.
4. Orient the MB+ board as shown in Figure 3-1.
5. Position the MB+ board's 2CN connector (on the underside of the printed circuit board) to mate with the matching 2CN connector on the drive control board.

While aligning the connectors, position the three plastic standoffs on the control board to slip through the holes on the MB+ board.

6. Ensuring proper alignment, lower the MB+ board into position and press carefully until the board is firmly seated on the standoffs, and the 2CN connectors are engaged.

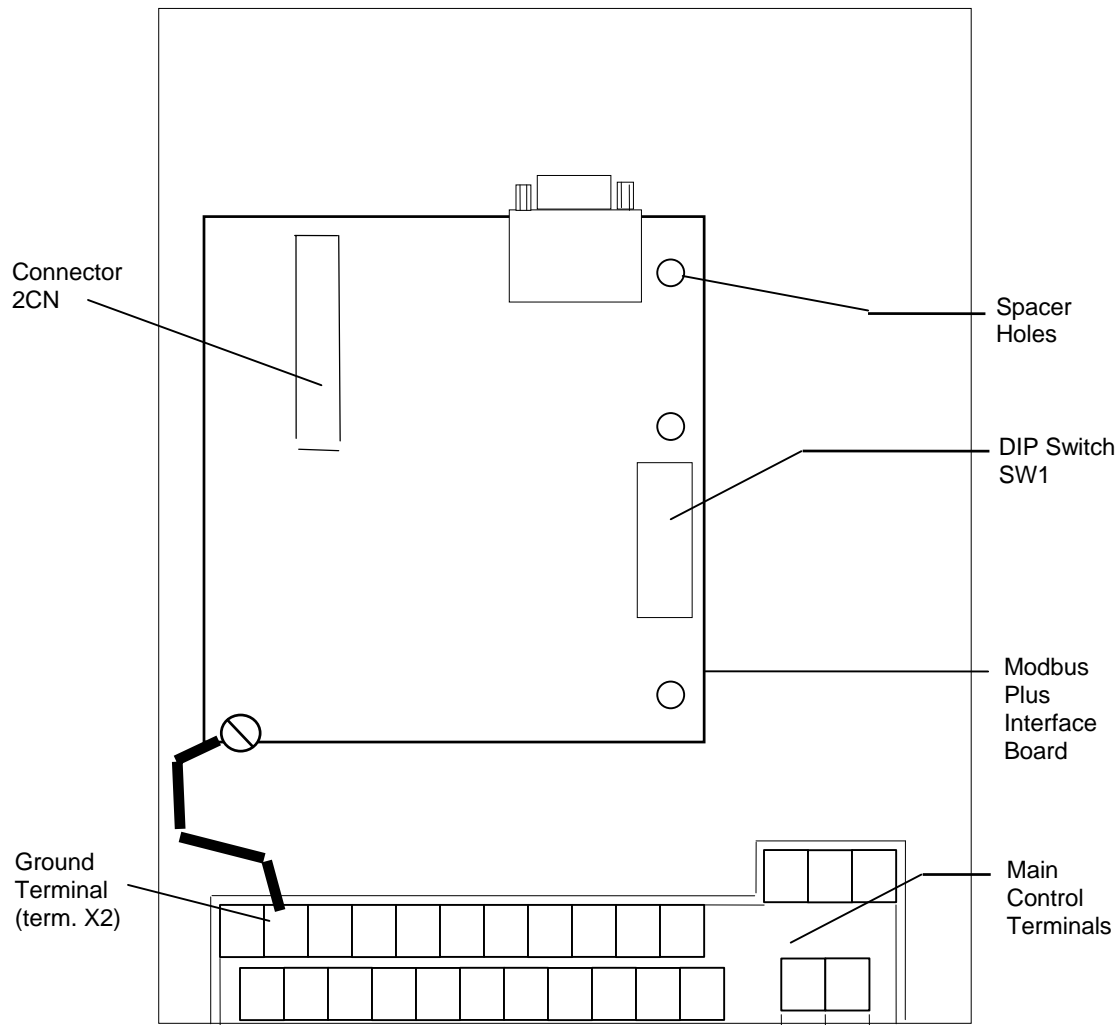

Figure 3-1. MB+ Board Mounting Position

7. Locate the green grounding wire with mounting lug on the MB+ board. Route this wire to the lower corner of the drive control board.
8. Connect the green wire (labeled "E") to terminal X2 on the drive.

NOTE: You have completed the mechanical installation of the MB+ board. Proceed to the MB+ board configuration prior to applying input power or replacing the IMPULSE Series 3 front cover.

MB+ Board Configuration

The MB+ board requires setup prior to operation. 8-position Dip switch SW1 must be set prior to the application of input AC power to the IMPULSE Series 3. The states of these switches are read only on power-up.

The MB+ board SW1 switches are defined in the following table:

Switch Number	Switch Function
1	Drive Node Address - bit 0 / LSB
2	Drive Node Address - bit 1
3	Drive Node Address - bit 2
4	Drive Node Address - bit 3
5	Drive Node Address - bit 4
6	Drive Node Address - bit 5 / MSB
7	Cable Loss Function
8	Global Read Function

Switches 1 through 6 are used to setup the Modbus Plus network address of the drive (node). The network allows addressing from 1 to 64. The nodes do not have to be sequential, however, two nodes on the network may NOT have the same address. The table on the following page illustrates the positions of SW1-1 through SW1-6 for each corresponding Modbus Plus address.

An example of setting SW1 to MB+ network node# 4 and enabling global reads plus cable-loss checking:

	OFF	ON	
1	<input type="checkbox"/>	<input type="checkbox"/>	OFF = set for node address 4
2	<input type="checkbox"/>	<input type="checkbox"/>	OFF = set for node address 4
3	<input type="checkbox"/>	<input type="checkbox"/>	ON = set for node address 4
4	<input type="checkbox"/>	<input type="checkbox"/>	ON = set for node address 4
5	<input type="checkbox"/>	<input type="checkbox"/>	ON = set for node address 4
6	<input type="checkbox"/>	<input type="checkbox"/>	ON = set to node address 4
7	<input type="checkbox"/>	<input type="checkbox"/>	ON = cable loss checking
8	<input type="checkbox"/>	<input type="checkbox"/>	ON = global read enabled

MB+ Network Node Address	SW1 Position 0=off 1=on					
	6	5	4	3	2	1
01	1	1	1	1	1	1
02	1	1	1	1	1	0
03	1	1	1	1	0	1
04	1	1	1	1	0	0
05	1	1	1	0	1	1
06	1	1	1	0	1	0
07	1	1	1	0	0	1
08	1	1	1	0	0	0
09	1	1	0	1	1	1
10	1	1	0	1	1	0
11	1	1	0	1	0	1
12	1	1	0	1	0	0
13	1	1	0	0	1	1
14	1	1	0	0	1	0
15	1	1	0	0	0	1
16	1	1	0	0	0	0
17	1	0	1	1	1	1
18	1	0	1	1	1	0
19	1	0	1	1	0	1
20	1	0	1	1	0	0
21	1	0	1	0	1	1
22	1	0	1	0	1	0
23	1	0	1	0	0	1
24	1	0	1	0	0	0
25	1	0	0	1	1	1
26	1	0	0	1	1	0
27	1	0	0	1	0	1
28	1	0	0	1	0	0
29	1	0	0	0	1	1
30	1	0	0	0	1	0
31	1	0	0	0	0	1
32	1	0	0	0	0	0
33	0	1	1	1	1	1
34	0	1	1	1	1	0
35	0	1	1	1	0	1
36	0	1	1	1	0	0
37	0	1	1	0	1	1
38	0	1	1	0	1	0
39	0	1	1	0	0	1
40	0	1	1	0	0	0
41	0	1	0	1	1	1
42	0	1	0	1	1	0
43	0	1	0	1	0	1
44	0	1	0	1	0	0
45	0	1	0	0	1	1
46	0	1	0	0	1	0
47	0	1	0	0	0	1
48	0	1	0	0	0	0
49	0	0	1	1	1	1
50	0	0	1	1	1	0
51	0	0	1	1	0	1
52	0	0	1	1	0	0
53	0	0	1	0	1	1
54	0	0	1	0	1	0
55	0	0	1	0	0	1
56	0	0	1	0	0	0
57	0	0	0	1	1	1
58	0	0	0	1	1	0
59	0	0	0	1	0	1
60	0	0	0	1	0	0
61	0	0	0	0	1	1
62	0	0	0	0	1	0
63	0	0	0	0	0	1
64	0	0	0	0	0	0

Cable Loss Detection

A cable loss occurs when the 'master' (controlling node which initiates transactions) drops out of the token rotation sequence. The MB+ board continuously monitors the network for the 'master' node.

Switch 7 is used to enable the Cable Loss Detection.

Function Description	MB+ SW1-7 Position
Cable Loss Detection Enabled	1 = ON
Cable Loss Detection Disabled	0 = OFF

When the Cable Loss Detection is enabled, a communication loss will generate a fault and display an " **EF0** " fault code on the Digital Operator.

How the IMPULSE Series 3 handles this fault is configured by setting of drive parameters F6-03 and F6-02.

Cable Loss Detection is not activated immediately on power-up. The function is enabled (with SW1-7 ON) after the first command (non-global) is given to the drive.

A Cable Loss Fault (**EF0**) is a configurable fault using the F6-xx parameters.
⇒ If configured to F6-03 (alarm only) and F6-02 (during run), the cable loss fault (**EF0**) is disabled even with SW1-7 ON.

Global Read Function

Switch 8 is used to enable the Global Read Function.

Function Description	MB+ SW1-8 Position
Global Read Function Enabled	1 = ON
Global Read Function Disabled	0 = OFF

When the Global Read Function is enabled, the drive provides eight registers of data to the PLC on the network. The drive automatically and continuously sends this Global Read Data when it has the token. The PLC only reads this data when requested by the ladder logic (through the execution of a Global Read MSTR Function). Chapter 7 expands on the details of the Global Read Function.

Note: The Global Write Function is not affected by the setting of SW1-8.

Modbus Plus Communication Connection

Communication between an IMPULSE Series 3 drive and the MB+ network requires a physical connection from your drive to the MB+ network. Connect your network communication cable into P1 (9-pin "D" shell) on the MB+ board. Modicon offers cables and connectors for the MB+ network.

Modicon Modbus Plus Wiring:

The recommended cable for MB+ network connections is Belden 9841. This cable consists of:

- One twisted signal pair: blue/white
- Drain wire: bare
- Overall aluminized mylar shield

This cable is available from Modicon as the following part numbers:

- 97-9841-100 MBPlus 100 Foot Reel
- 97-9841-500 MBPlus 500 Foot Reel
- 97-9841-01K MBPlus 1000 Foot Reel

Two types of connectors are available from Modicon for connecting devices to the network. Each in-line drop requires an in-line connector. The two drops at the ends of the Modbus Plus network cable each require a terminating connector. When the terminating connectors are installed on the two extreme ends of the cable, no other termination is required.

- AS-MBKT-085 MBPlus In-line Connector (quantity 1)
- AS-MBKT-185 MBPlus Terminating Connector (quantity 1)
- AS-MBPL-001 MBPlus Connector Assembly Tool

Route the Modbus Plus cable out of the bottom of the drive enclosure. Select a cable routing method to protect the cable from physical damage and potential electrical interference sources.

<p>Note: Avoid sources of electrical interference capable of inducing noise into the cable. If a cable must cross power wiring, it must cross only at a right angle.</p>

Chapter 4

Establishing Communications

- IMPULSE Series 3 Parameter Settings
- Communication Initialization
- Communication Error Detection
- MB+ Network

IMPULSE Series 3 Parameter Settings

The drive can be configured to receive operation signals (Run, Stop, Forward, Reverse, ...) from the MB+ network, serial communication, the external drive terminals, or the Digital Operator. IMPULSE Series 3 Drive Register b3-02 (18Eh) is used to setup the source of the operation signals. The following table indicates the possible configurations for the origin of the operation signals:

RUN / STOP	
b3-02	Commands from:
0	Digital Operator
1	Terminal
2	Serial Communication
3	Option PCB (MB+ board)

The drive can be configured to receive a frequency reference from the MB+ network, serial communication, the external drive terminals, or the Digital Operator. IMPULSE Series 3 Drive Register b3-01 (18Dh) is used to setup the source of the frequency reference. The following table indicates the possible configurations for the origin of the frequency reference:

FREQUENCY REFERENCE	
b3-01	Commands from:
0	Digital Operator
1	Terminal
2	Serial Communication
3	Option PCB (MB+ board)
4 (H6-01)	Pulse Input

The value of IMPULSE Series 3 Drive Register b3-01 (18Dh) and b3-02 (18Eh) may be stored in Non-Volatile RAM memory on the drive by use of the ENTER command. After the value has been 'entered', that value will be retained if the drive unit is powered down.

Although the settings of b3-01 (18Dh) and b3-02 (18Eh) set the origin of the operation and frequency reference commands, many commands may still be functional from an alternative source.

Communication Initialization

When input power is applied to the drive, it will recognize the presence of the MB+ board, and prepare for serial communications.

The green LED indicator (D2) on the MB+ board is used to indicate the MB+ board has established communications with a PLC. The green LED will react as follows:

Rapid Blink rate = This node is operating normally. It is successfully receiving and passing the token.

(Additional blink patterns shown in Chapter 8, Diagnostics and Troubleshooting.)

Communication Error Detection

If a communication fault occurs, control from the PLC is not possible. The IMPULSE Series 3 drive will display an "EF0 - DDS External Flt" fault and will then operate according the settings of parameters F6-02 and F6-03.

The flashing patterns of LED D2 on the MB+ board are described in Chapter 8 of this manual.

F6-02	Drive Detection of "EF0" Fault
0	Fault always detected
1	Fault detected during run

F6-03	Drive Reaction to Communication Error Detection
0	"EF0" is displayed on the Digital Operator, the fault contact closes, and the drive decelerates the motor to ramp to a stop.
1	"EF0" is displayed on the Digital Operator, the fault contact closes, and the motor coasts to stop (not controlled by the drive).
2	"EF0" is displayed on the Digital Operator, the fault contact closes, and the drive does a fast stop.
3	"EF0" is displayed on the Digital Operator, the fault contact closes, and the stop method is determined by B3-03.
4	"EF0" is displayed on the Digital Operator. The fault contact does not close, and the drive continues to run at its last state. (Alarm Only)

MB+ Network

A single MB+ network can have up to 64 addressable devices (nodes). Each device requires a unique node address. One node is allocated for each IMPULSE Series 3 drive with its MB+ board installed. No duplicate node addresses should exist.

Up to 32 nodes can be connected directly to the network bus over a length of 1500 feet (450 meters). Repeater devices can extend the cable distance a maximum of 6000 feet (1800 meters), and node count of 64. If more than 64 devices are to be connected, multiple networks can be joined through “bridge devices”. Nodes address each other across a bridge device by specifying routing paths. The routing path is embedded in the control block section of the Modbus Plus MSTR function block and is sent from the originating node. Modbus Plus message routing is described in detail under “MSTR Control Block” in Chapter 5.

Chapter 5

Modbus Plus MSTR Function

- Modbus Plus MSTR Function
- MSTR Control Block
- MSTR Data Block
- MSTR Area Size

Modbus Plus MSTR Function

When using a Modicon programmable logic controller to access registers from a node on the MB+ network, an MSTR function block must be used. All Modicon controllers supporting the Modbus Plus communication protocol have a MSTR (Master) function block. The MSTR function block is used to initiate Modbus Plus message transactions. Each type of network transaction has an associated operation code. The Modbus Plus transactions supported by the IMPULSE Series 3 drives are:

MSTR Function	Operation Code
Write Data	1
Read Data	2
Write Global Data	5
Read Global Data	6

The MSTR function block is a three section function block as shown below:

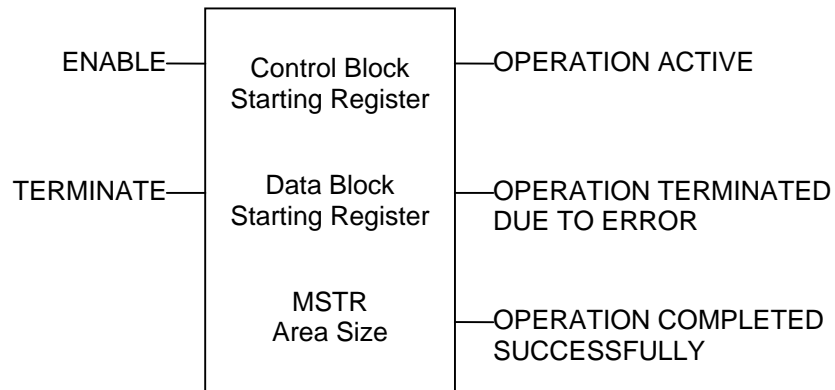

The MSTR function block has two control inputs. The ENABLE input enables the instruction when it is ON. The TERMINATE input terminates the active operation when it is ON.

The MSTR function block can produce three possible outputs. The OPERATION ACTIVE output goes ON while the instruction is active. The OPERATION TERMINATED output goes ON if an error occurs during the transaction or if the MSTR operation is terminated prior to completion. The OPERATION SUCCESSFUL output goes ON when an MSTR operation has been completed successfully.

When inserting a MSTR function block into the ladder logic, three pieces of data are required:

1. Control Block starting address
2. Data Block starting address
3. Maximum number of Data Block registers

MSTR Control Block

The data entered in the top section of the MSTR function block is the address of the first register in the Control Block. The Control Block is a sequential group of nine registers in the PLC. The Control Block registers are used to transfer information between the ladder logic and the MSTR function block.

Information transferred from the ladder logic to the MSTR include:

- the type of Modbus Plus transaction (read, write, global write, global read)
- the address of the drive (node)
- the data code of the first register to be transferred
- the number of registers that will be transferred
- the routing path to the drive

Information transferred from the MSTR to the ladder logic include:

- the status of the Modbus Plus transaction.

The Control Block registers must have an address in the 4X range.

The Control Block registers are defined as:

CONTROL BLOCK		
Control Block Offset	MSTR Word Description	Comments
4X + 0	Operation Code	1 = Multiple Register Write 5= Write Global Data 2 = Multiple Register Read 6= Read Global Data
4X + 1	Network Error Code	Communication link status - returned from MB+ link
4X + 2	Number of Registers	Length of the data area
4X + 3	Drive Register Data Code	Register of the requested/written information
4X + 4	Routing 1	Routing register #1 / local network
4X + 5	Routing 2	Routing register #2
4X + 6	Routing 3	Routing register #3
4X + 7	Routing 4	Routing register #4
4X + 8	Routing 5	Routing register #5

The Operation Code (4X + 0) is used by the ladder logic to indicate the type of transaction that will be performed. Valid operation codes are defined in the following table:

MSTR Function	Operation Code
Write Data	1
Read Data	2
Write Global Data	5
Read Global Data	6

The Network Error Code (4X + 1) is used by the MSTR to indicate the status of the transaction. If any error occurs during the transaction, an error code will be transferred into this register. A list of MSTR error codes can be found in Chapter 8.

Number of Registers (4X + 2) is used by the ladder logic to indicate the number of registers that will be transferred during this transaction. When writing multiple registers to the drive, the number in this register will indicate how many sequential registers will be written to. When reading multiple registers from the drive, the number in this register will indicate how many sequential registers will be read from.

The Drive Register Data Code (4X + 3) is used by the ladder logic to indicate the address of the drive register in which to read/write. This information is called the 'Data Code'. When 4X + 2 register value is 1, there will only be one drive register data code utilized for the MSTR operation. When 4X + 2 register value is greater than 1, the value in the 4X + 3 register is the first IMPULSE Series 3 drive register data code.

The Routing Address (4X + 4) is used by the ladder logic to determine the network routing path to a device. Each IMPULSE Series 3 drive will occupy one node on the Modbus Plus network. A single Modbus Plus network can have up to 64 addressable devices (nodes). Each device must have a unique node address between 1 and 64. If more than 64 devices are to be connected, multiple networks can be joined through bridge devices. A node can be addressed across bridge devices by specifying a network routing path. The Routing 1, Routing 2, Routing 3, Routing 4, and Routing 5 (4X + 4, + 5, + 6, + 7, + 8) registers are used by the ladder logic to indicate the network routing path to a device.

The example on the following two pages illustrates the routing of IMPULSE Series 3 drives on a bridged network system. The example consists of a bridged network system diagram and routing tables with the appropriate node address assigned to routings 1 through 5.

The last routing register used must be set to '1'. This last routing register is used to specify a task number (0 to 7) to which the message is assigned. For the IMPULSE Series 3 drives on MB+ this register must be '1'.

Any unused routing registers must be set to '0'.

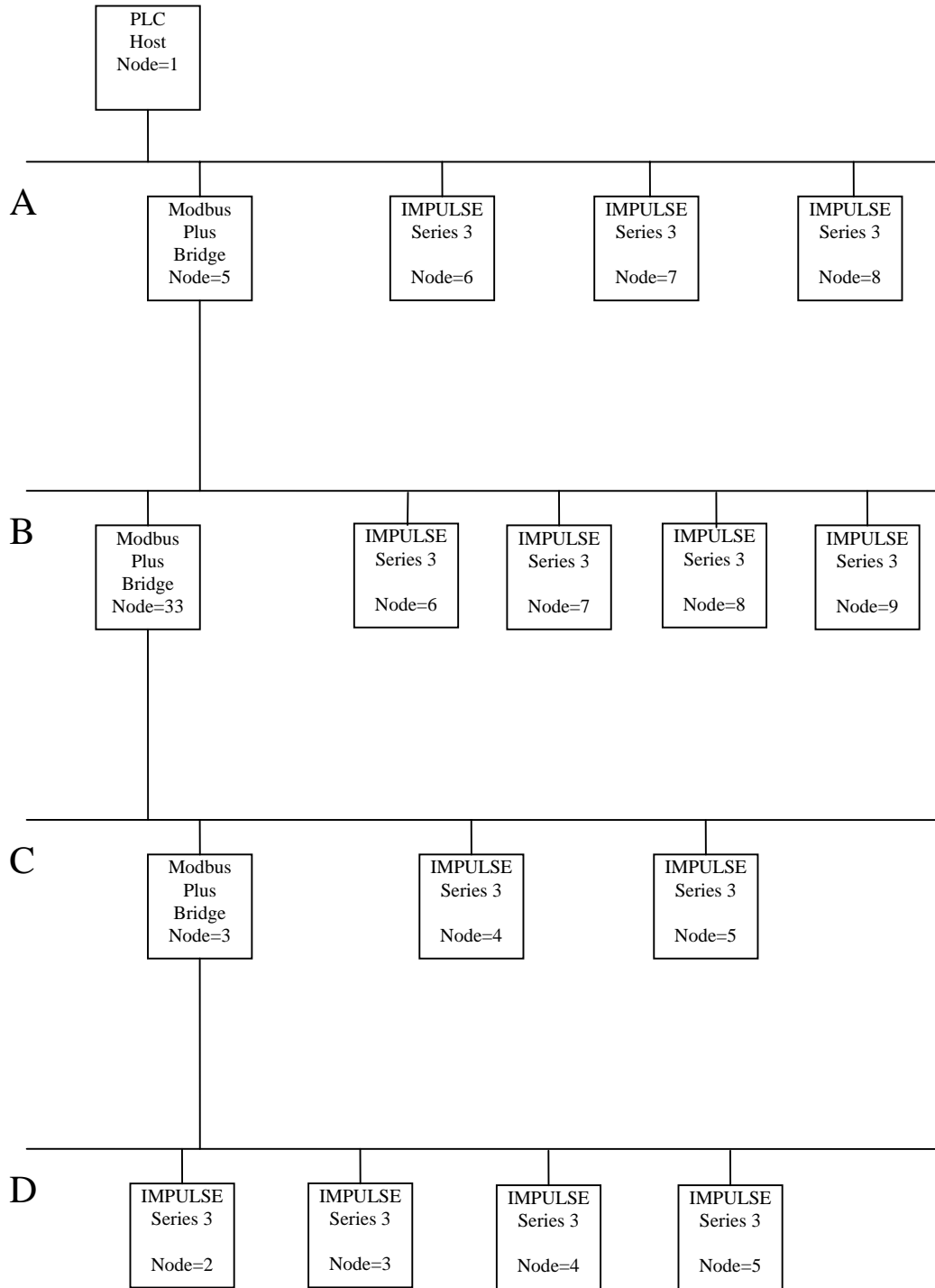

The MSTR routing path register values for the example configuration shown on the previous page are:

Network A Routing				
Register	Description	1st drive	2nd drive	3rd drive
Routing 1	Network A	6	7	8
Routing 2	Task# = 1	1	1	1
Routing 3	Not Used	0	0	0
Routing 4	Not Used	0	0	0
Routing 5	Not Used	0	0	0

Network B Routing					
Register	Description	1st drive	2nd drive	3rd drive	4th drive
Routing 1	Network A	5	5	5	5
Routing 2	Network B	6	7	8	9
Routing 3	Task # = 1	1	1	1	1
Routing 4	Not Used	0	0	0	0
Routing 5	Not Used	0	0	0	0

Network C Routing			
Register	Description	1st drive	2nd drive
Routing 1	Network A	5	5
Routing 2	Network B	33	33
Routing 3	Network C	4	5
Routing 4	Task # = 1	1	1
Routing 5	Not Used	0	0

Network D Routing					
Register	Description	1st drive	2nd drive	3rd drive	4th drive
Routing 1	Network A	5	5	5	5
Routing 2	Network B	33	33	33	33
Routing 3	Network C	3	3	3	3
Routing 4	Network D	2	3	4	5
Routing 5	Task# = 1	1	1	1	1

NOTE

The Routing 1 serves a dual purpose. The low byte of Routing 1 is used to specify the local node address. The high byte of Routing 1 is used to specify which Modbus Plus port on the PLC is to be accessed.

The routing 1 register, used to designate the address of the destination node for a network transaction. The register display is implemented logically in the 984 PLCs and physically for the Quantum PLCs:

984 PLCs

For a PLC with only one Modbus Plus port, the value of the high byte of Routing 1 should be set to zero.

If you are using a PLC with more than one MB+ port the high byte is used to indicate which port will be accessed.

For an S985-002 board in a 984 chassis mount PLC, a value of 0 in the high byte indicates that the MSTR instruction is destined for the S985 board set for PLC port #2. For a 984 PLC with built-in Modbus Plus, a value of 0 in the high byte indicates that the MSTR is destined for the on-board Modbus Plus port.

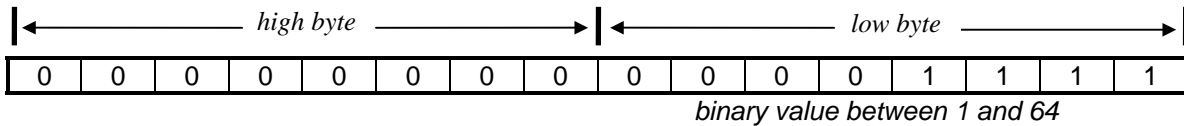

For two S985-002 boards in a 984 chassis mount PLC, a value of 1 in the high byte indicates that the MSTR instruction is destined for the second S985 board's assigned buffer space, for an S985-00 configuration in a PLC with built-in Modbus Plus, a value of 1 in the high byte indicates that the MSTR is destined for the S985 board set for comm port #2.

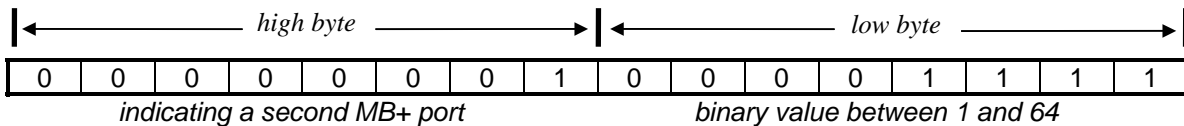

For two S985-000 boards in a 984 PLC with built-in Modbus Plus, a value of 2 in the high byte indicates that the MSTR instruction is destined for the second S985 board's assigned buffer space.

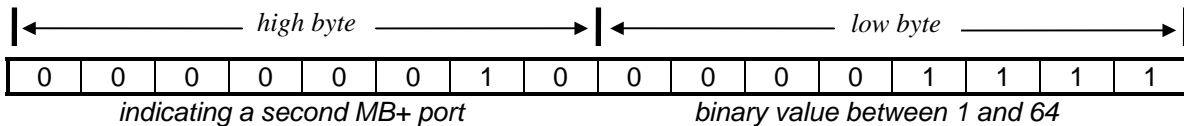

Quantum PLCs

To target a Modbus Plus Network Option Module (NOM) in a Quantum PLC backplane as the destination of an MSTR instruction, the value in the high byte represents the physical slot location of the NOM. For example, if the NOM resides in slot 7 in the back plane, the high byte of routing register 1 would look like this:

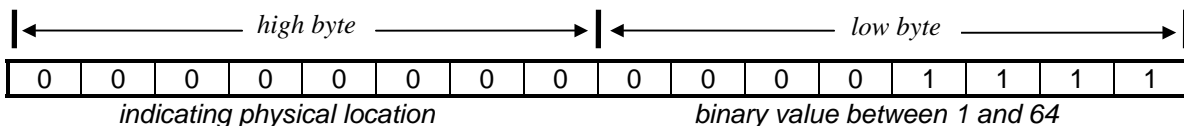

MSTR Data Block

The data entered in the middle section of the MSTR function block is the address of the first register in the Data Block. The Data Block is a sequential group of registers in the PLC. The Data Block registers are used to hold the data that will be transferred by the MSTR function block. For write operations, the Data Block is the source of the data. For read operations, the Data Block is the destination of the data.

The Data Block registers must have an address in the 4X range.

The size of the Data Block can range from 1 to 100 sequential registers.

MSTR Area Size

The data entered in the bottom section of the MSTR function block is the Area Size. The Area Size is an integer number that specifies the maximum number of registers that will be contained in the Data Block. Area Size must be a constant value ranging from 1 to 100.

The 'Number of Registers' that is stored in the Control Block register $4X + 2$ must be equal to or less than the Area Size. If this is not the case, the MSTR function will return an error.

Chapter 6

Basic MSTR Functions

- Types of Data
- Write Function
- Read Function

Types of Data

The MB+ network allows for reading and writing to a drive(s) internal data registers. IMPULSE Series 3 / Modbus Plus communication uses 16-bit holding registers. The drive's registers are divided into four functional classifications.

1. **Command Data:** These registers control the operation of the drive, and accept read/write commands from a network master device.
2. **Parameter Data:** These registers are used to configure the operation of the drive (parameter groups Ax-xx, bx-xx, Cx-xx, dx-xx, Ex-xx, Fx-xx, Hx-xx, Lx-xx, & ox-xx). They accept read/write commands from a network master device. After writing to the parameter data registers, an 'ENTER' command is required to store the data in the drive's non-volatile memory. At a minimum an 'ACCEPT' command must be issued to allow the drive to run after a parameter change.
3. **Monitor Data:** These registers are used to monitor the operation of the drive, and may only be read by a network master device.
4. **Special Data:** These are "special" Modbus Plus registers: 'ENTER' Command, 'ACCEPT' Command, Global Data, and Global Reference Multiplier.

NOTE

A listing of all the Command, Parameter, Monitor, and Special Data Codes for IMPULSE Series 3 / Modbus Plus communications can be found in the Appendix A of this manual.

Write Function

An MSTR write function (operation code = 1) will write data to one slave device on the network. When using a MB+ network, an MSTR write function can be used to send the following types of data:

- Command Data Registers
- Parameter Data Registers
- Special Data Registers

An MSTR write function may take multiple scans of the PLC ladder logic to complete. Examples of writing drive registers can be found in Chapter 9: Example #1 (write run/stop and frequency reference), Example #4 (write global run/stop and frequency reference), Example #5 (write acceleration and deceleration), Example #6 (write global frequency reference multiplier), and Example #8 (write drive parameters).

Read Function

An MSTR read function (operation code = 2) will read data from one slave device on the network. When using an MB+ network, an MSTR read function can be used to acquire the following types of data:

- Command Data Registers
- Parameter Data Registers
- Monitor Data Registers
- Special Data Registers

An MSTR read function may take multiple scans of the PLC ladder to complete. Examples of reading drive registers can be found in Chapter 9: Example #2 (read output frequency), Example #3 (read global data), Example #7 (read drive parameters), and Example #9 (read drive status registers).

Chapter 7

Special MB+ Functions

- Executing a Global Write Function
- Enabling Global Write
- Executing a Global Read Function
- Using the 'ACCEPT' and 'ENTER' Commands
- Writing to the Global Frequency Reference Multiplier
- Origin of RUN/STOP and Frequency Reference Commands
- Using the IMPULSE Series 3 Drive Register 001h

Executing a Global Write Function

An MSTR global write function (operation code = 5) will write data to all slave devices on the network. The global write function allows all slave devices on the MB+ network to receive the data at the same time. When using a MB+ network, an MSTR write function can provide two or three Data Area Registers.

The first word of global data written to drive is used by the drive to select the commands being sent to it.

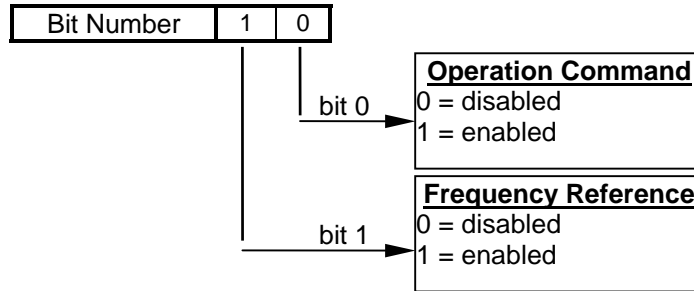

The following data are considered the three possible cases for Global Write Data:

Case 1: Using Operation Command and Frequency Reference

MSTR Function Data Area (Register Offset)	Function	IMPULSE Series 3 Drive Register Data Code
$4X + 0$	3	selecting both operation command and frequency reference
$4X + 1$	operation command	drive register (001h)
$4X + 2$	frequency reference	drive register (002h)

Case 2: Using Operation Command

MSTR Function Data Area (Register Offset)	Function	IMPULSE Series 3 Drive Register Data Code
$4X + 0$	1	selecting the operation command
$4X + 1$	operation command	drive register (001h)

Case 3: Using Frequency Reference

MSTR Function Data Area (Register Offset)	Function	IMPULSE Series 3 Drive Register Data Code
$4X + 0$	2	selecting the frequency reference
$4X + 1$	frequency reference	drive register (002h)

See Appendix A for additional information on data registers 001h and 002h.

An MSTR global write function will take one scan of the PLC ladder logic to complete. An example of globally writing drive registers can be found in Chapter 9: Example #4 (write global run/stop and frequency reference).

Enabling Global Write

Each drive that will receive global write data must be initialized to do so. If a drive is not initialized to receive global write data, it will ignore any global data that is transmitted on the MB+ network.

The data held in the Modbus Plus special data register F200h indicates the Modbus Plus node address of the device (PLC) that will be sending the global data to the drive. The IMPULSE Series 3 drive will only accept global data that is sent from this device. To enable global data, write the Modbus Plus node address (1-64) of the device sending global data to register F200h. To disable global data, write a '0' to register F200h.

An example of enabling global data can be found in Chapter 9: Example #4 (write global run/stop and frequency reference).

Executing a Global Read Function

An MSTR global read function (operation code = 6) will read eight specific status registers. The global read function must be enabled by turning Dip switch SW1-8 ON. The status data can be read by any PLC connected to a local MB+ network.

The following registers are considered the "Global Read Data":

MSTR Function Data Area	Function	IMPULSE Series 3 Drive Register Data Code
4X + 0	Operation Command	001h
4X + 1	Output Frequency	F005h
4X + 2	Output Current	F006h
4X + 3	DC Bus Voltage	F008h
4X + 4	Drive Status	F000h
4X + 5	Existing Fault Code 1	F009h
4X + 6	Existing Fault Code 2	F00Ah
4X + 7	Existing Fault Code 3	F00Bh

See Appendix A for more details on these Data Registers. An example of reading global registers is shown in Chapter 9: Example #3 (Read Global Registers).

Using the 'ACCEPT' and 'ENTER' Commands

The IMPULSE Series 3 has two types of memory: 'Volatile' and 'Non-Volatile'. Data held in Volatile memory will be lost when power is removed from the drive. Data held in Non-Volatile memory will be retained when power is removed from the drive. The IMPULSE Series 3 also has 'active' and 'inactive' areas of memory. The different registers are saved and activated differently, as described below.

Command Registers:

The command registers (001h - 00Fh) are stored in Volatile Memory. When writing to a command register the new data becomes active immediately. In the case of a power loss, all data stored in these registers will not be retained.

Parameter Registers:

The parameter registers (100h-125h, 18Dh-1A5h, 200h-240h, 280h-296h, 300h-316h, 380h-39Ch, 400h-420h, 480h-4AAh, and 500-50Dh) are stored in Non-Volatile Memory. When writing new data to parameter registers, the new data is not active.

Sending the 'ACCEPT' command will cause the new data to become active.

The 'ACCEPT' command is accomplished by writing a value of '0' to data code FFDDh.

The 'ACCEPT' command allows the drive to run with these changed parameters. It also allows parameters to again be changed from the drive keypad. The data is not saved to Non-Volatile Memory.

Sending the 'ENTER' command will cause the new data to become active AND to be saved in Non-Volatile memory.

The 'ENTER' command is accomplished by writing a value of '0' to data code FFFDh.

If a power loss occurs after the new data has been saved (by using the 'ENTER' command) into Non-Volatile Memory, the data will be retained.

Monitor Registers:

The monitor registers (020h - 097h, F000h - F00Fh, and F100h - F10Ah) are stored in Volatile Memory. These registers cannot be written to (read only registers). Any data read from the monitor registers will not be retained during a power loss situation.

Special Registers:

The special registers (F200h, F201h, FFDDh, and FFFDh) are in Volatile Memory. These registers will not be retained during a power loss situation. When writing to a special register, the new data becomes active immediately.

Examples of writing the 'ENTER' and 'ACCEPT' command can be found in Chapter 9: Example #5 (Write Acceleration and Deceleration), and Example #8 (Write Drive Parameter Registers).



CAUTION

USE THE 'ENTER' COMMAND ONLY WHEN NECESSARY!

The life of the Non-Volatile EEPROM on the IMPULSE Series 3 will support a finite number of operations. This means that the 'ENTER' command can only be used a maximum of 100,000 times to store data in the EEPROM. After the specified number of operations, the EEPROM may fault (ERR), requiring the IMPULSE Series 3 control board to be replaced.

Writing to the Global Frequency Reference Multiplier

In some applications, it will be necessary to change the frequency of multiple drives at the same time. The global write function can easily be used to write a single value for frequency reference to all of the drives connected on the MB+ network. In this way, all the selected drives can receive the same frequency reference value at the same time.

System or process applications may require each drive to run at a different output frequency while changing speed simultaneously with other drives. For systems that require this feature, the Global Frequency Reference Multiplier can be used.

IMPULSE Series 3 Register F201h is the Global Frequency Reference Multiplier register. The power-up default value of this register is '1.000'.

To make use of the Global Frequency Reference Multiplier, IMPULSE Series 3 register F200h must be setup to enable global data.

When global data is properly initialized, the value written to IMPULSE Series 3 Register 002h (frequency reference) will be multiplied by the value of IMPULSE Series 3 Register F201h (global frequency reference multiplier) to produce the frequency reference value. This will allow each drive on the network to scale the global frequency reference that it receives.

The diagram below shows a global frequency reference value of 30.00 Hz being written to 3 drives. Each drive has a different Global Frequency Reference Multiplier value.

An example of using the Global Frequency Reference Multiplier can be found in Chapter 9: Example #6 (global frequency multiplier).

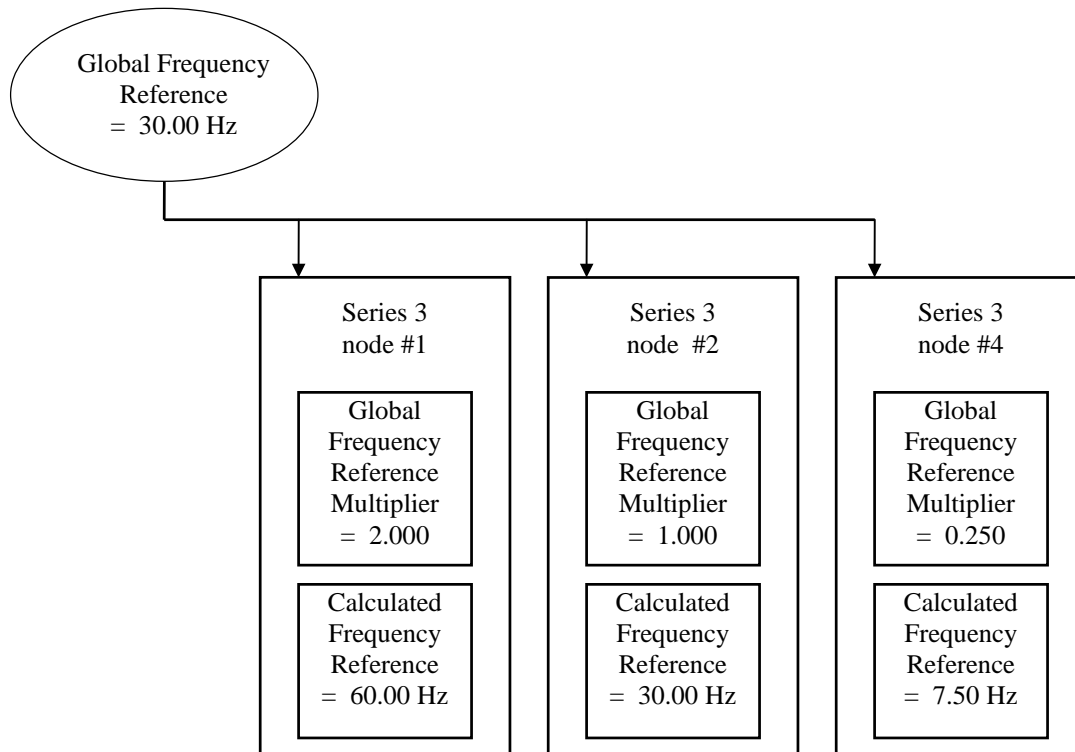

Origin of RUN/STOP and Frequency Reference Commands

The drive can be configured to receive operation signals (Run, Stop, Forward, Reverse, ...) from the MB+ network, serial communication, the external drive terminals, or the Digital Operator. IMPULSE Series 3 Drive Register b3-02 (18Eh) is used to setup the source of the operation signals. The following table indicates the possible configurations for the origin of the operation signals:

RUN / STOP	
b3-02	Commands from:
0	Digital Operator
1	Terminal
2	Serial Communication
3	Option PCB (MB+ board)

The drive can be configured to receive a frequency reference from the MB+ network, serial communication, the external drive terminals, or the Digital Operator. IMPULSE Series 3 Drive Register b3-01 (18Dh) is used to setup the source of the frequency reference. The following table indicates the possible configurations for the origin of the frequency reference:

FREQUENCY REFERENCE	
b3-01	Commands from:
0	Digital Operator
1	Terminal
2	Serial Communication
3	Option PCB (MB+ board)
4 (H6-01)	Pulse Input

The value of IMPULSE Series 3 Drive Register b3-01 (18Dh) and b3-02 (18Eh) may be stored in Non-Volatile RAM memory on the drive by use of the 'ENTER' command. After the value has been 'entered', that value will be retained if the drive unit is powered down.

Using IMPULSE Series 3 Drive Register 001h

When the drive is setup to receive Operation Signals from the MB+ Network, IMPULSE Series 3 Drive Register 001h is used to operate the drive. This register performs multiple functions. Each of the first 10 bits of this register serves a different purpose. The remaining bits of this register are not used. The following diagram shows the function of each of the bits of this register. Bit 0 is the least significant bit of the register. Bit 15 is the most significant bit of the register.

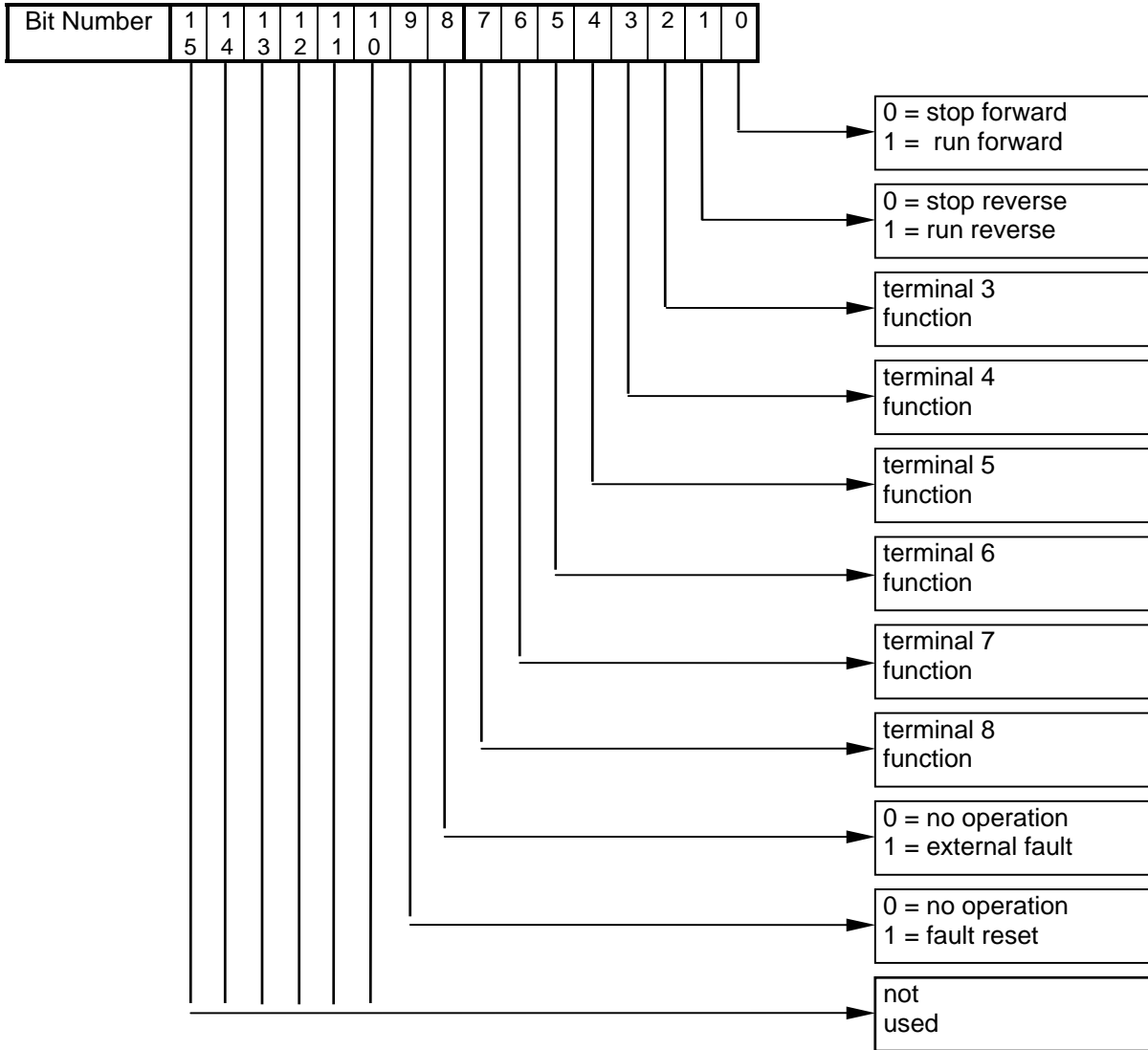

Bit 0 is used to start and stop the forward operation of the drive. To command the drive to stop forward, this bit should be set to a '0'. To command the drive to run forward, this bit should be set to a '1'.

Bit 1 is used to start and stop the reverse operation of the drive. To command the drive to stop reverse, this bit should be set to a '0'. To command the drive to run reverse, this bit should be set to a '1'.

Bit 2 is used to select the function for terminal 3. The function for terminal 3 is determined by the setting of parameter H1-01.

Bit 3 is used to select the function for terminal 4. The function for terminal 4 is determined by the setting of parameter H1-02.

Bit 4 is used to select the function for terminal 5. The function for terminal 5 is determined by the setting of parameter H1-03.

Bit 5 is used to select the function for terminal 6. The function for terminal 6 is determined by the setting of parameter H1-04.

Bit 6 is used to select the function for terminal 7. The function for terminal 7 is determined by the setting of parameter H1-05.

Bit 7 is used to select the function for terminal 8. The function for terminal 8 is determined by the setting of parameter H1-06.

Bit 8 is used to cause an external fault. To cause an external fault, this bit should be set to a '1'.

Bit 9 is used to reset drive faults that have occurred. To allow the drive to run, this bit should be set to a '0'. To reset a drive fault, this bit should be momentarily set to a '1'. To reset a fault, the run/stop bits (Bit 0 and Bit 1) must also be a '0'.

Chapter 8

Diagnostics and Troubleshooting

- Troubleshooting Information
- Diagnostic LED (D2)
- MSTR Error Codes
- IMPULSE Series 3 Failure Codes

Troubleshooting Information

If the "Cable Loss" is enabled and a situation causing a cable loss occurs, the drive will generate a cable loss fault. This fault will be displayed on the Digital Operator as ' **EF0 - External Flt** '. This ' **EF0** ' fault can be cleared by pressing the RESET key on the keypad, only if the cable loss condition no longer exists.

Diagnostic LED (D2)

The green diagnostic LED on the MB+ board is not visible with the drive cover in place. This LED's output is controlled by the on-board peer processor and displays node status by flashing repetitive patterns. The following is a listing of the LED flashing patterns, and an explanation of each.

STATUS				
Blink Pattern		Timing		Status
Green	Continuous Slow Blinks	ON OFF	340 msec 640 msec	This node is off-line and is not allowed to transmit data across the link. It does hear all other active nodes on the link, and builds an active node table.
Green	Continuous Rapid Blinks	ON OFF	80 msec 80 msec	This Modbus Plus node is operating normally. It is successfully receiving and passing the token.
Green	Two Rapid Blinks	ON OFF	160 msec 160 msec	This MB+ node is permanently in the idle state. It is monitoring other nodes on the Modbus Plus link pass the token, but the token is never passed to this node. This node may have a bad transmitter.
Green	Three Rapid Blinks	ON OFF	160 msec 160 msec	This Modbus Plus node is not finding any other nodes on the Modbus Plus link. It is claiming and winning the token, but has no other node to pass it to. This node can periodically disrupt communication on the link. This condition can indicate a problem with the communication wiring.
Green	Four Rapid Blinks	ON OFF	160 msec 160 msec	This Modbus Plus node has found another node on the Modbus Plus link, which has an identical node address. This node will remain off-line, monitoring the Modbus Plus link until the duplicate node is not heard from for 5 seconds.

MSTR Error Codes

If an error occurs during an MSTR operation, a hexadecimal error code will be displayed in the second register of the control block (the top section). The form of the code is Mmss, where:

- **M** represents the major code
- **m** represents the minor code
- **ss** represents a subcode

A list of error codes appears in the following table.

Error Code (Hex)	DEFINITION	
1001	User-initiated abort	
2001	Invalid operation type	
2002	User parameter changed	
2003	Invalid length	
2004	Invalid offset	
2005	Invalid length + offset	
2006	Invalid slave device data area	
2007	Invalid slave device network area	
2008	Invalid slave device network routing	
2009	Route equal to your own address	
200A	Attempting to obtain more global data words than available	
30ss	Modbus slave exception response	
	ss	DEFINITION
	01	Slave device does not support the requested operation
	02	Nonexistent slave device registers requested
	03	Invalid data value requested
	04	<i>Unassigned</i>
	05	Slave has accepted long-duration program command
	06	Function cannot be performed - a long duration command is in effect
	08-FF	<i>Unassigned</i>
4001	Inconsistent Modbus slave response	
5001	Inconsistent network response	
6mss	Routing failure	
	m	DEFINITION
	0 or 1	Routing register 1 (local network)
	2	Routing register 2
	3	Routing register 3
	4	Routing register 4
	5	Routing register 5
	ss	DEFINITION
	01	No response received
	02	Program access denied
	03	Node off-line and unable to communicate
	04	Exception response received
	05	Router node data paths busy
	06	Slave device down
	07	Bad destination address
	08	Invalid node type in routing path
	10	Slave has rejected the command
	20	Initiated transaction forgotten by slave device
	40	Unexpected master output path received
80	Unexpected response received	

IIMPULSE Series 3 Failure Codes

The IMPULSE Series 3 drive can have a drive failure, such as undervoltage, overload, external fault, etc. When a drive failure occurs, it can be classified as an alarm, a minor fault, or a major fault. The drive reacts differently with each type of failure. An alarm displays a warning indication, however operation continues. Minor faults allow continued operation, and a contact will close only if one of the multi-function outputs is set up as a minor fault contact. The major faults cause the motor to coast to stop, and the fault signal output is present at terminals MA, MB and MC.

The IMPULSE Series 3's parameters U2-01 (current fault), U2-02 (last fault), and U3-01 (most recent) display a fault code representing the drive failure. Using the U2-xx and U3-xx registers can aid greatly in troubleshooting the IMPULSE Series 3.

The following table indicates the abbreviation displayed on the Digital Operator and the hexadecimal code viewed in drive parameters: U2-01, U2-02, and U3-01 when a specific drive failure occurs. The table also indicates whether the drive failure is an A-alarm, m-minor fault, or M-major fault.

Drive Fault	Digital Operator Display	Hexadecimal Code	Alarm, minor fault, or Major Fault
DC Bus Fuse Open	PUF	1	M
DC Bus Undervoltage	UV1	2	A
CTL PS Undervoltage	UV2	3	A
MC Answerback	UV3	4	A
Short Circuit	SC	5	M
Ground Fault	GF	6	M
Overcurrent	oC	7	M
Overvoltage	oV	8	M
Heatsink Overtemperature	oH	9	M
Drive Overheat	oH1	A	M
Motor Overload	oL1	B	M
Drive Overload	oL2	C	M
Overtorque 1	oL3	D	M
Overtorque 2	oL4	E	M
Dynamic Braking Transistor	RR	F	M
Dynamic Braking Resistor	RH	10	M
External Fault 3	EF3	11	M
External Fault 4	EF4	12	M
External Fault 5	EF5	13	M
External Fault 6	EF6	14	M
External Fault 7	EF7	15	M
External Fault 8	EF8	16	M
Fan Fault	FAN	17	M
Overspeed	oS	18	M
Speed Deviation	DEV	19	M
PG Open	PGo	1A	M
Input Phase Loss	PF	1B	M
Output Phase Loss	LF	1C	M
DCCT Fault	CF	1D	M
Operator Disconnected	OPR	1E	M
EEPROM R/W Error	ERR	1F	M
reserved		20	-
Modbus Com Error	CE	21	M
Communication Option Card	OPBUS	22	M
Serial Communication Error	E15	23	M
Option CPU Down	E10	24	M
Control Fault	CPFxx	25	M
Zero Servo Fault	SVE	26	-
Noisy Encoder Fault	SVR	27	M
Snap Shaft Fault	SNAP	28	M

Load Check Err	LCI	29	M
Brake Welded	BE7	2A	M
PG Open During Load Float	PGO2	2B	M
PG Compare Failed	PROX	2C	M
Out of Sync	SYNC	2D	M
DDS External Fault	EF0	2E	M
Reserved	-	2F-82	-
Base Block Circuit Fault	CPF02	83	M
EEPROM Fault	CPF03	84	M
Internal A/D Converter Fault	CPF04	85	M
External A/D Converter Fault	CPF05	86	M
Option Card Fault	CPF06	87	M
Reserved	-	88-90	M
Control Circuit Fault 20	CPF20	91	M
Control Circuit Fault 21	CPF21	92	M
Control Circuit Fault 22	CPF22	93	M
Control Circuit Fault 23	CPF23	94	M

Note: Further detail on drive failures and troubleshooting can be found in Section 6 of the IMPULSE Series 3 technical manual.

Chapter 9

Examples

- Example #1 Write RUN/STOP and Frequency Reference
- Example #2 Read Output Frequency
- Example #3 Read Global Data
- Example #4 Write Global RUN/STOP and Frequency Reference
- Example #5 Write Acceleration and Deceleration Times
- Example #6 Write a Global Frequency Reference Multiplier
- Example #7 Read Drive Parameters
- Example #8 Write Drive Parameters
- Example #9 Read Drive Status Registers

Examples

In the following examples, a Modicon PLC and three IMPULSE Series 3 variable frequency drives are connected via a MB+ network that is configured as follows:

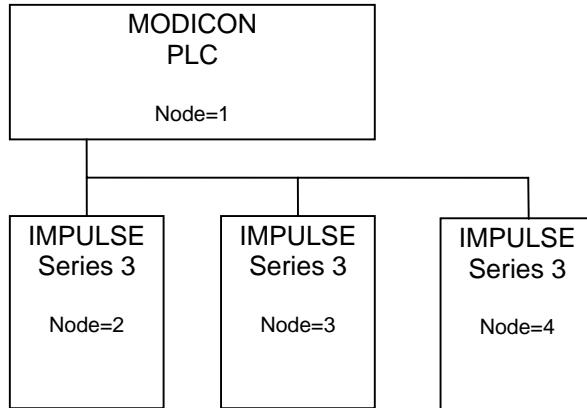

Example #1

Write RUN/STOP and Frequency Reference to a Drive

This example will show how to write a RUN FORWARD command and a 60.00 Hz frequency reference to a drive. This example assumes that the drive is located at node 3.

In this example, an input to the PLC will be used to initiate the MSTR that will write the 'Operation Command' and 'Frequency Reference'. This input will be addressed at 10001.

Since the 'Operation Command' register (001h) and the 'Frequency Reference' register (002h) are consecutive registers, one MSTR function can be used to write to both registers.

In this example, the MSTR control registers will start at register 40010. The MSTR data registers will start at register 40020. There will be 2 MSTR data registers. The MSTR function inserted into the ladder logic would look like:

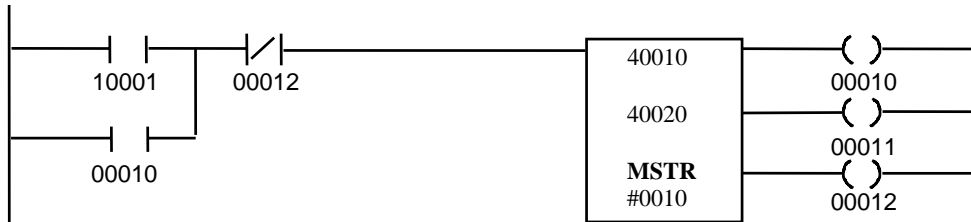

The Control Block registers must be loaded with the following data before the MSTR block is executed:

CONTROL BLOCK			
Register Number	Register Description	Register Data	Data Description
40010	Operation Code	0001h	0001h = Write to Multiple Registers
40011	Network Error Code	0000h	The error code returned by Modbus Plus communications
40012	Number of Registers	0002h	Write to 2 consecutive registers
40013	Register Data Code	0001h	Data code for run/stop command
40014	Routing 1	0003h	Modbus Plus node address of drive = 0003h
40015	Routing 2	0001h	End of routing path = 0001h (Modbus Plus requirement)
40016	Routing 3	0000h	This routing register is not used, must be set to 0
40017	Routing 4	0000h	This routing register is not used, must be set to 0
40018	Routing 5	0000h	This routing register is not used, must be set to 0

The Data Block registers must be loaded with the appropriate RUN/STOP and Frequency Reference data before the MSTR block is executed.

DATA BLOCK			
Register Number	Register Description	Register Data	Data Description
40020	Operation Signals	0001h	Run Forward = bit 0/on = 0001h
40021	Freq. Reference	1770h	60.00 Hz = 6000 (decimal) = 1770h

Example #2 Read Output Frequency from Drive #3

This example will show how to read the output frequency of an IMPULSE Series 3 drive on the MB+ network.

In this example, an input to the PLC will be used to initiate the MSTR that will read the output frequency. This input will be addressed at 10002.

The Output Frequency is held in the register with data code F005h.

In this example, the MSTR control registers will start at register 40030. The MSTR data register will start at register 40039. There will be 1 MSTR data register. The MSTR function inserted into the ladder logic would look like:

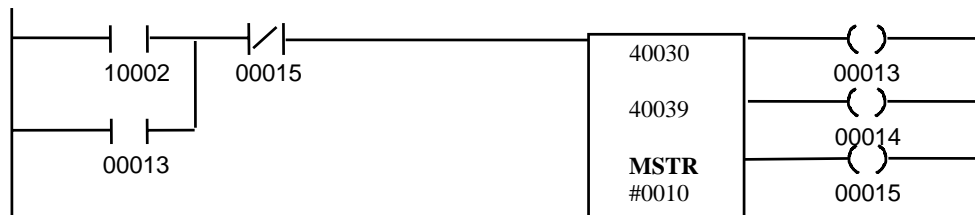

The Control Block registers must be loaded with the following data before the MSTR block is executed:

CONTROL BLOCK			
Register Number	Register Description	Register Data	Data Description
40030	Operation Code	0002h	0002h = Read from Multiple Registers
40031	Network Error Code	0000h	The error code returned by Modbus Plus communications
40032	Number of Registers	0001h	Read from 1 consecutive register
40033	Register Data Code	F005h	Data code for output frequency command
40034	Routing 1	0003h	Modbus Plus node address of drive = 0003h
40035	Routing 2	0001h	End of routing path = 0001h (Modbus Plus requirement)
40036	Routing 3	0000h	This routing register is not used, must be set to 0
40037	Routing 4	0000h	This routing register is not used, must be set to 0
40038	Routing 5	0000h	This routing register is not used, must be set to 0

The Data Block register will be filled by the PLC with the Drive #3 Output Frequency data after the MSTR block has been executed.

DATA BLOCK			
Register Number	Register Description	Register Data	Data Description
40039	Freq. Reference	READ	60.00 Hz = 6000 (decimal) = 1770h

Example #3 Read Global Data from Drives #2 and #3

This example will read global data from drive #2 and drive #3. To enable a global read, Dip switch SW1-8 must be turned ON for each drive. The MB+ interface provides eight specific registers that can be read by the PLC. This is done via the "Read Global Data" MSTR Function (operation code #6). The PLC can only read global data from one drive at a time; therefore multiple MSTR transactions will be required.

In this example, an input to the PLC will be used to initiate the MSTRs that will read the global data. This input will be addressed at 10003.

This example requires multiple MSTR transactions. The following MSTR transactions will be performed:

#	MSTR Transaction	Control Registers	Data Registers
1	Read global data from drive #2	40040	40050
2	Read global data from drive #3	40060	40070

The MSTR functions inserted into the ladder logic would look like:

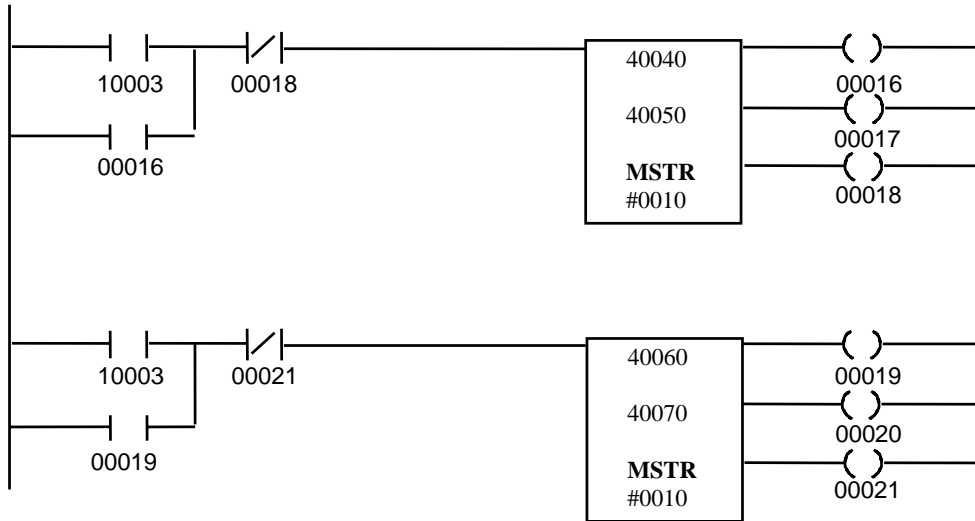

MSTR Transaction #1

In this example, the MSTR blocks are executed simultaneously. The Control Block and Data Block registers for the first MSTR must be loaded with the following data before the MSTR block is executed. This MSTR transaction reads global data from drive #2.

CONTROL BLOCK			
Register Number	Register Description	Register Data	Data Description
40040	Operation Code	0006h	0006h = Read Global Data MSTR Function
40041	Network Error Code	0000h	The error code returned by Modbus Plus communications.
40042	Number of Registers	0008h	Number of words of global data requested (0-8).
40043	Available Words	0000h	The number of words available from the requested node. This value is updated for you.
40044	Routing 1	0002h	Modbus Plus node address of the drive = 0002h
40045	Routing 2	0001h	End of routing path = 0001h (Modbus Plus requirement)
40046	Routing 3	0000h	This routing register is not used, must be set to 0
40047	Routing 4	0000h	This routing register is not used, must be set to 0
40048	Routing 5	0000h	This routing register is not used, must be set to 0

DATA BLOCK			
Register Number	Register Description	Register Data	Data Description
40050	Operation Command	READ	receives the drive's operation command (001h).
40051	Output Frequency	READ	receives the drive's output frequency (F005h).
40052	Output Current	READ	receives the drive's output current (F006h).
40053	Dc Bus Voltage	READ	receives the voltage (F008h).
40054	Drive Status	READ	receives the drive status (F000h).
40055	Existing Fault Code 1	READ	receivess the drive existing fault data (F009h)
40056	Existing Fault Code 2	READ	receivess the drive existing fault data (F00Ah)
40057	Existing Fault Code 3	READ	receivess the drive existing fault data (F00Bh)

MSTR Transaction #2

The Control Block and Data Block registers for the second MSTR must be loaded with the following data before the MSTR block is executed. This MSTR transaction reads global data from drive #3.

CONTROL BLOCK			
Register Number	Register Description	Register Data	Data Description
40060	Operation Code	0006h	0006h = Read Global Data MSTR Function
40061	Network Error Code	0000h	The error code returned by Modbus Plus communications.
40062	Number of Registers	0008h	Number of words of global data requested (0-8).
40063	Available Words	0000h	The number of words available from the requested node. This value is updated for you.
40064	Routing 1	0003h	Modbus Plus node address of the drive = 0003h
40065	Routing 2	0001h	End of routing path = 0001h (Modbus Plus requirement)
40066	Routing 3	0000h	This routing register is not used, must be set to 0
40067	Routing 4	0000h	This routing register is not used, must be set to 0
40068	Routing 5	0000h	This routing register is not used, must be set to 0

DATA BLOCK			
Register Number	Register Description	Register Data	Data Description
40070	Operation Command	READ	receives the drive's operation command (001h).
40071	Output Frequency	READ	receives the drive's output frequency (F005h).
40072	Output Current	READ	receives the drive's output current (F006h).
40073	DC Bus Voltage	READ	receives the voltage (F008h).
40074	Drive Status	READ	receives the drive status (F000h).
40075	Existing Fault Code 1	READ	receivess the drive existing fault data (F009h)
40076	Existing Fault Code 2	READ	receivess the drive existing fault data (F00Ah)
40077	Existing Fault Code 3	READ	receivess the drive existing fault data (F00Bh)

Example #4 Write Global RUN/STOP and Frequency Reference

This example will show how to write a global RUN REVERSE command and a 34.56 Hz frequency reference to all drives on the MB+ network. To enable this global write function, the address of the active local network PLC/host device (the source of global data) must be written to data register code F200h for each drive receiving global data.

In this example, an input to the PLC will be used to initiate the MSTRs that will write to the F200h register. This input will be 10004.

This example requires multiple MSTR transactions. The following MSTR transactions will be performed:

#	MSTR Transaction	Control Registers	Data Registers
1	Enable Global Data to the drive at node #2	40100	40110
2	Enable Global Data to the drive at node #3	40120	40130
3	Enable Global Data to the drive at node #4	40140	40150
4	Write Global Data to the drives	40160	40170

The MSTR functions inserted into the ladder logic would look like:

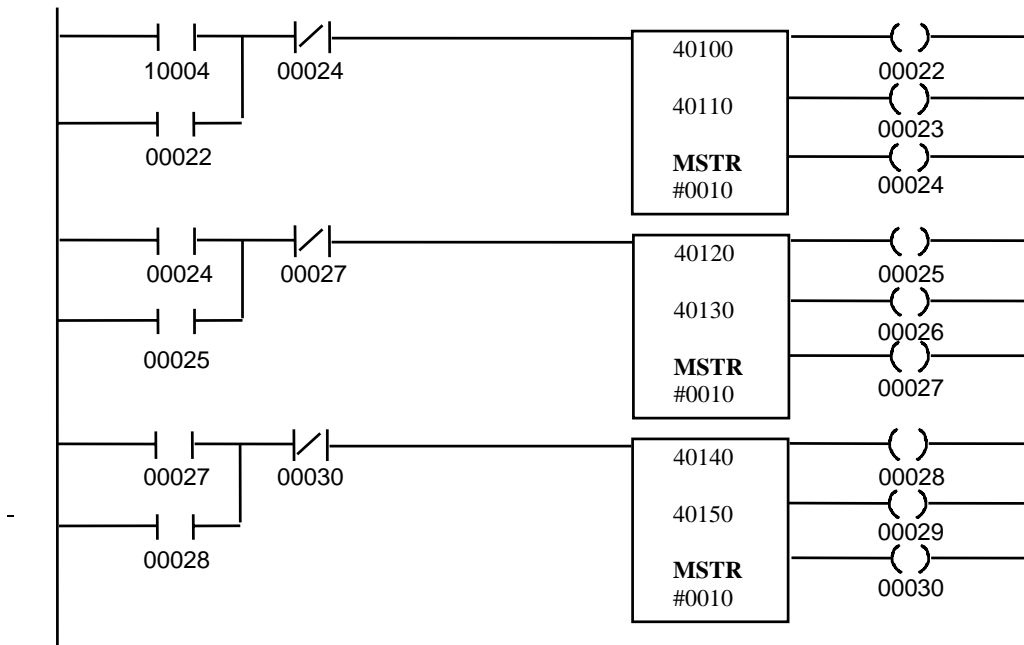

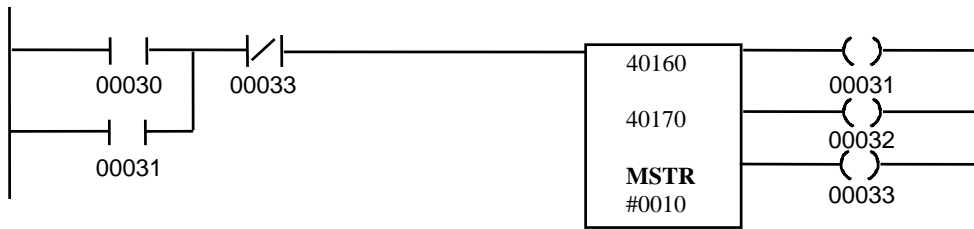

MSTR Transaction #1

This MSTR transaction writes to the F200h register of the drive on node #2. The Control Block registers must be loaded with the following data before the MSTR block is executed:

CONTROL BLOCK			
Register Number	Register Description	Register Data	Data Description
40100	Operation Code	0001h	0001h = Write to Multiple Registers
40101	Network Error Code	0000h	The error code returned by Modbus Plus communications
40102	Number of Registers	0001h	Write to 1 register
40103	Data Register Code	F200h	Global Write Data Code
40104	Routing 1	0002h	Modbus Plus node address of drive = 0002h
40105	Routing 2	0001h	End of routing path = 0001h (Modbus Plus requirement)
40106	Routing 3	0000h	This routing register is not used, must be set to 0
40107	Routing 4	0000h	This routing register is not used, must be set to 0
40108	Routing 5	0000h	This routing register is not used, must be set to 0

The Data Block registers must be loaded with the appropriate PLC address before the MSTR block is executed.

DATA BLOCK			
Register Number	Register Description	Register Data	Data Description
40110	Receive Global Data	0001h	0001h = the PLC/host device (source of global data) address.

MSTR Transaction #2

This MSTR transaction writes to the F200h register of the drive on node #3. The Control Block registers must be loaded with the following data before the MSTR block is executed:

CONTROL BLOCK			
Register Number	Register Description	Register Data	Data Description
40120	Operation Code	0001h	0001h = Write to Multiple Registers
40121	Network Error Code	0000h	The error code returned by Modbus Plus communications
40122	Number of Registers	0001h	Write to 1 register
40123	Data Register Code	F200h	Global Write Data Code
40124	Routing 1	0003h	Modbus Plus node address of drive = 0003h
40125	Routing 2	0001h	End of routing path = 0001h (Modbus Plus requirement)
40126	Routing 3	0000h	This routing register is not used, must be set to 0
40127	Routing 4	0000h	This routing register is not used, must be set to 0
40128	Routing 5	0000h	This routing register is not used, must be set to 0

The Data Block registers must be loaded with the appropriate PLC address before the MSTR block is executed.

DATA BLOCK			
Register Number	Register Description	Register Data	Data Description
40130	Receive Global Data	0001h	0001h = the PLC/host device (source of global data) address.

MSTR Transaction #3

This MSTR transaction writes to the F200h register of the drive on node #4. The Control Block registers must be loaded with the following data before the MSTR block is executed:

CONTROL BLOCK			
Register Number	Register Description	Register Data	Data Description
40140	Operation Code	0001h	0001h = Write to Multiple Registers
40141	Network Error Code	0000h	The error code returned by Modbus Plus communications
40142	Number of Registers	0001h	Write to 1 register
40143	Data Register Code	F200h	Global Write Data Code
40144	Routing 1	0004h	Modbus Plus node address of drive = 0004h
40145	Routing 2	0001h	End of routing path = 0001h (Modbus Plus requirement)
40146	Routing 3	0000h	This routing register is not used, must be set to 0
40147	Routing 4	0000h	This routing register is not used, must be set to 0
40148	Routing 5	0000h	This routing register is not used, must be set to 0

The Data Block registers must be loaded with the appropriate PLC address before the MSTR block is executed.

DATA BLOCK			
Register Number	Register Description	Register Data	Data Description
40150	Receive Global Data	0001h	0001h = the PLC/host device (source of global data) address.

MSTR Transaction #4

This MSTR transaction writes the global data to all drives that have enabled global data. The Control Block registers must be loaded with the following data before the MSTR function is executed.

CONTROL BLOCK			
Register Number	Register Description	Register Data	Data Description
40160	Operation Code	0005h	0005h = Global Write
40161	Network Error Code	0000h	The error code returned by Modbus Plus communications
40162	Number of Registers	0003h	Write to 3 consecutive registers
40163	Data Register Code	XXXX	This register is not used when writing global data
40164	Routing 1	XXXX	This register is not used when writing global data
40165	Routing 2	XXXX	This register is not used when writing global data
40166	Routing 3	XXXX	This register is not used when writing global data
40167	Routing 4	XXXX	This register is not used when writing global data
40168	Routing 5	XXXX	This register is not used when writing global data

The Data Block registers must be loaded with the appropriate Global RUN/STOP and Frequency Reference data before the MSTR block is executed.

DATA BLOCK			
Register Number	Register Description	Register Data	Data Description
40170	Activation Bit Map Register	0003h	bit 0/on = Operation Signals activated bit 1/on = Frequency Reference activated
40171	Operation Signals	0002h	Run Reverse = bit 0/off, bit 1/on = 0002h
40172	Freq. Reference	0D80h	34.56 Hz = 3456 (decimal) = 0D80h

Example #5

Write Acceleration and Deceleration Times (B5-01 and B5-02) to a Drive

This example will show how to write acceleration time 1 and deceleration time 1 to a drive on the MB+ network. After writing the new acceleration and deceleration times, the new data will be stored in Non-Volatile memory with the 'ENTER' command.

In this example, an input to the PLC will be used to initiate the MSTRs that will write the acceleration and deceleration times. This input will be addressed at 10005.

This example requires multiple MSTR transactions. The following MSTR transactions will be performed:

#	MSTR Transaction	Control Registers	Data Registers
1	Write Accel and Decel registers	40180	40190
2	Write the ENTER command	40200	40210

The MSTR functions inserted into the ladder logic would look like:

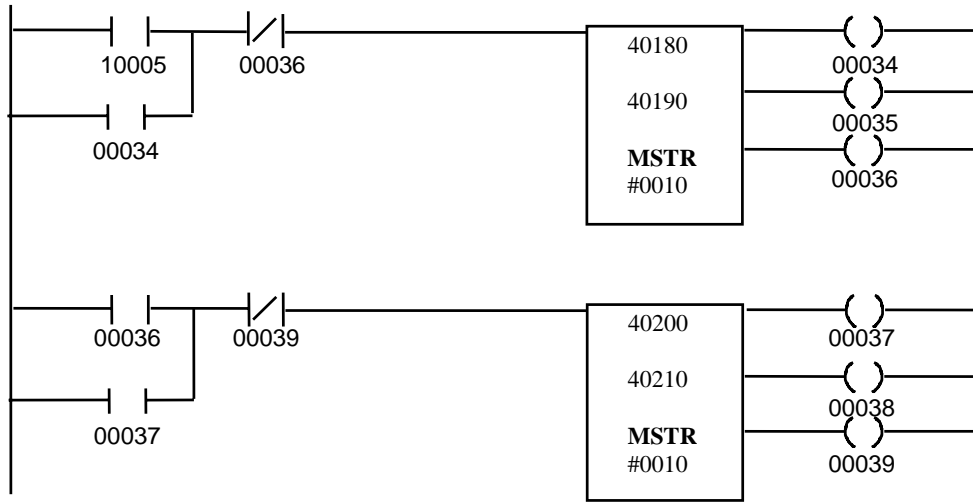

MSTR Transaction #1

In this example, the MSTR blocks are executed sequentially. The Control Block and Data Block registers for the first MSTR must be loaded with the following data before the MSTR block is executed. This MSTR writes to the Acceleration Time 1 register (B5-01) and the Deceleration Time 1 register (B5-02) to drive (at node 2).

CONTROL BLOCK			
Register Number	Register Description	Register Data	Data Description
40180	Operation Code	0001h	0001h = Write to Multiple Registers
40181	Network Error Code	0000h	The error code returned by Modbus Plus communications
40182	Number of Registers	0002h	Write to 2 consecutive registers
40183	Data Register Code	0196h	B5-01 data code
40184	Routing 1	0002h	Modbus Plus node address of drive = 0002h
40185	Routing 2	0001h	End of routing path = 0001h (Modbus Plus requirement)
40186	Routing 3	0000h	This routing register is not used, must be set to 0
40187	Routing 4	0000h	This routing register is not used, must be set to 0
40188	Routing 5	0000h	This routing register is not used, must be set to 0

DATA BLOCK			
Register Number	Register Description	Register Data	Data Description
40190	Acceleration Time 1	001Eh	3.0 sec = 10 (decimal) = 000Ah
40191	Deceleration Time 1	0014h	2.0 sec = 20 (decimal) = 0014h

MSTR Transaction #2

The Control Block and Data Block registers for the second MSTR must be loaded with the following data before the MSTR block is executed. This MSTR will ENTER data into Non-Volatile memory on the drive at node #2.

CONTROL BLOCK			
Register Number	Register Description	Register Data	Data Description
40200	Operation Code	0001h	0001h = Write to Multiple Registers
40201	Network Error Code	0000h	The error code returned by Modbus Plus communications
40202	Number of Registers	0001h	Write to 1 register
40203	Data Register Code	FFFDh	Data code for the "ENTER" command
40204	Routing 1	0002h	Modbus Plus node address of the drive = 0002h
40205	Routing 2	0001h	End of routing path = 0001h (Modbus Plus requirement)
40206	Routing 3	0000h	This routing register is not used, must be set to 0
40207	Routing 4	0000h	This routing register is not used, must be set to 0
40208	Routing 5	0000h	This routing register is not used, must be set to 0

DATA BLOCK			
Register Number	Register Description	Register Data	Data Description
40210	ENTER data into Non-Volatile memory	0000h	To ENTER data into Non-Volatile memory, set this register to '0'



CAUTION

USE THE 'ENTER' COMMAND ONLY WHEN NECESSARY!

The life of the Non-Volatile EEPROM on the IMPULSE Series 3 will support a finite number of operations. This means that the 'ENTER' command can only be used a maximum of 100,000 times to store data in the EEPROM. After the specified number of operations, the EEPROM may fault (ERR), requiring the IMPULSE Series 3 control board to be replaced.

Example #6

Write a Global Frequency Reference Multiplier to Drive #2

This example will write a global frequency reference multiplier of 0.500 to drive #2. The global frequency reference multiplier register is data code F201h in the Satellite Internal Register Group. The value of the multiplier can range from 0.001 to 9.999. Each drive that receives a global frequency reference will multiply the value received by the value in their Register 002h.

NOTE

For this operation to be valid, each drive must be initialized to receive global data. This is done by sending the address of the PLC/host device (source of global data) to F200h.

In this example, an input to the PLC will be used to initiate the MSTRs that will write the reference multiplier to drive #2. The input will be addressed at 10006.

Since the Receive Global Data Register and the Global Reference Multiplier Register can only be written to one word at a time, only two MSTR transactions will be needed. The following MSTR transactions should be performed:

#	MSTR Transaction	Control Registers	Data Registers
1	Write to the Global Write Source Data Register Multiplier Register on drive #2	40220	40230
2	Write to the Global Reference Multiplier Register on drive #2	40240	40250

The MSTR functions inserted into the ladder logic would look like:

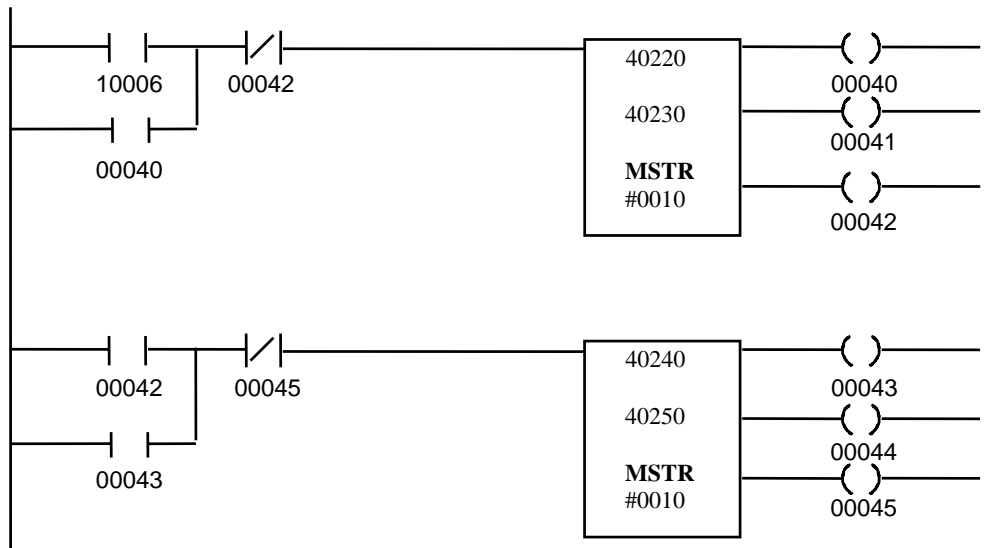

MSTR Transaction #1

In this example, the MSTR blocks are executed sequentially. The Control Block and Data Block registers for the first MSTR must be loaded with the following data before the MSTR block is executed. This MSTR writes to the Receive Global Source Data Register on drive #2.

CONTROL BLOCK			
Register Number	Register Description	Register Data	Data Description
40220	Operation Code	0001h	0001h = Write to Multiple Registers
40221	Network Error Code	0000h	The error code returned by Modbus Plus communications
40222	Number of Registers	0001h	Write to 1 consecutive register
40223	Data Register Code	F200h	Global Write Data Register Code
40224	Routing 1	0002h	Modbus Plus node address of the drive = 0002h
40225	Routing 2	0001h	End of routing path = 0001h (Modbus Plus requirement)
40226	Routing 3	0000h	This routing register is not used, must be set to 0
40227	Routing 4	0000h	This routing register is not used, must be set to 0
40228	Routing 5	0000h	This routing register is not used, must be set to 0

DATA BLOCK			
Register Number	Register Description	Register Data	Data Description
40230	Receive Global Data	0001h	0001h = address of the PLC/host device (the source of global data)

MSTR Transaction #2

The Control Block and Data Block registers for the second MSTR must be loaded with the following data before the MSTR block is executed. This MSTR writes to the Global Frequency Reference Multiplier Register on drive #2.

CONTROL BLOCK			
Register Number	Register Description	Register Data	Data Description
40240	Operation Code	0001h	0001h = Write to Multiple Registers
40241	Network Error Code	0000h	The error code returned by Modbus Plus communications
40242	Number of Registers	0001h	Write to 1 consecutive register
40243	Data Register Code	F201h	Global Write Data Register
40244	Routing 1	0002h	Modbus Plus node address of the drive = 0002h
40245	Routing 2	0001h	End of routing path = 0001h (Modbus Plus requirement)
40246	Routing 3	0000h	This routing register is not used, must be set to 0
40247	Routing 4	0000h	This routing register is not used, must be set to 0
40248	Routing 5	0000h	This routing register is not used, must be set to 0

DATA BLOCK			
Register Number	Register Description	Register Data	Data Description
40250	Global Frequency Reference Multiplier	01F4h	0500 (decimal) = .500 multiplier. Frequency in 002h register is multiplied by .500 on drive 2.

Example #7

Read Drive Parameter Registers (b1-xx's, Cx-xx's, dx-xxs, and Ex-xx's) from Drive #3

This example will read drive parameter registers from drive #3. In this example, an input to the PLC will be used to initiate the MSTRs that will read the drive parameters. This input will be addressed at 10007.

This example requires multiple MSTR transactions. The following MSTR transactions will be performed:

#	MSTR Transaction	Control Registers	Data Registers
1	Read b1-xx parameters (registers 180h – 189h)	40260	40270
2	Read Cx-xx parameters (registers 1C4h – 217h)	40280	40290
3	Read dx-xx parameters (registers 23Bh – 283h)	40380	40390
4	Read Ex-xx parameters (registers 300h - 312h)	40440	40450

The MSTR functions inserted into the ladder logic would look like:

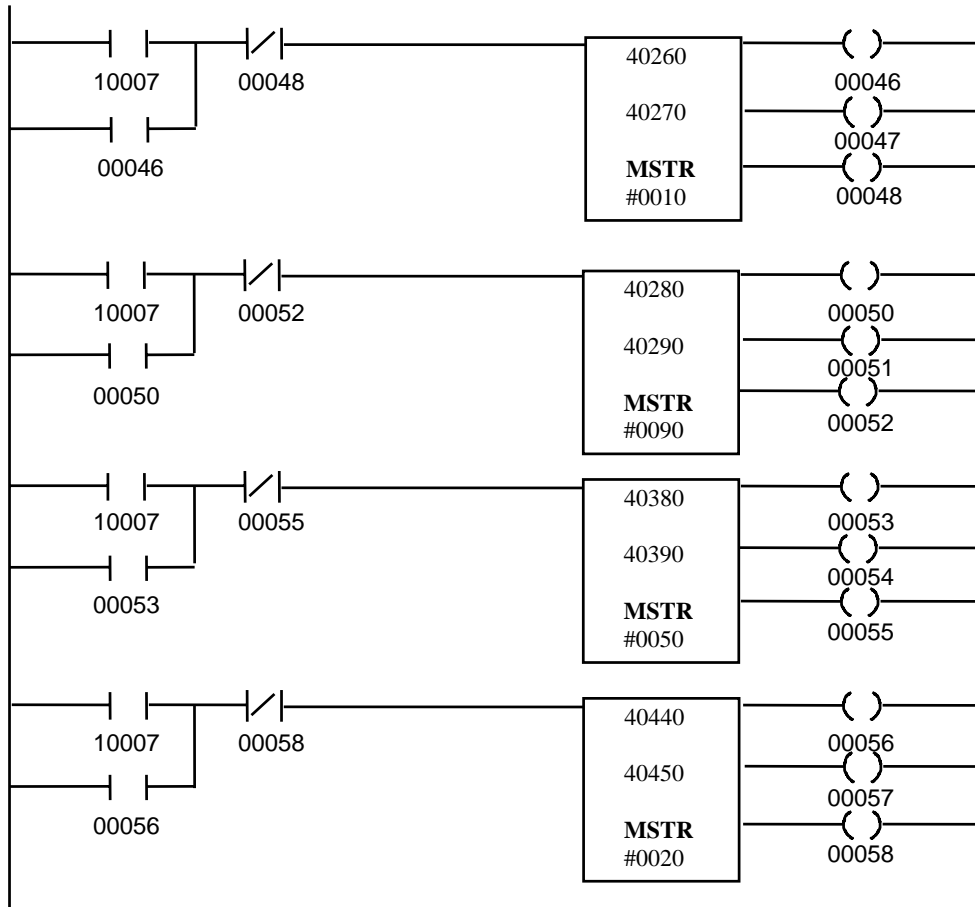

MSTR Transaction #1

In this example, the MSTR blocks are executed sequentially. The Control Block registers for the first MSTR must be loaded with the following data before the MSTR block is executed. This MSTR reads b1-01 through b1-10.

CONTROL BLOCK			
Register Number	Register Description	Register Data	Data Description
40260	Operation Code	0002h	0002h = Read from Multiple Registers
40261	Network Error Code	0000h	The error code returned by Modbus Plus communication
40262	Number of Registers	000Ah	Read from 10 consecutive registers
40263	Data Register Code	0180h	0180h = start of b1-xx parameters.
40264	Routing 1	0003h	Modbus Plus node address of the drive = 0003h
40265	Routing 2	0001h	End of routing path = 0001h (Modbus Plus requirement)
40266	Routing 3	0000h	This routing register is not used, must be set to 0
40267	Routing 4	0000h	This routing register is not used, must be set to 0
40268	Routing 5	0000h	This routing register is not used, must be set to 0

The Data Block registers for the first MSTR will be filled with the following data after the MSTR is completed.

DATA BLOCK			
Register Number	Register Description	Register Data	Data Description
40270	b1-01	READ	Reference 1
40271	b1-02	READ	Reference 2
⇓	⇓	⇓	⇓
40306	b1-09	READ	Reference 9
40307	b1-10	READ	Reference 10

MSTR Transaction #2

The Control Block registers for the second MSTR must be loaded with the following data before the MSTR block is executed. This MSTR reads C1-01 through C11-06.

CONTROL BLOCK			
Register Number	Register Description	Register Data	Data Description
40280	Operation Code	0002h	0002h = Read from Multiple Registers
40281	Network Error Code	0000h	The error code returned by Modbus Plus communications
40282	Number of Registers	0055h	Read from 85 consecutive registers
40283	Data Register Code	1C4h	1C4h = start of Cx-xx parameters
40284	Routing 1	0003h	Modbus Plus node address of drive = 0003h
40285	Routing 2	0001h	End of routing path = 0001h (Modbus Plus requirement)
40286	Routing 3	0000h	This routing register is not used, must be set to 0
40287	Routing 4	0000h	This routing register is not used, must be set to 0
40288	Routing 5	0000h	This routing register is not used, must be set to 0

The Data Block registers for the second MSTR will be filled with the following data when the MSTR is completed.

DATA BLOCK			
Register Number	Register Description	Register Data	Data Description
40290	C1-01	READ	Quick Stop 0/1
40291	C1-02	READ	Quick Stop Time
⇓	⇓	⇓	⇓
40374	C1-06	READ	Slack Cable Detect Speed 2

MSTR Transaction #3

The Control Block registers for the third MSTR must be loaded with the following data before the MSTR block is executed. This MSTR reads d1-01 through d11-02.

CONTROL BLOCK			
Register Number	Register Description	Register Data	Data Description
40380	Operation Code	0002h	0002h = Read from Multiple Registers
40381	Network Error Code	0000h	The error code returned by Modbus Plus communications
40382	Number of Registers	0028h	Read from 40 consecutive registers
40383	Data Register Code	23Bh	23Bh = start of dx-xx parameters
40384	Routing 1	0003h	Modbus Plus node address of drive = 0003h
40385	Routing 2	0001h	End of routing path = 0001h (Modbus Plus requirement)
40386	Routing 3	0000h	This routing register is not used, must be set to 0
40387	Routing 4	0000h	This routing register is not used, must be set to 0
40388	Routing 5	0000h	This routing register is not used, must be set to 0

The Data Block registers for the third MSTR will be filled with the following data when the MSTR is completed.

DATA BLOCK			
Register Number	Register Description	Register Data	Data Description
40390	d1-01	READ	DCInj Start Frequency
40391	d1-02	READ	DCInj Current
⇓	⇓	⇓	⇓
40429	d11-01	READ	Hunt Prevention Select
40430	d11-02	READ	Hunt Prevention Gain

MSTR Transaction #4

The Control Block registers for the fourth MSTR must be loaded with the following data before the MSTR block is executed. This MSTR reads E1-01 through E2-05.

CONTROL BLOCK			
Register Number	Register Description	Register Data	Data Description
40440	Operation Code	0002h	0002h = Read from Multiple Registers
40441	Network Error Code	0000h	The error code returned by Modbus Plus communications
40442	Number of Registers	0012h	Read from 18 consecutive registers
40443	Data Register Code	0300h	0300h = start of Ex-xx parameters
40444	Routing 1	0003h	Modbus Plus node address of drive = 0003h
40445	Routing 2	0001h	End of routing path = 0001h (Modbus Plus requirement)
40446	Routing 3	0000h	This routing register is not used, must be set to 0
40447	Routing 4	0000h	This routing register is not used, must be set to 0
40448	Routing 5	0000h	This routing register is not used, must be set to 0

The Data Block registers for the fourth MSTR will be filled with the following data when the MSTR is completed.

DATA BLOCK			
Register Number	Register Description	Register Data	Data Description
40450	E1-01	READ	Input Voltage Setting
40451	E1-02	READ	Motor Selection
⇓	⇓	⇓	⇓
40467	E2-04	READ	Number of Motor Poles
40468	E2-05	READ	Motor Terminal Resistance

Example #8

Write Drive Parameter Registers (b1-xx's, Cx-xx's, dx-xx's, and Ex-xx's) to Drive #3

This example will write all of the drive parameters to drive #3. After writing the drive parameters, the new data will be stored in Volatile memory with the 'ACCEPT' command, which allows the drive to run after parameter change. In this example, an input to the PLC will be used to initiate the MSTRs that will write the drive parameters. This input will be addressed at 10008.

This example requires multiple MSTR transactions. The following MSTR transactions will be performed:

#	MSTR Transaction	Control Registers	Data Registers
1	Write b1-xx parameters to drive at node #3	40470	40480
2	Write Cx-xx parameters to drive at node #3	40490	40500
3	Write dx-xx parameters to drive at node #3	40590	40600
4	Write Ex-xx parameters to drive at node #3	40650	40660
5	Write the ACCEPT command	40670	40680

The MSTR functions inserted into the ladder logic would look like:

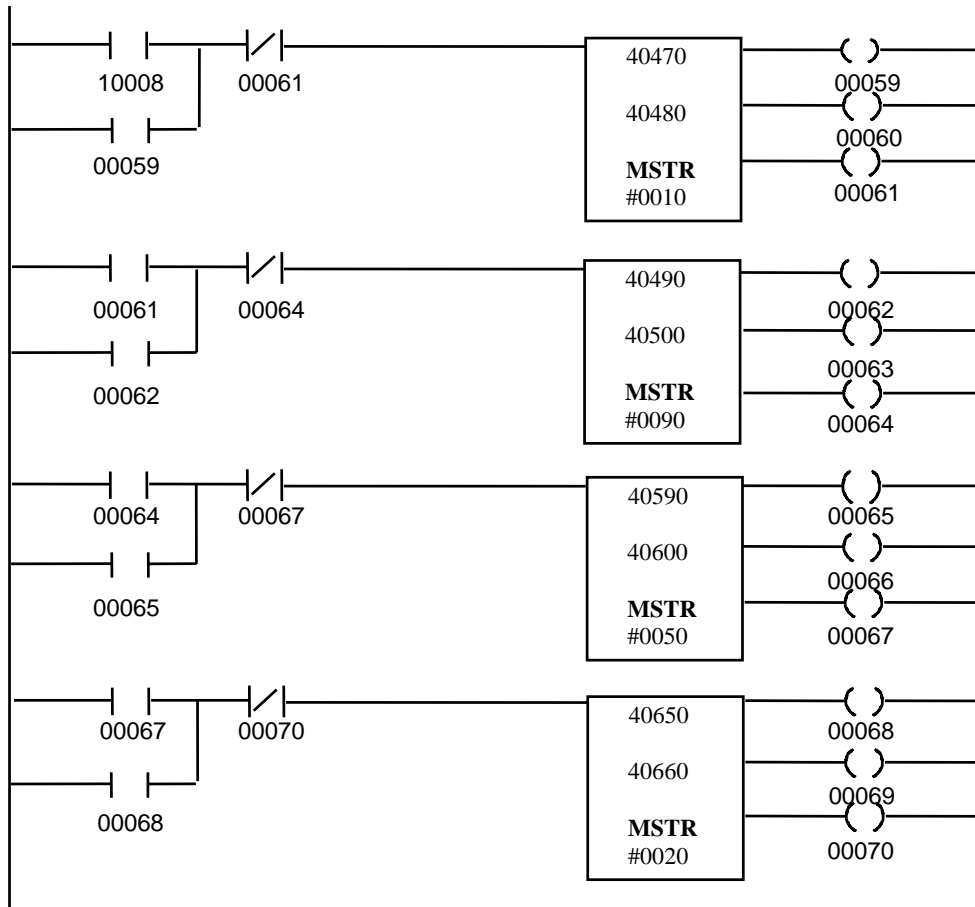

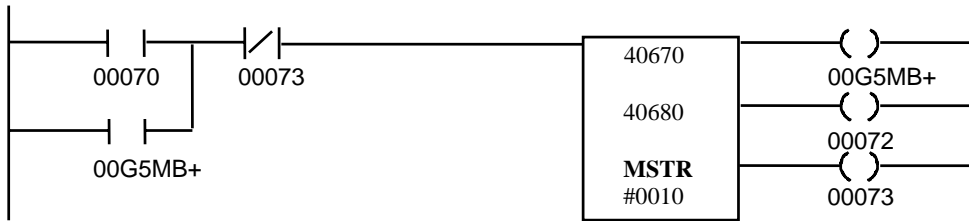

MSTR Transaction #1

In this example, the MSTR blocks are executed sequentially. The Control Block and Data Block registers for the first MSTR must be loaded with the following data before the MSTR block is executed. This MSTR writes b1-01 through b1-10.

CONTROL BLOCK			
Register Number	Register Description	Register Data	Data Description
40470	Operation Code	0001h	0001h = Write to Multiple Registers
40471	Network Error Code	0000h	The error code returned by Modbus Plus communications
40472	Number of Registers	00Ah	Write to 10 consecutive registers
40473	Data Register Code	0180h	0180h = the start of bx-xx parameters
40474	Routing 1	0003h	Modbus Plus node address of the drive = 0003h
40475	Routing 2	0001h	End of routing path = 0001h (Modbus Plus requirement)
40476	Routing 3	0000h	This routing register is not used, must be set to 0
40477	Routing 4	0000h	This routing register is not used, must be set to 0
40478	Routing 5	0000h	This routing register is not used, must be set to 0

DATA BLOCK			
Register Number	Register Description	Register Data	Data Description
40480	b1-01	WRITE	Reference 1
40481	b1-02	WRITE	Reference 2
↓	↓	↓	↓
40488	b1-09	WRITE	Reference 9
40489	b1-10	WRITE	Reference 10

MSTR Transaction #2

The Control Block and Data Block registers for the second MSTR must be loaded with the following data before the MSTR block is executed. This MSTR writes C1-01 through C13-02.

CONTROL BLOCK			
Register Number	Register Description	Register Data	Data Description
40490	Operation Code	0001h	0001h = Write to Multiple Registers
40491	Network Error Code	0000h	The error code returned by Modbus Plus communications
40492	Number of Registers	0055h	Write to 85 consecutive registers
40493	Data Register Code	1C4h	1C4h = start of Cx-xx parameters
40494	Routing 1	0003h	Modbus Plus node address of the drive = 0003h
40495	Routing 2	0001h	End of routing path = 0001h (Modbus Plus requirement)
40496	Routing 3	0000h	This routing register is not used, must be set to 0
40497	Routing 4	0000h	This routing register is not used, must be set to 0
40498	Routing 5	0000h	This routing register is not used, must be set to 0

DATA BLOCK			
Register Number	Register Description	Register Data	Data Description
40500	C1-01	WRITE	Quick Stop 0/1
40501	C1-02	WRITE	Quick Stop Time
⇓	⇓	⇓	⇓
40584	C11-06	WRITE	Slack Cable Detect Speed 2

MSTR Transaction #3

The Control Block and Data Block registers for the third MSTR must be loaded with the following data before the MSTR block is executed. This MSTR writes d1-01 through d11-02.

CONTROL BLOCK			
Register Number	Register Description	Register Data	Data Description
40590	Operation Code	0001h	0001h = Write to Multiple Registers
40591	Network Error Code	0000h	The error code returned by Modbus Plus communications
40592	Number of Registers	0031h	Write to 40 consecutive registers
40593	Data Register Code	23Bh	23Bh = start of dx-xx parameters
40594	Routing 1	0003h	Modbus Plus node address of the drive = 0003h
40595	Routing 2	0001h	End of routing path = 0001h (Modbus Plus requirement)
40596	Routing 3	0000h	This routing register is not used, must be set to 0
40597	Routing 4	0000h	This routing register is not used, must be set to 0
40598	Routing 5	0000h	This routing register is not used, must be set to 0

DATA BLOCK			
Register Number	Register Description	Register Data	Data Description
40600	d1-01	WRITE	DCInj Start Frequency
40601	d1-02	WRITE	DCInj Current
⇓	⇓	⇓	⇓
40647	d11-01	WRITE	Hunt Prevention Select
40640	d11-02	WRITE	Hunt Prevention Gain

MSTR Transaction #4

The Control Block registers for the fourth MSTR must be loaded with the following data before the MSTR block is executed. This MSTR writes to E1-01 through E2-05.

CONTROL BLOCK			
Register Number	Register Description	Register Data	Data Description
40650	Operation Code	0001h	0001h = Write to Multiple Registers
40651	Network Error Code	0000h	The error code returned by Modbus Plus communications
40652	Number of Registers	0012h	Write to 18 consecutive registers
40653	Data Register Code	0300h	0300h = start of Ex-xx parameters
40654	Routing 1	0003h	Modbus Plus node address of drive = 0003h
40655	Routing 2	0001h	End of routing path = 0001h (Modbus Plus requirement)
40656	Routing 3	0000h	This routing register is not used, must be set to 0
40657	Routing 4	0000h	This routing register is not used, must be set to 0
40658	Routing 5	0000h	This routing register is not used, must be set to 0

DATA BLOCK			
Register Number	Register Description	Register Data	Data Description
40660	E1-01	WRITE	Input Voltage Setting
40661	E1-02	WRITE	Motor Selection
⇓	⇓	⇓	⇓
40676	E2-04	WRITE	Number of Motor Poles
40677	E2-05	WRITE	Motor Terminal Resistance

MSTR Transaction #5

The Control Block and Data Block registers for the fifth MSTR must be loaded with the following data before the MSTR block is executed. This MSTR will ACCEPT data into Volatile memory and allow the drive to run after a parameter change on drive #3.

CONTROL BLOCK			
Register Number	Register Description	Register Data	Data Description
40670	Operation Code	0001h	0001h = Write to Multiple Registers
40671	Network Error Code	0000h	The error code returned by Modbus Plus communications
40672	Number of Registers	0001h	Write to 1 register
40673	Data Register Code	FFDDh	FFDDh = ACCEPT command
40674	Routing 1	0003h	Modbus Plus node address of the drive = 0003h
40675	Routing 2	0001h	End of routing path = 0001h (Modbus Plus requirement)
40676	Routing 3	0000h	This routing register is not used, must be set to 0
40677	Routing 4	0000h	This routing register is not used, must be set to 0
40678	Routing 5	0000h	This routing register is not used, must be set to 0

DATA BLOCK			
Register Number	Register Description	Register Data	Data Description
40680	ACCEPT data into Volatile memory	0000h	To ACCEPT data into Volatile memory, set this register to '0'

Example #9

Read the Drive Status Registers from Drive #2, #3, and #4

This example will read the various drive status registers (such as Drive Status Signals, Drive Fault Contents, Communication Data Link Status, Frequency Reference, Output Reference, Output Current, and DC Bus Voltage) from all of the IMPULSE Series 3s. In this example, an input to the PLC will be used to initiate the MSTRs that will read the drive status. This input will be addressed at 10009.

Since all of these drive status registers are consecutive, this example only requires one read MSTR transactions per drive. The following MSTR transactions will be performed:

#	MSTR Transaction	Control Registers	Data Registers
1	Read drive status (F000h - F00Fh) from drive #2	40690	40700
2	Read drive status (F000h - F00Fh) from drive #3	40720	40730
3	Read drive status (F000h - F00Fh) from drive #4	40750	40760

The MSTR functions inserted into the ladder logic would look like:

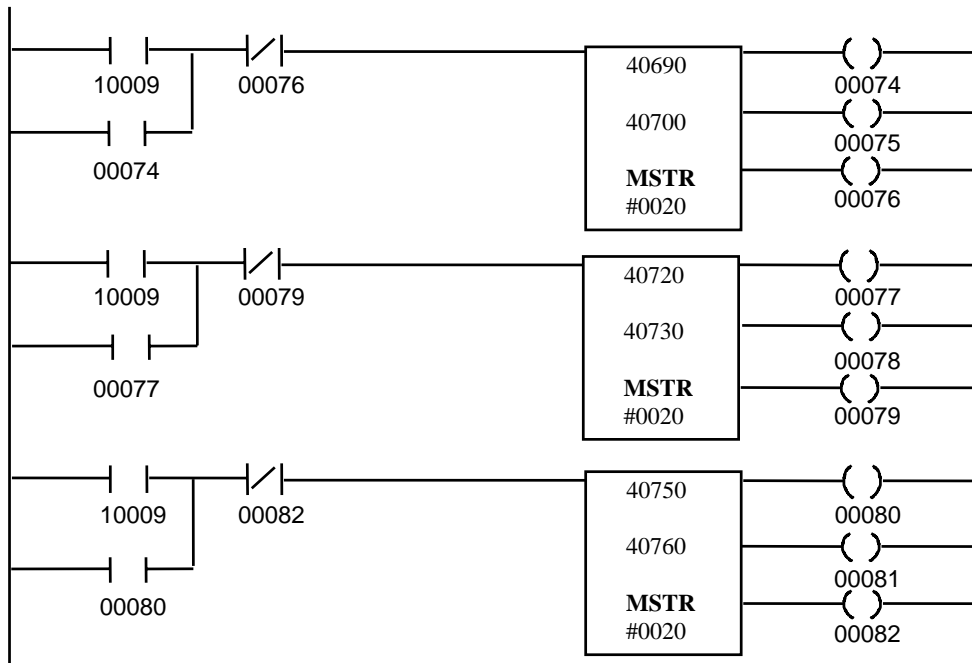

MSTR Transaction #1

In this example, the MSTR blocks are executed simultaneously. The Control Block registers for the first MSTR must be loaded with the following data before the MSTR block is executed. This MSTR reads drive status from drive #2.

CONTROL BLOCK			
Register Number	Register Description	Register Data	Data Description
40690	Operation Code	0002h	0002h = Read from Multiple Registers
40691	Network Error Code	0000h	The error code returned by Modbus Plus communications
40692	Number of Registers	0010h	Read from 16 consecutive registers
40693	Data Register Code	F000h	F000h = Drive Status Signals
40694	Routing 1	0002h	Modbus Plus node address of the drive = 0002h
40695	Routing 2	0001h	End of routing path = 0001h (Modbus Plus requirement)
40696	Routing 3	0000h	This routing register is not used, must be set to 0
40697	Routing 4	0000h	This routing register is not used, must be set to 0
40698	Routing 5	0000h	This routing register is not used, must be set to 0

The Data Block registers for the first MSTR will be filled with the following data after the MSTR is completed.

DATA BLOCK			
Register Number	Register Description	Register Data	Data Description
40700	Drive Status Signals	READ	RUN/STOP, FWD/REV, Drive Ready, etc.
40701	Motor Speed	READ	Motor Speed
40702	Torque Reference	READ	Torque Reference
40703	not used	n/a	n/a
40704	Speed Reference	READ	Frequency command to drive
40705	Output Frequency	READ	(0.1 Hz) Frequency at the drive
40706	Output Current	READ	Current at the output
40707	Analog Input	READ	Control Circuit Term 14 Input Voltage
40708	DC Bus Voltage	READ	(1.0 V) DC Bus voltage
40709	Fault Content 1	READ	Overcurrent, Overvoltage, Drive Overload, etc.
40710	Fault Content 2	READ	
40711	Fault Content 3	READ	
40712	Analog Input	READ	Control Circuit Term 16 Input Voltage
40713	Digital Input	READ	Input Terminal Status
40714	Analog Input	READ	Control Circuit Term 13 Input Voltage
40715	not used	n/a	n/a

MSTR Transaction #2

The Control Block registers for the second MSTR must be loaded with the following data before the MSTR block is executed. This MSTR reads the drive status from drive #3.

CONTROL BLOCK			
Register Number	Register Description	Register Data	Data Description
40720	Operation Code	0002h	0002h = Read from Multiple Registers
40721	Network Error Code	0000h	The error code returned by Modbus Plus communications
40722	Number of Registers	0010h	Read from 16 consecutive registers
40723	Data Register Code	F000h	F000h = Drive Status Signals
40724	Routing 1	0003h	Modbus Plus node address of the drive = 0003h
40725	Routing 2	0001h	End of routing path = 0001h (Modbus Plus requirement)
40726	Routing 3	0000h	This routing register is not used, must be set to 0
40727	Routing 4	0000h	This routing register is not used, must be set to 0
40728	Routing 5	0000h	This routing register is not used, must be set to 0

The Data Block registers for the second MSTR will be filled with the following data after the MSTR is completed.

DATA BLOCK			
Register Number	Register Description	Register Data	Data Description
40730	Drive Status Signals	READ	RUN/STOP, FWD/REV, Drive Ready, etc.
40731	Motor Speed	READ	Motor Speed
40732	Torque Reference	READ	Torque Reference
40733	not used	n/a	n/a
40734	Speed Reference	READ	Frequency command to drive
40735	Output Frequency	READ	(0.1 Hz) Frequency at the drive
40736	Output Current	READ	Current at the output
40737	Analog Input	READ	Control Circuit Term 14 Input Voltage
40738	DC Bus Voltage	READ	(1.0 V) DC Bus voltage
40739	Fault Content 1	READ	Overcurrent, Overvoltage, Drive Overload, etc.
40740	Fault Content 2	READ	
40741	Fault Content 3	READ	
40742	Analog Input	READ	Control Circuit Term 16 Input Voltage
40743	Digital Input	READ	Input Terminal Status
40744	Analog Input	READ	Control Circuit Term 13 Input Voltage
40745	not used	n/a	n/a

MSTR Transaction #3

The Control Block registers for the third MSTR must be loaded with the following data before the MSTR block is executed. This MSTR reads drive status from drive #4.

CONTROL BLOCK			
Register Number	Register Description	Register Data	Data Description
40750	Operation Code	0002h	0002h = Read from Multiple Registers
40751	Network Error Code	0000h	The error code returned by Modbus Plus communications
40752	Number of Registers	0010h	Read from 16 consecutive registers
40753	Data Register Code	F000h	F000h = Drive Status Signals
40754	Routing 1	0004h	Modbus Plus node address of the drive = 0004h
40755	Routing 2	0001h	End of routing path = 0001h (Modbus Plus requirement)
40756	Routing 3	0000h	This routing register is not used, must be set to 0
40757	Routing 4	0000h	This routing register is not used, must be set to 0
40758	Routing 5	0000h	This routing register is not used, must be set to 0

The Data Block registers for the third MSTR will be filled with the following data after the MSTR is completed.

DATA BLOCK			
Register Number	Register Description	Register Data	Data Description
40760	Drive Status Signals	READ	RUN/STOP, FWD/REV, Drive Ready, etc.
40761	Motor Speed	READ	Motor Speed
40762	Torque Reference	READ	Torque Reference
40763	not used	n/a	n/a
40764	Speed Reference	READ	Frequency command to drive
40765	Output Frequency	READ	(0.1 Hz) Frequency at the drive
40766	Output Current	READ	Current at the output
40767	Analog Input	READ	Control Circuit Term 14 Input Voltage
40768	DC Bus Voltage	READ	(1.0 V) DC Bus voltage
40769	Fault Content 1	READ	Overcurrent, Overvoltage, Drive Overload, etc.
40770	Fault Content 2	READ	
40771	Fault Content 3	READ	
40772	Analog Input	READ	Control Circuit Term 16 Input Voltage
40773	Digital Input	READ	Input Terminal Status
40774	Analog Input	READ	Control Circuit Term 13 Input Voltage
40775	not used	n/a	n/a

Chapter 10

Application Notes

- Register Types
- Through-put
- Limitations

Register Types

The Modbus Plus Interface board allows the MB+ network access to a drive's internal data registers. The two different types of data registers vary in the method they use to access the drive's internal memory. The two different types are as follows:

- **High Speed Registers** - (0001-000F, F000-F00F) allow direct access to the drive's memory via dual port RAM or shared memory. This allows for very quick access to the drive's memory. The high speed registers are shown in *italics* in Appendix A.
- **Serial Registers** - (0020-050D, F100-F10F) allow access to the drive's memory via a serial interface. Data is transmitted to and received from the drive's memory serially, which is considerably slower than high speed registers.

Through-put

The following graphs compare the time it takes to complete the given read or write operation for a given number of data registers or block size.

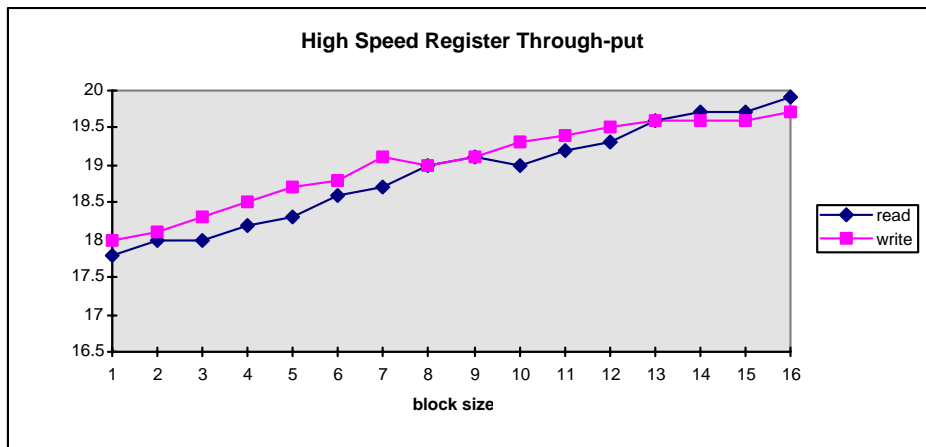

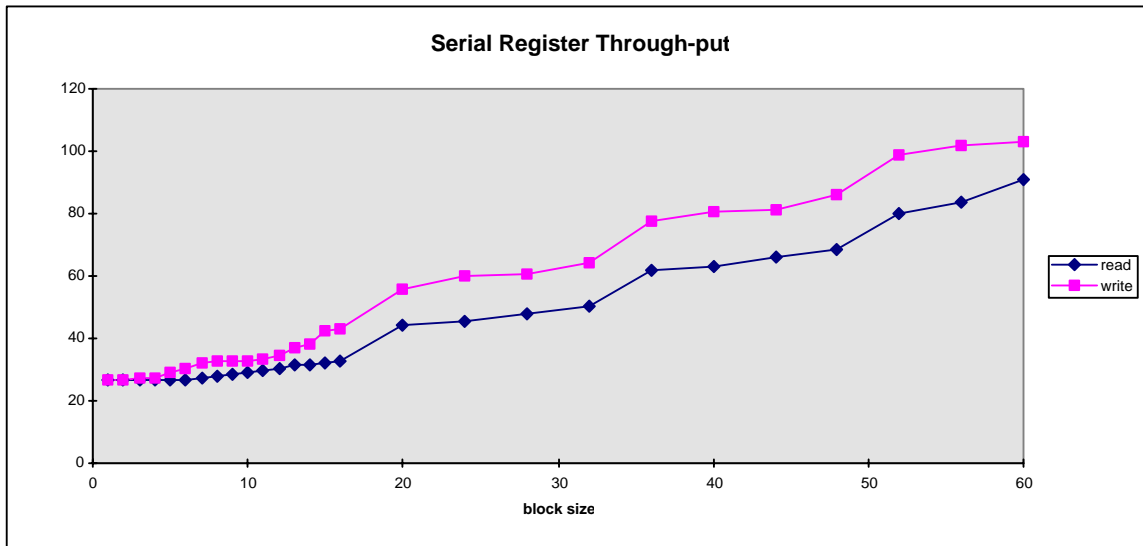

ENTER Command	ACCEPT Command
400 msec to complete	190 msec to complete

Enabling Global Data

High Speed Registers		Serial Registers	
global read enabled	global read & write enabled	global read enabled	global read & write enabled
+ 1.3 msec	+ 3 msec	+ 4 msec	+ 4 msec

Passing Data Through on Bridge (NW-BP85)

+ 5 msec

Enabling Cable Loss

no effect

Drive in RUN

no effect

Limitations

- The IMPULSE Series 3 with the Modbus Plus Interface board is seen as a **slave device** on the MB+ network.
- If **global write is enabled** via F200, the operation command (001h) and frequency reference (002h) must come via a global write, otherwise erratic operation of the drive could result.
- With the cable loss detection switch on, **cable loss** is not detected, after drive power-up, until the drive's Modbus Plus Interface board receives its first MB+ command (either a non-global read or write).
- If both run forward (word 001h - bit 0) and run reverse (word 001h - bit 1) are set to 1, an “ **EF - External Fault** ” will be generated by the drive.
- The following registers can only be accessed via one word blocks (**MSTR length=1**):

F200	r/w	Global Write Data Node Number (Global Write Enable)
F201	r/w	Global Frequency Reference Multiplier
F202	r	Model Number of Drive

- If any registers are changed via MB+, with the exception of the “Run Operative Parameters” (shown in Table 10-1 of this Manual), an ‘ACCEPT’ or ‘ENTER’ command must be sent to the drive in order for the drive to be given a **RUN** command.
- If any registers are changed via MB+, an ‘ACCEPT’ or ‘ENTER’ command must be sent to the drive in order for parameters to be changed via the drive's keypad. If an ‘ACCEPT’ or ‘ENTER’ command is needed, the drive will display “**Busy - Write Protected**” when a parameter is attempted to be changed via the keypad.
- Limit your use of the ‘**ENTER**’ command. The life of the Non-Volatile EEPROM on the IMPULSE Series 3 will support a finite number of operations. This means that the ‘ENTER’ command can only be used a maximum of 100,000 times to store data in the EEPROM. After the specified number of operations, the EEPROM may fault (ERR), requiring the IMPULSE Series 3 to be replaced.

Run Operative Parameters (Series 3)

Table 10-1

Register No.	Parameter	Parameter Description	Initial Value	Unit
100h	A1-00	Language Selection	0	-
101h	A1-01	Access Level	2	-
180h	B1-01	Frequency Ref. 1	15.00	Hz
181h	B1-02	Frequency Ref. 1	30.00	Hz
182h	B1-03	Frequency Ref. 1	60.00	Hz
183h	B1-04	Frequency Ref. 1	45.00	Hz
184h	B1-05	Frequency Ref. 1	60.00	Hz
185h	B1-06	Frequency Ref. 1	0.00	Hz
186h	B1-07	Frequency Ref. 1	0.00	Hz
187h	B1-08	Frequency Ref. 1	0.00	Hz
188h	B109	Frequency Ref. 1	0.00	Hz
189h	B1-10	Frequency Ref. 1	0.00	Hz
18Ah	B1-11	Frequency Ref. 1	0.00	Hz
18Bh	B1-12	Frequency Ref. 1	0.00	Hz
18Ch	B1-13	Frequency Ref. 1	0.00	Hz
18Dh	B1-14	Frequency Ref. 1	0.00	Hz
18Eh	B1-15	Frequency Ref. 1	0.00	Hz
18Fh	B1-16	Frequency Ref. 1	0.00	Hz
190h	B1-17	Jog Reference	6.00	Hz
194h	B2-03	Master Speed Ref Lower Limit	2	%
1A1h	B5-01	Acceleration Time 1	5.0	Sec.
1A2h	B5-02	Deceleration Time 1	3.0	Sec.
1A3h	B5-03	Acceleration Time 2	2.0	Sec.
1A4h	B5-04	Deceleration Time 2	2.0	Sec.
1ACh	B5-12	Acceleration Time 3	3.0	Sec.
1ADh	B5-13	Deceleration Time 3	3.0	Sec.
1AEh	B5-14	Acceleration Time 4	3.0	Sec.
1AFh	B5-15	Deceleration Time 4	3.0	Sec.
1C5h	C1-02	Quick Stop Time	1.0	Sec.
1C7h	C1-04	Plug Reverse Decel Time	2.0	Sec.
1C8h	C1-05	Plug Reverse Accel Time	2.0	Sec.
1CCh	C3-02	Upper Limit 1 Decel Time	1.0	Sec.
1CDh	C3-03	Upper Limit 2 Stop Time	0.5	Sec.
1CFh	C3-05	Lower Limit 1 Decel Time	1.0	Sec.
1D0h	C3-06	Lower Limit 2 Stop Time	1.0	Sec.
1D4h	C4-01	Load Float Time 2	10	Sec.
1D6h	C4-03	Load Float Count	10	-
1FCh	C8-10	Load Float Time	10	Sec.
1FEh	C8-12	BE6 Detect Timer	5.0	Sec.
201h	C8-15	Load Float Extension Timer	10	Sec.
207h	C8-21	Height Measure	250	Rev.

Run Operative Parameters (Series 3) (Con't)

Table 10-1

Register No.	Parameter	Parameter Description	Initial Value	Unit
21Dh	C11-12	Gear Ratio Numerator	10000	-
21Eh	C11-13	Gear Ratio Denominator	10000	-
243h	D2-01	Slip Compensation Gain	0.0 / 1.0	-
249h	D3-01	Torque Compensation Gain	1.00	-
24Fh	D4-01	ASR Proportional Gain 1	1.00	-
250h	D4-02	ASR Integral Time 1	0.500 / .20	Sec.
251h	D4-03	ASR Proportional Gain 2	30.00	-
252h	D4-04	ASR Integral Time 2	0.100 / 0.050	Sec.
399h	F4-02	AO-08/AO-12 Channel 1 Gain	100.0	%
39Bh	F4-04	AO-08/AO-12 Channel 2 Gain	100.0	%
39Ch	F4-05	Channel 1 AO Bias	0.0	%
39Dh	F4-06	Channel 2 AO Bias	0.0	%
411h	H3-02	Terminal A1 Gain	100.0	%
412h	H3-03	Terminal A1 Signal Bias	0.0	%
415h	H3-06	Multi-function Analog Input Term. A3 Gain	100.0	%
417h	H3-07	Multi-function Analog Input Term. A3 Bias	0.0	%
419h	H3-10	Multi-function Analog Input Term. A2 Gain	100.0	%
41Ah	H3-11	Multi-function Analog Input Term. A2 Bias	0.0	%
41Eh	H4-02	Multi-function Analog Output 1 Gain	100.0	%
41Fh	H4-03	Multi-function Analog Output 1 Bias	0.0	%
421h	H4-05	Multi-function Analog Output 2 Gain	100.0	%
422h	H4-06	Multi-function Analog Output 2 Bias	0.0	%
42Dh	H6-02	Pulse Input Scaling	1440	Hz
42Eh	H6-03	Pulse Input Gain	100.0	%
42Fh	H6-04	Pulse Input Bias	0.0	%
430h	H6-05	Pulse Input Filter Time	0.1	Sec.
431h	H6-06	Pulse Output Selection	2	-
432h	H6-07	Pulse Output Scaling	1440	Hz
500h	O1-01	Monitor Selection	6	-
501h	O1-02	Monitor Selection after Power-up	1	-
504h	O1-05	LCD Brightness Adjust	3	-

Appendix A

Data Registers

- Global Data
- Command Data
- Monitor Data
- Drive Parameter Register
- Special Data

Global Write Registers (write only)

REGISTER (in hex)	FUNCTION	BIT NO.	DATA SET	DESCRIPTION
001h	Operational Command	0	0	Stop Forward
			1	Run Forward
		1	0	Stop Reverse
			1	Run Reverse
		2		Terminal 3 Function
		3		Terminal 4 Function
		4		Terminal 5 Function
		5		Terminal 6 Function
		6		Terminal 7 Function
		7		Terminal 8 Function
8		1	External Fault	
9		1	Fault Reset	
002h	Frequency Reference			Frequency Reference (6000 = 60.00Hz) (1)

(1) Scaling depends on the setting of o1-03

Global Data (read only)

REGISTER (in hex)	FUNCTION	BIT NO.	DATA SET	DESCRIPTION
001h	Operational Command	0	0	Stop Forward
			1	Run Forward
		1	0	Stop Reverse
			1	Run Reverse
		2		Terminal 3 Function
		3		Terminal 4 Function
		4		Terminal 5 Function
		5		Terminal 6 Function
		6		Terminal 7 Function
		7		Terminal 8 Function
8	1	External Fault		
		9	1	Fault Reset
F005h	Output Frequency	Output Frequency of drive (in 0.1 Hz) (1)		
F006h	Output Current	10V/Drive rated current (2)		
F008h	DC Bus Voltage	DC Bus Voltage (in 1 V)		
F000h	Drive Status	0	1	Run
		1	1	Zero-Speed
		2	1	Reverse Run
		3	1	Reset Signal Input
		4	1	Speed Agree
		5	1	Drive Operation Ready
		6	1	Minor Fault
		7	1	Major Fault
		8	1	not used
		9	1	During Momentary Power Ride-through
		A	1	Local / Remote
		B		Terminal 9&10 Output
		C		Terminal 25 Output
		D		Terminal 26 Output
		E	1	Motor Selection
F	1	Zero Servo Completion		

(1) Scaling depends on the setting of o1-03

(2) Display unit = 0.01A for models IMPULSE Series 3 2003 thru 2025 and 4001 thru 4011; display unit = 0.1A for models 2033 thru 2300 and 4014 thru 4605.

Global Data (Read only) – continued

REGISTER (in hex)	FUNCTION	BIT NO.	DATA SET	DESCRIPTION
F009h	Existing Fault Code 1	0	1	FU
		1	1	UV1 - DC Bus Undervoltage
		2	1	UV2 - CTL PS Undervoltage
		3	1	UV3 - MC Answerback
		4	1	SC - Short Circuit
		5	1	GF - Ground Fault
		6	1	OC - Over Current
		7	1	OV - Overvoltage
		8	1	OH - Heatsink Overtemperature
		9	1	OH1 - Drive Overheat
		A	1	OL1 - Motor Overload
		B	1	OL2 - Drive Overload
		C	1	OL3 - Overtorque 1
		D	1	OL4 - Overtorque 2
		E	1	RR - Dynamic Braking Transistor
		F	1	RH - Dynamic Braking Resistor
F00Ah	Existing Fault Code 2	0	1	EF3 - External Fault 3
		1	1	EF4 - External Fault 4
		2	1	EF5 - External Fault 5
		3	1	EF6 - External Fault 6
		4	1	EF7 - External Fault 7
		5	1	EF8 - External Fault 8
		6	1	FAN Fault
		7	1	OS - Overspeed
		8	1	DEV - Speed Deviation
		9	1	PGO - PG Open
		A	1	PF - Input Phase Loss
		B	1	LF - Output Phase Loss
		C	1	DCCT Fault
		D	1	OPR – Operator Disconnect
		E	1	ERR - EEPROM R/W Error
		F	1	not used

Global Data (Read only) – continued

REGISTER (in hex)	FUNCTION	BIT NO.	DATA SET	DESCRIPTION
F00Bh	Existing Fault 3	0	1	CE – Modbus Com Error
		1	1	BUS – Option Communication Error
		2	1	E15 – Serial Communication Error
		3	1	E10 – Option CPU Down
		4	1	CF – Out of Control
		5	1	SVE – Zero Servo Fault
		6	1	SVR – Noisy Encoder Fault
		7	1	SNAP – Snap Shaft
		8	1	LCI – Load Check Error
		9	1	BE7 – Brake Welded
		A	1	PGO2 – PG Open During Load Float
		B	1	PROX – PG Compare Fault
		C	1	SYNC – Out of Sync
		D	1	EF0 – Option External Fault
		E	1	Not used
F	1	Not used		

Command Registers (Read/Write)

REGISTER (in hex)	FUNCTION	BIT NO.	DATA SET	DESCRIPTION
001h	Operational Command	0	0	Stop Forward
			1	Run Forward
		1	0	Stop Reverse
			1	Run Reverse
		2		Terminal 3 Function
		3		Terminal 4 Function
		4		Terminal 5 Function
		5		Terminal 6 Function
		6		Terminal 7 Function
		7		Terminal 8 Function
		8		External Fault (EFO)
		9		Fault Reset
		A - F		Not Used
002h	Frequency Reference		Flux Vector mode only (0.1%)	
003h	Torque Reference/Torque Limit		Flux Vector mode only (0.1%)	
004h	Torque Compensation			
005h	Not Supported		(-11V/-1540 to 11V/1540) (5)	
006h	PID Setpoint		(-11V/-1540 to 11V/1540) (6)	
007h	Analog Output 1 Setting	0	Multi-function Contact Output (terminals M0 – M1): “closed” (2)	
008h	Analog Output 2 Setting	1	Multi-function Contact Output (terminals M2 – M4): “closed” (3)	
009h	Digital Output Setting	2	Multi-function Contact Output (terminals M5 – M6): “closed” (4)	
		3 ~ 5	Not Used	
		6	Fault Contact (Terminal MA – MB) enable	
		7	Fault Contact state (Terminal MA – MB) (effective only when bit 6 = ‘1’)	
		8 ~ F	Not Used	

(1) The availability of the MFI terminals vary depending upon the settings of H1-01, H1-02, H1-03, H1-04, H1-05, H1-06 (the multi-function input settings)

(2) Effective when H2-01 = 0Fh.

(3) Effective when H2-02 = 0Fh.

(4) Effective when H2-03 = 0Fh.

(5) Effective when H4-01 = 31h.

(6) Effective when H4-04 = 31h.

(7) Desired frequency of 35.75 Hz requires a value of 3575 in register data code 002h. Scaling depends on the setting of o1-03

Command Registers (Read/Write) - continued

REGISTER (in hex)	FUNCTION	BIT NO.	DESCRIPTION
000Fh	Command Selection Setting	0	Not Used
		1	Enables PID value from register 0006h
		2 ~ B	Not Used
		C	Enables Batch Data Transfer Terminal 5 Input
		D	Enables Batch Data Transfer Terminal 6 Input
		E	Enables Batch Data Transfer Terminal 7 Input
		F	Enables Batch Data Transfer Terminal 8 Input

Monitor Registers (Read/Write)

REGISTER (in hex)	FUNCTION	BIT NO.	DESCRIPTION
0010h	Drive Status	0	Run
		1	Zero-Speed
		2	Reverse Run
		3	Reset Signal Input
		4	Speed Agree
		5	Drive Operation Ready
		6	Minor Fault (Alarm)
		7	Major Fault (Fault)
		8 ~ 10	Not Used
		E	Com Ref Status
		F	Com Ctrl Status
0011h	Operator Status	0	OPE has Occurred
		1	ERR has Occurred
		2	Program Mode
		3	0: Operator 1: PC
		4 ~ F	Not Used
0012h	OPE Number		OPE Description Number
0013h	Inverter Code		G5: 0000h V7: 2040h F7: 2040h

Monitor Registers (Read Only) – Continued

REGISTER (in hex)	FUNCTION	BIT NO.	DESCRIPTION
0014h or 0730h	Existing Fault Code 1	0	PUF – Fuse Blown
		1	UV1 - DC Bus Undervoltage
		2	UV2 - CTL PS Undervoltage
		3	UV3 - MC Answerback
		4	Not Used
		5	GF - Ground Fault
		6	OC - Over Current
		7	OV – Overvoltage
		8	OH - Heatsink Overtemperature
		9	OH1 - Drive Overheat
		A	OL1 - Motor Overload
		B	OL2 - Drive Overload
		C	OT1 - Overtorque 1
		D	OT2 - Overtorque 2
		E	RR - Dynamic Braking Transistor
		F	RH - Dynamic Braking Resistor Overheat
0015h or 0731h	Existing Fault Code 2	0	EF3 - External Fault 3
		1	EF4 - External Fault 4
		2	EF5 - External Fault 5
		3	EF6 - External Fault 6
		4	EF7 - External Fault 7
		5	EF8 - External Fault 8
		6	PGO-1-h - PG CH 1 Open (Hardware Detection)
		7	OS-1 – CH 1Overspeed
		8	DEV-1 - Speed Deviation
		9	PGO-1-S – PG CH 1 Open (Software Detection)
		A	PF - Input Phase Loss
		B	LF - Output Phase Loss
		C	OH3 – Motor Overheat
		D	OPR – Operator Disconnect
		E	ERR - EEPROM R/W Error
		F	OH4 – Motor Overheat 2

Monitor Registers (Read Only) – Continued

REGISTER (in hex)	FUNCTION	BIT NO.	DESCRIPTION
0016h or 0732h	Existing Fault 3	0	CE – Modbus Com Error
		1	BUS – Option Communication Error
		2	E15 – Serial Communication Error
		3	E10 – Option CPU Down
		4	CF – Out of Control
		5	SVE – Zero Servo Fault
		6	EFO – Communication Option External Fault
		7	FBL – PID Feedback Loss
		8	UT1 – Undertorque 1
		9	UT2 – Undertorque 2
		A	OL7 – High Speed Slip Braking Overload
		B	PGO-2-H – PG CH2 Open (Hardware Detection)
		C	OS-2 – CH2 Overspeed
		D	DEV-2 – CH2 Speed Deviation
		E	PG)-S-S – PG CH2 Open (Software Detection)
		F	Not used
0733h	Existing Fault 4	0	Not Used
		1	Not Used
		2	SNAP – Snapped Shaft
		3	LC - Load Check Error
		4	BE1 – Rollback Detected
		5	BE2 – No Current
		6	BE3 – Brake Release No Good
		7	BE7 – Brake Welded
		8	UL3 – Upper Limit 3
		9 ~ F	Not Used

Monitor Registers (Read Only) – Continued

REGISTER (in hex)	FUNCTION	BIT NO.	DESCRIPTION
0017h	CPF Description 1	0 ~ 1	Not Used
		2	CPF02 – Baseblock Circuit
		3	CPF03 – EEPROM Fault
		4	CPF04 – CPU Internal A/D Converter
		5	CPF05 – External A/D Converter
		6	CPF06 – Option Board Connection Error
		7	CPF07 – ASIC Internal RAM Error
		8	CPF08 – Watchdog Timer Fault
		9	CPF09 – CPU-ASIC Mutual Diagnosis Fault
		A	CPF10 – ASIC Version Fault
		B ~ F	Not Used
0018h	CPF Description 2	0	CPF20 – Option A/D Error
		1	CPF21 – Option CPU Down
		2	CPF22 – Option Type Error
		3	CPF23 – Option Board Interconnection Fault
0019h or 734h	Minor Fault Content 1 (Alarm)	4 ~ F	Not Used
		0	UV - DC Bus Undervoltage (No run command)
		1	OV - DC Bus Overvoltage (No run command)
		2	OH - Inverter Overheat
		3	OH2 - Inverter Overheat Warning by MFDI '39H'
		4	OT1 - Overtorque 1
		5	OT2 - Overtorque 2
		6	EF - External Fault (F/R simultaneously)
		7	BB - External Baseblock
		8	EF3 - External Fault Terminal 3
		9	EF4 - External Fault Terminal 4
		A	EF5 - External Fault Terminal 5
		B	EF6 - External Fault Terminal 6
		C	EF7 - External Fault Terminal 7
		D	EF8 - External Fault Terminal 8
		E	SNAP - Snapped Shaft
		F	OS-1 - CH1 Overspeed

Monitor Registers (Read Only) - Continued

REGISTER (in hex)	FUNCTION	BIT NO.	DESCRIPTION
001Ah or 735h	Minor Fault Content 2 (Alarm)	0	DEV-1 - CH1 Speed Deviation
		1	PGO-1-S - PG CH1 Open (Software Detection)
		2	PGO-1-H - PG CH1 Open (Hardware Detection)
		3	CE - Memobus Communication Error
		4	BUS - Communication Option Error
		5	CALL - Serial Comm has not been established (Communication Option)
		6	LC - Load Check Error
		7	BE0 - Brake Answerback Lost during run
		8	DEV-2 - CH2 Speed Bias Exceeded
		9	EF0 - Communication Option External Fault
		A	Can't SW - Motor Switch During Run
		B	FBL - PID Feedback Loss
		C	CALL - Serial Comm has not been established (Memobus)
		D	UT1 - Undertorque 1
		E	UT2 - Undertorque 2
		F	Communication TEST Error
001Bh or 736h	Minor Fault Content 3 (Alarm)	0	OS-2 - CH2 Overspeed
		1	OH3 - Motor Overheat 1
		2	DNE - Drive not Ready
		3	PGO-2-S - PG CH2 Disconnect (Software Detection)
		4	PGO-2-H - PG CH2 Disconnect (Hardware Detection)
		5	BE4 - Brake Answer 1 (Start of Run)
		6	BE5 - Brake Answer 2 (End of Run)
		7	BE6 - Brake Slipping
		8	UL2 - Upper Limit 2
		9	LL2 - Lower Limit 2
		A	UL1 - Upper Limit 1
		B	LL1 - Lower Limit 1
		C	SLC - Slack Cable Detect
		D	MNT - Maintenance Required
		E	KLX - Klixon
		F	UL3 - Upper Limit 3
737h	Minor Fault Content 4 (Alarm)	0	BE8 - Brake Slipping (Load Catch)
		1 ~ F	Not Used (Future Alarms)

Monitor Registers (Read only) – Continued

REGISTER (in hex)	FUNCTION	BIT NO.	DESCRIPTION
0020h	Drive Status	0	Running
		1	Reverse Run
		2	Drive Operation Ready
		3	Drive Fault
		4	Data Setting Error
		5	Multi-Function Digital Output (Terminal M0 – M1)
		6	Multi-Function Digital Output (Terminal M2 – M4)
		7	Multi-Function Digital Output (Terminal M5 – M6)
		8 ~ F	Not Used
0021h	Major Fault Content	0	OC -Overcurrent, GF - Ground Fault
		1	OV - DC Bus Overvoltage
		2	OL2 - Inverter Overload
		3	OH1, OH2 Inverter Overheat
		4	RR - Braking Transistor Fault, RH - Internal Braking Resister Overheat
		5	PUF - Fuse Blown
		6	FbL - PID Feedback Loss
		7	External Fault (EF, EF0)
		8	CPF Hardware Fault
		9	OL1, OT1, OT2
		A	PGO-1-S, OS-1, DEV-1
		B	UV - DC Bus Undervoltage (No run command)
		C	UV1, UV2, UV3 Power Loss while running
		D	SPO - Output Phase, SPI - Input Phase
		E	CE - Memobus Communication Error
		F	OPR - Operator Connection Fault while running from operator
0022h	Data Link Status	0	Writing Data
		1 ~ 2	Not Used
		3	Parameter Upper/Lower Limit Fault
		4	Parameter Data Inconsistency Fault
		5 ~ F	Not Used
0023h	Frequency Reference		U1-01
0024h	Output Frequency		U1-02
0025h	Output Voltage		U1-06

Monitor Registers (Read only) – Continued

REGISTER (in hex)	FUNCTION	BIT NO.	DESCRIPTION
0026h	Output Current		U1-03
0027h	Output Power		U1-08
0028h	Torque Reference		U1-09
002Bh	Digital Input Status	0	Terminal 1 (Closed)
		1	Terminal 2 (Closed)
		2	Terminal 3 (Closed)
		3	Terminal 4 (Closed)
		4	Terminal 5 (Closed)
		5	Terminal 6 (Closed)
		6	Terminal 7 (Closed)
		7	Terminal 8 (Closed)
002Ch	Drive Status	0	During Run
		1	During Zero Speed
		2	During Speed Agree (Fixed: (Fref = Fout) or (Fref = Motor Speed)) (Width by L4-02)
		3	During Speed Agree (Programmable by L4-01, L4-02)
		4	Frequency Detection 1
		5	Frequency Detection 2
		6	Inverter Ready
		7	Undervoltage During Detection
		8	During Baseblock
		9	Frequency Reference Mode 1: Not from Comm.
		A	Run Command Mode 1: Not from Comm.
		B	Overtorque During Detection
		C	During Frequency Reference Loss
		D	During Fault Restart (Auto Reset)
		E	During Fault
		F	Memobus Timed Out
002Dh	Multi-Function Output Status	0	Multi-Function Output (Terminal M0, M1)
		1	Multi-Function Output (Terminal M2 ~ M4)
		2	Multi-Function Output (Terminal M5, M6)
		3 ~ F	Not Used
0031h	DC Bus Voltage		U1-07
0032h	Torque Reference		U1-09
0033h	Output Power		U1-08
038h	PID Setpoint		U1-24

Monitor Registers (Read only) – Continued

REGISTER (in hex)	FUNCTION	BIT NO.	DESCRIPTION
0039h	PID Input		U1-36
003Ah	PID Output		U1-37
003Bh	CPU Software Number		U1-28
003Ch	Flash Software Number		U1-114
003Dh	Comm. Error Description	0	CRC Error
		1	Data Length Error
		2	Not Used
		3	Parity Error
		4	Overrun Error
		5	Framing Error
		6	Timed Out
		7 ~ F	Not Used
003Eh	KVA Setting		Drive KW Rating
003Fh	Control Mode		Control Method

Drive Parameter Registers (U1-xx / Monitor Only)

REGISTER (in hex)	PARAMETER	PARAMETER FUNCTION	PARAMETER SETTING	BIT NO.	LIMITS / DESCRIPTION
040h	U1-01	Frequency Reference			Frequency Reference of drive (0.1 Hz) (1)
041h	U1-02	Output Frequency			Output Frequency of drive (0.1 Hz) (1)
042h	U1-03	Output Current			10V/Drive rated current (2)
043h	U1-04	Control Method	0		V/f Control
			1		V/f with PG Feedback
			2		Open Loop Vector
			3		Flux Vector
044h	U1-05	Motor Speed			Motor Speed (in 0.1 Hz)
045h	U1-06	Output Voltage			Output Voltage (in 0.1 V)
046h	U1-07	DC Bus Voltage			DC Bus Voltage (in 1 V)
047h	U1-08	Output Power			Output Power (in 0.1 kW)
048h	U1-09	Torque Reference			Torque Reference (in 0.1%)
049h	U1-10	Input Terminal Status		0	Input Terminal 1 closed
				1	Input Terminal 2 closed
				2	Input Terminal 3 closed
				3	Input Terminal 4 closed
				4	Input Terminal 5 closed
				5	Input Terminal 6 closed
				6	Input Terminal 7 closed
				7	Input Terminal 8 closed
04Ah	U1-11	Output Terminal Status		0	Control Circuit terminals M0, M1: "Closed"
				1	Control Circuit terminals M2 ~ M4: "Closed"
				2	Control Circuit terminals M5, M6: "Closed"
				3-6	Not Used
				7	Control Circuit terminals MA ~ MC: "Closed"

Notes:

(1) Scaling depends on the setting of o1-03.

(2) Display unit = 0.01A for models IMPULSE Series 3 2003 thru 2025 and 4001 thru 4011; display unit = 0.1A for models 2033 - 2300 and 4014 - 4605.

Drive Parameter Registers (U1-xx / Monitor Only) – Continued

REGISTER (in hex)	PARAMETER	PARAMETER FUNCTION	PARAMETER SETTING	BIT NO.	LIMITS / DESCRIPTION
04Bh	U1-12	Operation Status		0	Run
				1	Zero-Speed
				2	Reverse Run
				3	Reset Signal Input
				4	Speed Agree
				5	Drive Operation Ready
				6	Minor Fault
				7	Major Fault
04Ch	U1-13	Elapsed Time			Hours
04Dh	U1-14	Software No. (CPU ID No.)			Software version number
04Eh	U1-15	Control Circuit Term A1 Input Voltage			Input voltage signal at terminal A1 (+10V / +100.0% ~ -10V / -100.0%)
04Fh	U1-16	Control Circuit Term A2 Input Voltage			Input voltage or mAmp signal at terminal A2 (+10V / +100.0% ~ -10V / -100.0%) or (4mA / 0.0% ~ 20mA / 100.0%)
050h	U1-17	Control Circuit Term A3 Input Voltage			Input voltage signal at terminal A3 (+10V / +100.0% ~ -10V / -100.0%)
051h	U1-18	Motor Secondary Current (Iq)			Motor Secondary Current-Iq (0.1%)
052h	U1-19	Motor Exciting Current (Id)			Motor Rated Primary Current-Id (0.1%)
053h	U1-20	Output Frequency after Soft-start			Max. Output Frequency (0.1 Hz)
054h	U1-21	Automatic Speed Regulator (ASR) Input			ASR Input (0.01%)
055h	U1-22	Automatic Speed Regulator (ASR) Output			ASR Output (0.01%)
056h	U1-23	PG-Z2 CH2 Detection Speed			PG-Z2 CH2 Detection Speed (0.01%)
057h	U1-24	PID Feedback Amount			PID Feedback Amount (0.01%)
058h	U1-25	G5 IN4 Reference			Input value according to the setting of F3-01
059h	U1-26	Output Voltage Reference Vq			Output Voltage-Vq (0.1V)
05Ah	U1-27	Output Voltage Reference Vd			Output Voltage-Vd (0.1V)
05Bh	U1-28	Software No. CPU			processor version number
05Ch	U1-29	Load Weight			Weight Measurement
05Dh	U1-30	SS Delta Speed			Snap Shaft Speed Difference
05Eh					Not Used
05Fh	U1-32	ACR Output q Axis			ASR Output q Axis (0.1%)
060h	U1-33	ACR Output d Axis			ASR Output d Axis (0.1%)
061h	U1-34	OPE Detection			Parameter setting error
062h	U1-35	Zero Servo Motion Pulse			Pulse Count During Zero Servo
063h	U1-36	PID Input			PID Input (0.00%)
064h	U1-37	PID Output			PID Output (0.00%)
065h	U1-38	PID Setpoint			PID Setpoint (0.00%)

Drive Parameter Registers (U1-xx / Monitor Only) – Continued

REGISTER (in hex)	PARAMETER	PARAMETER FUNCTION	PARAMETER SETTING	BIT NO.	LIMITS / DESCRIPTION
066h	U1-39	Memobus Communication Error			
067h	U1-40	FAN Accumulated Operation Time			
068h	U1-41	Cooling Fin Temperature			
069h			Not Used		
06Ah			Not Used		
06Bh	U1-44	ASR Output			ASR Out No Filter
06Ch			Not Used		
06Dh			Not Used		
06Eh			Not Used		
06Fh			Not Used		
070h	U1-49	CPU Occupation Rate			Amount of CPU Resources Being Used
071h	U1-50	Hook Height			Calculated Height of Hook (0.00%) (Height Measurement)
072h	U1-51	Motor Revolution			Number of Motor Revolutions Since Upper Limit (UL2) (Height Measurement)
073h	U1-52	Maintenance Timer			Number of Hours Remaining Before Maintenance is Required
074h	U1-53	Inch 2 Count			Number of Pulses Encoder has Moved Since Inch 2 Command

Drive Parameter Registers (U2-xx / Fault Trace and U3-xx / Fault History)

REGISTER (in hex)	PARAMETER	PARAMETER FUNCTION	PARAMETER SETTING	BIT NO.	LIMITS / DESCRIPTION
080h	U2-01	Current Fault	Code of current fault (1)		
081h	U2-02	Last Fault	Code of second to current fault (1)		
082h	U2-03	Frequency Ref. at Fault	Frequency Reference at the time of the current fault (0.0 to 400.0 Hz)		
083h	U2-04	Output Frequency at Fault	Output Frequency at the time of current fault (0.0 to 400.0 Hz)		
084h	U2-05	Output Current at Fault	Output Current at the time of current fault (drive rating /8192)		
085h	U2-06	Motor Speed at Fault	Motor Speed at the time of current fault (in 0.1 Hz)		
086h	U2-07	Output Voltage at Fault	Output Voltage at the time of current fault (in 0.1 V)		
087h	U2-08	DC Bus Voltage at Fault	Output Voltage at the time of current fault (in 1 V)		
088h	U2-09	Output kWatts at Fault	Output Power at the time of current fault (in 0.1 kW)		
089h	U2-10	Torque Reference at Fault	Torque Reference at the time of current fault (in 0.1%)		
08Ah	U2-11	Input Terminal Status at Fault	0	Input Terminal 1 closed at time of fault	
			1	Input Terminal 2 closed at time of fault	
			2	Input Terminal 3 closed at time of fault	
			3	Input Terminal 4 closed at time of fault	
			4	Input Terminal 5 closed at time of fault	
			5	Input Terminal 6 closed at time of fault	
			6	Input Terminal 7 closed at time of fault	
			7	Input Terminal 8 closed at time of fault	
08Bh	U2-12	Output Terminal Status at Fault	0	Control Circuit terminals 9 & 10: "Closed"	
			1	Control Circuit terminals 25 & 27: "Closed"	
			2	Control Circuit terminals 26 & 27: "Closed"	
			3-6	not used	
			7	Control Circuit terminals 18 & 20: "Closed"	

Notes:

(1) List of Drive Error Codes can be found in chapter 6, Error Codes and Troubleshooting.

Drive Parameter Registers (U2-xx / Fault Trace and U3-xx / Fault History) – Continued

REGISTER (in hex)	PARAMETER	PARAMETER FUNCTION	PARAMETER SETTING	BIT NO.	LIMITS / DESCRIPTION
08Ch	U2-13	Drive Status at Fault		0	Running at the time of fault
				1	Zero-Speed at the time of fault
				2	Reverse Running at the time of fault
				3	Reset Signal Input at the time of fault
				4	Speed Agree at the time of fault
				5	Drive Operation Ready at the time of fault
				6	Minor Fault
				7	Major Fault
08Dh	U2-14	Elapsed Time at Fault		Elapsed Time at the time of fault (in hrs.)	
800h	U3-01	Last Fault	Code of the most recent fault (1)		
801h	U3-02	Fault Message 2	Code of the second to most recent fault (1)		
802h	U3-03	Fault Message 3	Code of the third to most recent fault (1)		
803h	U3-04	Fault Message 4	Code of the fourth to most recent fault (1)		
804h	U3-05	Elapsed Time 1	Elapsed Time at the most recent fault occurrence		
805h	U3-06	Elapsed Time 2	Elapsed Time at the second to most recent fault occurrence		
806h	U3-07	Elapsed Time 3	Elapsed Time at the third to most recent fault occurrence		
807h	U3-08	Elapsed Time 4	Elapsed Time at the fourth to most recent fault occurrence		
808h	U3-09	Fault Message 5	Code of the fifth to most recent fault (1)		
809h	U3-10	Fault Message 6	Code of the sixth to most recent fault (1)		
80Ah	U3-11	Fault Message 7	Code of the seventh to most recent fault (1)		
80Bh	U3-12	Fault Message 8	Code of the eighth to most recent fault (1)		
80Ch	U3-13	Fault Message 9	Code of the ninth to most recent fault (1)		
80Dh	U3-14	Fault Message 10	Code of the tenth to most recent fault (1)		
80Eh	U3-15	Elapsed Time 5	Elapsed Time at the fifth to most recent fault occurrence		
80Fh	U3-16	Elapsed Time 6	Elapsed Time at the sixth to most recent fault occurrence		
810h	U3-17	Elapsed Time 7	Elapsed Time at the seventh to most recent fault occurrence		
811h	U3-18	Elapsed Time 8	Elapsed Time at the eighth to most recent fault occurrence		
812h	U3-19	Elapsed Time 9	Elapsed Time at the ninth to most recent fault occurrence		
813h	U3-20	Elapsed Time 10	Elapsed Time at the tenth to most recent fault occurrence		
814h	U3-21	Accumulated Operations	Accumulated Operations		
815h	U3-22	U3-21 Rollover	Increments each time U3-21 reaches 65535. U3-21 is set to 0		
816h	U3-23	OL / LC Count	OverLoad / Load Check Count		

Notes: (1) List of Drive Error Codes can be found in chapter 6, Error Codes and Troubleshooting.

Drive Parameter Registers (Read/Write)

REGISTER (in hex)	PARAMETER	PARAMETER FUNCTION	PARAMETER SETTING	LIMITS / DESCRIPTION	INITIAL VALUE
100h	A1-00	Language Selection	0	English	0
			1	French	
			2	Spanish	
101h	A1-01	Parameter Access Level	0	Operation Only	2
			1	User Program	
			2	Advanced	
			3	Factory	
102h	A1-02	Control Method Selection	0	V/f Control	2
			1	V/f Control w/ PG (Factory Access Only)	
			2	Open Loop Vector	
			3	Flux Vector	
103h	A1-03	Motion Select	0	Traverse	1
			1	Standard Hoist	
			2	No-Load Brake Hoist	
			3	Bucket Hoist	
104h	A1-04	Speed Reference	0	2-Spd Multi-Step	6
			1	3-Spd Multi-Step	
			2	5-Spd Multi-Step	
			3	2-Step Infinitely Variable	
			4	3-Step Infinitely Variable	
			5	Uni-Polar Analog	
			6	Bi-Polar Analog	
			7	G5IN4 Option Card	
			8	Serial Opt Card	
105h	A1-05	Initialize Parameters	0000	No Initialize	0
			1110	User Initialize	
			2220	2-wire Initialize	
106h	A1-06	User Password 1	0000 ~ 9999		0
108h	A1-07	Factory Password 2	0000 ~ 9999		0
10Ah Through 129h	A2-01 ~ A2-32	User Selected Parameter 1 Through User Selected Parameter 32	Setting B1-01 ~ O4-02		0

Drive Parameter Registers (Read/Write) – continued

REGISTER (in hex)	PARAMETER	PARAMETER FUNCTION	PARAMETER SETTING	LIMITS / DESCRIPTION	INITIAL VALUE
180h	B1-01	Frequency Reference 1		0.00 to 400.00 Hz (1)	15.00
181h	B1-02	Frequency Reference 2		0.00 to 400.00 Hz (1)	30.00
182h	B1-03	Frequency Reference 3		0.00 to 400.00 Hz (1)	60.00
183h	B1-04	Frequency Reference 4		0.00 to 400.00 Hz (1)	45.00
184h	B1-05	Frequency Reference 5		0.00 to 400.00 Hz (1)	60.00
185h	B1-06	Frequency Reference 6		0.00 to 400.00 Hz (1)	0.00
186h	B1-07	Frequency Reference 7		0.00 to 400.00 Hz (1)	0.00
187h	B1-08	Frequency Reference 8		0.00 to 400.00 Hz (1)	0.00
188h	B1-09	Frequency Reference 9		0.00 to 400.00 Hz (1)	0.00
189h	B1-10	Frequency Reference 10		0.00 to 400.00 Hz (1)	0.00
18Ah	B1-11	Frequency Reference 11		0.00 to 400.00 Hz (1)	0.00
18Bh	B1-12	Frequency Reference 12		0.00 to 400.00 Hz (1)	0.00
18Ch	B1-13	Frequency Reference 13		0.00 to 400.00 Hz (1)	0.00
18Dh	B1-14	Frequency Reference 14		0.00 to 400.00 Hz (1)	0.00
18Eh	B1-15	Frequency Reference 15		0.00 to 400.00 Hz (1)	0.00
18Fh	B1-16	Frequency Reference 16		0.00 to 400.00 Hz (1)	0.00
190h	B1-17	Jog Frequency Reference		0.00 to 400.00 Hz (1)	6.00
191h	B1-18	Reference Priority ¹	0	Digital Reference Only	0
			1	Analog Reference Only	
			2	Higher Reference Select	
192h	B2-01	Frequency Reference Upper Limit		0.0 to 110.0%	100.0
193h	B2-02	Frequency Reference Lower Limit		0.0 to 110.0%	0.0
194h	B2-03	Master Speed Ref Lower Limit		0.0 to 110.0%	2
195h	B2-04	Alternate Upper Limit		0.0 to 110.0%	100
196h	B3-01	Reference Selection	0	Digital Operator	1
			1	Terminal	
			2	Serial Communication	
			3	Option PCB	
197h	B3-02	Operation Method Selection	0	Digital Operator	1
			1	Terminal	
			2	Serial Communication	
			3	Option PCB	

Drive Parameter Registers (Read/Write) – continued

REGISTER (in hex)	PARAMETER	PARAMETER FUNCTION	PARAMETER SETTING	LIMITS / DESCRIPTION	INITIAL VALUE
198h	B3-03	Stopping Method Selection	0	Ramp to Stop	Determined by A1-03 (Motion)
			1	Coast to Stop	
			2	DC Injection to Stop	
			3	Coast with Timer	
			4	Ramp with Timer	
			5	Hoist 2 Stop	
			6	No Load Brake	
29Ah	B3-04	Motor Rotation	0	Normal Rotation	0
			1	Exchange Phases	
199h	B3-05	Zero Speed Operation (level determined by E1-09)	0	Run at Frequency Reference	0
			1	Stop	
			2	Run at Min. Frequency (E1-09)	
			3	Run at Zero Speed	
19Ah	B3-06	Logic Input Scan Rate	0	2ms - 2 scans	1
			1	5ms - 2 scans	
19Bh	B3-07	Local / Remote RUN Selection	0	Cycle External Run	0
			1	Accept External Run	
19Ch	B3-08	Run Command Selection @ Program Mode	0	Disabled	0
			1	Enabled	
19Eh	B3-10	Allow Run @ Power Up	0	Disabled	0
			1	Enabled	
19Fh	B4-01	Frequency reference Hold Function	0	Disabled: Operates at Zero when restarting	0
			1	Enabled: Operates at previously held frequency	
1A0h	B4-02	Trim Control Level	0 to 100%		10
1A1h	B5-01	Acceleration Time 1	0.0 to 25.5 seconds		5.0
1A2h	B5-02	Deceleration Time 1	0.0 to 25.5 seconds		3.0
1A3h	B5-03	Acceleration Time 2	0.0 to 6000.0 seconds		2.0
1A4h	B5-04	Deceleration Time 2	0.0 to 6000.0 seconds		2.0
1A5h	B5-05	Acceleration Time N Chg	0.0 to 25.5 seconds		2.0
1A6h	B5-06	Deceleration Time N Chg	0.0 to 25.5 seconds		2.0
1A8h	B5-08	Fast Stop Time	0.0 to 25.5 seconds		0.5
1A9h	B5-09	Accel / Decel Time Setting Unit	0	0.01 seconds	1

			1	0.1 seconds	
--	--	--	---	-------------	--

Drive Parameter Registers (Read/Write) – continued

REGISTER (in hex)	PARAMETER	PARAMETER FUNCTION	PARAMETER SETTING	LIMITS / DESCRIPTION	INITIAL VALUE
1AAh	B5-10	Accel / Decel Time Switching Freq.		0.0 to 400.0 Hz	60.00
1ACh	B5-12	Acceleration Time 3		0.0 to 6000.0 seconds	3.0
1ADh	B5-13	Deceleration Time 3		0.0 to 6000.0 seconds	3.0
1AEh	B5-14	Acceleration Time 4		0.0 to 6000.0 seconds	3.0
1AFh	B5-15	Deceleration Time 4		0.0 to 6000.0 seconds	3.0
1B0h	B6-01	Speed Search @ Start	0	Disabled	2
			1	Enabled: Speed Estimation Type	
			2	Disabled	
			3	Enabled: Current Detection Type	
1B1h	B6-02	Speed Search Operation Current		0.0 to 200.0%	120
1B2h	B6-03	Speed Search Deceleration Time		0.1 to 10.0 seconds	2.0
1B4h	B6-05	Search Delay Time		0.0 to 20.0 seconds	0.2
1B9h	B6-10	Speed Detect Comp Gain		1.00 to 1.50	1.10
29Dh	B6-14	Bidirectional Search	0	Disabled: Drive uses frequency reference det	1
			1	Enabled: Drive uses detected direction	
1BCh	B8-01	Jump Frequency 1		0.0 to 400.0 Hz	0.0
1BDh	B8-02	Jump Frequency 2		0.0 to 400.0 Hz	0.0
1BEh	B8-03	Jump Frequency 3		0.0 to 400.0 Hz	0.0
1BFh	B8-04	Jump Bandwidth		0.0 to 20.0 Hz	1.0
1C4h	C1-01	Quick Stop 0/1	0	Disabled	0
			1	Enabled	
1C5h	C1-02	Quick Stop Time		0.0 to 25.5 seconds	1.0
1C6h	C1-03	Plug Reverse 0/1	0	Disabled	0
			1	Enabled	
1C7h	C1-04	Plug Reverse Decel Time		0.0 to 25.5 seconds	2.0
1C8h	C1-05	Plug Reverse Accel Time		0.0 to 25.5 seconds	2.0
1C9h	C2-01	Micro Speed Gain 1		0.00 to 2.55	1.0
1CAh	C2-02	Micro Speed Gain 2		0.00 to 2.55	1.0
1CBh	C3-01	Upper Limit 1 Speed		0.00 to 400.00 Hz	6.00
1CCh	C3-02	Upper Limit 1 Decel Time		0.0 to 25.5 sec	1.0
1CDh	C3-03	Upper Limit 2 Stop Time		0.0 to 25.5 sec	0.5

Drive Parameter Registers (Read/Write) – continued

REGISTER (in hex)	PARAMETER	PARAMETER FUNCTION	PARAMETER SETTING	LIMITS / DESCRIPTION	INITIAL VALUE
1CEh	C3-04	Lower Limit 1 Speed		0.00 to 400.00 Hz	6.00
1CFh	C3-05	Lower Limit 1 Decel Time		0.0 to 25.5 sec	1.0
1D0h	C3-06	Lower Limit 2 Stop Time		0.0 to 25.5 sec	1.0
1D1h	C3-07	Limit Stop Method	0	Decel to Stop	2
			1	BB to Stop	
			2	Use B3-03 Method	
1D2h	C3-08	UL3 Stop Method	0	Decel/Alarm(No further raise allowed)	4
			1	Coast/Alarm (No further raise allowed)	
			2	Use B3-03/Alarm (No further raise allowed)	
			3	Decel/Fault	
			4	Coast/Fault	
			5	Use B3-03/Fault	
1D3h	C3-09	Phantom Stop Met	0	Decel To stop	1
			1	Coast to Stop	
			2	Use B3-03 Method	
600h	C3-10	Load Share Limit	0	Disabled	0
			1	Enabled	
1D4h	C4-01	Load Float Time 2		0 to 255 Sec	10
1D5h	C4-02	Load Float Gain		0 to 100	10/20
1D6h	C4-03	Load Float Count		0 to 16383	10
1D7h	C5-01	Load Check 0 / 1	0	Disabled	0
			1	Enabled	
1D8h	C5-02	Load Check Alarm Action	0	Alarm Only	1
			1	Decel to Stop	
			2	Coast to Stop	
			3	Fault Stop	
			4	Use B3-03 Method – Can lower only (Alarm)	
1D9h	C5-03	Minimum Torque Reference		0 to 100%	60
1DAh	C5-04	Look Speed 1		0 to 400 Hz	6
1DBh	C5-05	I Ref for LS 1 (V/F or OLV)		1 to 300 % IRC	160
1DDh	C5-07	Look Speed 2		0 to 400 Hz	20
1DEh	C5-08	I Ref for LS 2 (V/F or OLV)		1 to 300 % IRC	160
1DFh	C5-09	Look Speed 3		0 to 400 Hz	40
1E0h	C5-10	I Ref for LS 3 (V/F or OLV)		1 to 300 % IRC	160

Drive Parameter Registers (Read/Write) – continued

REGISTER (in hex)	PARAMETER	PARAMETER FUNCTION	PARAMETER SETTING	LIMITS / DESCRIPTION	INITIAL VALUE
1E1h	C5-11	I Ref for > LS 3	1 to 300 %	160	
1E2h	C5-12	Load Check Setting Time	0.00 to 2.55 sec	1.00	
1E3h	C5-13	Load Check Test Time	0.00 to 2.55 sec	0.25	
1E4h	C5-14	Load Check Alarm Speed	0.0 to 30.0 Hz	6.0	
1E5h	C6-01	Ultra / Swift Lift 0 / 1	0	Disabled	0
			1	Enabled Automatic	
			2	Enabled by MFI	
1E6h	C6-02	Ultra / Swift Lift Forward Speed		0 to 400 Hz	60
1E7h	C6-03	Ultra / Swift Lift Reverse Speed		0 to 400 Hz	60
1E8h	C6-04	Ultra / Swift Lift Forward Torque		0 to 100 %	50
1E9h	C6-05	Ultra / Swift Lift Reverse Torque		0 to 100 %	30
1EAh	C6-06	Ultra / Swift Lift Enabling Speed		0.0 to 400.0 Hz	59.0
1EBh	C6-07	Ultra / Swift Lift Delay Time		0.0 to 25.5 sec	2.0
1ECh	C6-08	SFS Acc Gain		0.1 to 9.9	1.0
286h	C6-09	Normal OS Level		40.0 to 400.0 Hz	60.0
1EDh	C7-01	Forward Torque Limit		0 to 300%	150
1EEh	C7-02	Reverse Torque Limit		0 to 300%	150
1EFh	C7-03	Forward Regenerative Torque Limit		0 to 300%	180
1F0h	C7-04	Reverse Regenerative Torque Limit		0 to 300%	180
1F1h	C7-05	Torque Limit Gain MFI		0 to 2.55	1.25
1F3h	C8-01	Torque Compensation Time		0.00 to 2.55 Sec	1.00 / 2.00
1F4h	C8-02	IFB OK Time		0.00 to 2.55 Sec	1.00 / 2.00
1F5h	C8-03	Minimum Brake Release Torque		0 to 300 %	10/100
1F6h	C8-04	Roll Back Timer / BE4 Timer		0.00 to 2.55 Sec	0.30
1F7h	C8-05	Roll Back Count		0 to 16536 Pulses	800
1F8h	C8-06	BE3 / Alternate Torque Timer		0.00 to 2.55 Sec	0.30
1F9h	C8-07	BE3 Detection Count		0 to 16536 Pulses	25
1FAh	C8-08	Alternate Reverse Torque Limit		0 to 300 %	25
1FBh	C8-09	Zero Speed Level		0.0 to 10.0 Hz	1
1FCh	C8-10	Load Float Time		0 to 255 Sec	10
1FDh	C8-11	Brake Set Delay Time		0.00 to 25.5 Sec	0.7
1FEh	C8-12	BE6 Detect Timer		0.00 to 25.5 Sec	5.0
1FFh	C8-13	BE6 Max Count		0 to 16536 Pulses	250

Drive Parameter Registers (Read/Write) – continued

REGISTER (in hex)	PARAMETER	PARAMETER FUNCTION	PARAMETER SETTING		LIMITS / DESCRIPTION
200h	C8-14	Brake Hold Speed	B2-02 + 0.1 to 25.5 %		5.0
201h	C8-15	Load Float Extension timer	0 to 255 Sec		10
202h	C8-16	Initial Brake Release Torque	0 to 300 %		100
203h	C8-17	BE6 Up Speed Limit	0.00 to 400.00 Hz		6.00
205h	C8-19	Brake Test Torque	0 to 300%		125
206h	C8-20	Brake Test Speed	0 to 10Hz		6
207h	C8-21	Height Measure	0 to 65535		250
601h	C8-22	Brake Slip Detect	0	Disabled	0
			1	Enabled	
602h	C8-23	Brake Slip Detect Speed	0.0 to 10.0 Hz		1.0
208h	C9-01	G5IN4 Option Enable	0	Disabled	0
			1	Enabled	
209h	C9-02	G5IN4 Option Setup	0000 to FFFF		0
20Ah	C10-01	Load Weight 0 / 1	0	Disabled	0
			1	Enabled at C5-04	
			2	Enabled by MFI	
			3	Both Auto & MFI	
			4	Analog Input (Load Cell) Data "16"	
20Bh	C10-02	Torque Primary Delay	0 to 1000 ms		200
20Ch	C10-03	Load Weight Display	0	Hold Display	0
			1	Hold Display for 3 Seconds	
20Dh	C10-04	Load Weight Conversion	00000 to 39999		0
20Eh	C10-05	Full Load Torque	0.0 to 200.0 %		100.0
20Fh	C10-06	No Load Torque	0.0 to 200.0 %		20.0
210h	C10-07	Unit Displayed	0	Tons	0
			1	Pounds	
			2	Kilograms	
			3	Metric Tons	
			4	Percent load	
211h	C10-08	Weight Limit Output	0.0 to 200.0%		125.0%
212h	C11-01	Slack Cable 0 / 1	0	Disabled	0
			1	Enabled	

Drive Parameter Registers (Read/Write) – continued

REGISTER (in hex)	PARAMETER	PARAMETER FUNCTION	PARAMETER SETTING	LIMITS / DESCRIPTION	INITIAL VALUE
213h	C11-02	Action at Slack Cable	0	No Action	2
			1	No Action / C3-04	
			2	Decel / C3-04	
			3	Decel / No Operation	
			4	Decel to Stop / C3-04	
			5	Decel to Stop / No Operation	
214h	C11-03	Slack Cable Detect Torque		0 to 100 %	30
215h	C11-04	Slack Cable Detect Speed 1		0 to 150 Hz	2
216h	C11-05	Slack Cable Delay Time 1		0.00 to 2.55 Sec	0.50
217h	C11-06	Slack Cable Detect Speed 2		0 to 150 Hz	60
218h	C11-07	Slack Cable Delay Time 2		0.00 to 2.55 Sec	0.10
219H	C11-08	Snap Shaft Detection	0	Disabled	0
			1	Enabled	
21Ah	C11-09	Drive Train Discontinue (Action @ Snap Shaft)	0	Brake / Fault Out	0
			1	Alarm Only	
21Bh	C11-10	SS Delta Speed		0.0 to 400.0 Hz	1.0
21Ch	C11-11	SS Delay Time		0 to 2000 mSec	250
21Dh	C11-12	Gear Ratio Numerator		1 to 65535	10000
21Eh	C11-13	Gear Ratio Denominator		1 to 65535	10000
21Fh	C12-01	Brake Jog Delay		0.0 to 100.0 Sec	0.0
220h	C12-02	Brake Run Delay		0.0 to 100.0 Sec	0.0
221h	C12-03	Delay-ON Timer		0.0 to 3000.0 Sec	0.0
222h	C12-04	Delay-OFF Timer		0.0 to 3000 Sec	0.0
223h	C12-05	Maintenance Timer		0 to 32767 Hour	0
224h	C12-06	Maintenance Gain		0.00 to 1.00	0.50
225h	C13-01	Inch Run Time		0.00 to 2.55 Sec	1.00
226h	C13-02	Inch Repeat Delay Time		0.00 to 2.55 Sec	1.00
227h	C13-03	Index Run Reference		0.01 to 60.00 Hz	0.10
228h	C13-04	Index Revolutions		0 to 65535 Revs	0
229h	C13-05	Index Count		0 to 65535 PLS	100
22Ah	C13-06	Index Repeat Delay		0.00 to 60.00 Sec	0.00
22Bh	C13-07	Index Complete		0 to 32767	10
288h	C13-08	Index Zero Servo Gain		0 to 100	10

Drive Parameter Registers (Read/Write) – continued

REGISTER (in hex)	PARAMETER	PARAMETER FUNCTION	PARAMETER SETTING	LIMITS / DESCRIPTION	INITIAL VALUE
289h	C13-09	Index ASR P Gain		0.00 to 300.00	30.00
28Ah	C13-10	Index ASR I Time		0.000 to 10.000 Sec	0.20
28Bh	C13-11	Index Gain		0.0 to 20.0	5.0
23Bh	D1-01	DC Injection Start Frequency		0.0 to 10.0 Hz	0.5
23Ch	D1-02	DC Injection Current		0 - 100%	50
23Dh	D1-03	DC Injection Time at Start		0.00 - 10.00 seconds	0.00
23Eh	D1-04	DC Injection Time at Stop		0.00 - 10.00 seconds	0.05
243h	D2-01	Slip Compensation Gain		0.0 to 2.5	0.0 / 1.0
244h	D2-02	Slip Comp Primary Delay Time		0 to 10000 msec.	200 / 2000
245h	D2-03	Slip Compensation Limit		0 to 250%	200
246h	D2-04	Slip Compensation Selection during Regeneration	0	Disabled	0
			1	Enabled	
247h	D2-05	V/f Slip Comp Select	0	Disabled	0
			1	Enabled	
248h	D2-06	Output V Limit Select	0	Magnetek Flux is calculated by output frequency after compensation	0
			1	Magnetek Flux is calculated by output frequency before compensation	
249h	D3-01	Torque Compensation Gain		0.00 to 2.50	1.00
24Ah	D3-02	Torque Compensation Time		0.00 to 10000 ms	20 / 200
24Bh	D3-03	Torque Compensation for Forward		0.0 to 200.0%	0.0
24Ch	D3-04	Torque Compensation for Reverse		-200.0 to 0.0%	0.0
24Dh	D3-05	Torque Compensation Time Const @ Start		0 to 200 ms	10
24Fh	D4-01	ASR Proportional Gain 1		0.00 to 300.00	30.00 / 0.30
250h	D4-02	ASR Integral Time 1		0.000 to 10.000 seconds	0.500 / 0.20
251h	D4-03	ASR Proportional Gain 2		0.00 to 300.00	30.00
252h	D4-04	ASR Integral Time 2		0.000 to 10.000 seconds	0.100 / 0.050
253h	D4-05	ASR Limit		0.0 to 20.0%	5.0
254h	D4-06	ASR Primary Delay Time		0.000 TO 0.500 seconds	0.004
255h	D4-07	ASR Gain Switching Frequency		0.0 to 400.0 Hz	0.0
256h	D4-08	ASR Integral Limit		0 to 400 %	400
257h	D5-01	Torque Control	0	Speed Control (Controlled by D4-01 ~ 07)	0
			1	Torque Control	

Drive Parameter Registers (Read/Write) – continued

REGISTER (in hex)	PARAMETER	PARAMETER FUNCTION	PARAMETER SETTING	LIMITS / DESCRIPTION	INITIAL VALUE
258h	D5-02	Torque Ref Filter		0 to 1000 ms	0
259h	D5-03	Speed Limit Select	1	Limited by Frequency Reference (B3-01)	2
			2	Programming Setting (D5-04)	
25Ah	D5-04	Speed Limit Value		-120 to +120%	100
25Bh	D5-05	Speed Limit Bias		0 to 120%	0
25Ch	D5-06	Ref Hold Time		0 to 1000 ms	0
25Dh	D6-01	Droop Control Gain		0.0 to 100.0 ms	0.0
25Eh	D6-02	Droop Control Delay Time		0.03 to 2.00 seconds	0.05
270h	D8-01	Dwell Frequency at Start		0.0 to 400.0 Hz	0.0
271h	D8-02	Dwell Time at Start		0.0 to 10.0 seconds	0.0
272h	D8-03	Dwell Frequency at Stop		0.0 to 400.0 Hz	0.0
273h	D8-04	Dwell Time at Stop		0.0 to 10.0 seconds	0.0
274h	D9-01	S-curve Characteristic at Accel Start		0.0 to 2.50 seconds	0.20
275h	D9-02	S-curve Characteristic at Accel End		0.0 to 2.50 seconds	0.20
276h	D9-03	S-curve Characteristic at Decel Start		0.0 to 2.50 seconds	0.20
277h	D9-04	S-curve Characteristic at Decel End		0.0 to 2.50 seconds	0.20
282h	D11-01	Hunting Prevention Select	0	Disabled	1
			1	Enabled	
283h	D11-02	Hunting Prevention Gain		0.00 to 2.50	1.00

Drive Parameter Registers (Read/Write) – continued

REGISTER (in hex)	PARAMETER	PARAMETER FUNCTION	PARAMETER SETTING	LIMITS / DESCRIPTION	INITIAL VALUE
300h	E1-01	Input Voltage Setting		155 to 255V (230V unit) 310 to 510V (460V unit)	230 460
302h	E1-03	V/f Pattern Selection	0 to E	15 preset V/f patterns	(1)
			F	Custom Pattern (using E1-04 to E1-10)	
303h	E1-04	Maximum Output Frequency		40.0 to 300.0 Hz CT 40.0 to 400.0 Hz VT	60.0
304h	E1-05	Maximum Voltage		0.0 to 255.0V (230V unit) 0.0 to 510.0V (460V unit)	230.0 460.0
305h	E1-06	Base Frequency		0.0 to 400.0 Hz	60.0
306h	E1-07	Mid. Output Frequency A		0.0 to 400.0 Hz	(1)
307h	E1-08	Mid Output Voltage A		0.0 to 255.0V (230V unit) 0.0 to 510.0V (460V unit)	(1)
308h	E1-09	Min. Output Frequency		0.0 to 400.0 Hz	(1)
309h	E1-10	Min. Output Voltage		0.0 to 255.0V (230V unit) 0.0 to 510.0V (460V unit)	(1)
30Ah	E1-11	Mid Frequency B		0.0 to 400.0 Hz	0.0
30Bh	E1-12	Mid Voltage B		0.0 to 255.0 VAC	0.0
30Ch	E1-13	Base Voltage		0.0 to 255.0 VAC	0.0
30Dh		Reserved			
30Eh	E2-01	Motor Rated Current		0.32 to 6.40 A	(2)
30Fh	E2-02	Motor Rated Slip		0.00 to 20.00 Hz	(2)
310h	E2-03	Motor No-Load Current		0.00 to 1.89 Amps	(2)
311h	E2-04	Number of Motor Poles		2 to 48 poles	4
312h	E2-05	Motor Terminal Resistance		0.000 to 65.000 Ohms	(2)
313h	E2-06	Motor Leakage Inductance		0.0 to 40.0%	(2)
314h	E2-07	Motor Iron-core Saturation Coefficient 1		0.00 to 0.50	.50
315h	E2-08	Motor Iron-core Saturation Coefficient 2		E2-07 to 0.75	0.75
316h	E2-09	Motor Mechanical Loss		0.0 to 10.0%	0.0

Notes (for this page only):

(1) Initial Value differs depending on the control method (A1-02).

(2) Values differ depending on the drive capacity.

Drive Parameter Registers (Read/Write) – continued

REGISTER (in hex)	PARAMETER	PARAMETER FUNCTION	PARAMETER SETTING	LIMITS / DESCRIPTION	INITIAL VALUE
317h	E2-10	Tcomp Iron Loss		0 ~ 65535 W	(1)
318h	E2-11	Rated Horsepower		0.00 ~ 650.00	(1)
380h	F1-01	Encoder (PG) Constant		0 to 60000 ppr	1024
381h	F1-02	Operation Selection at PG Open Circuit	0	Ramp to stop	1
			1	Coast to stop	
			2	Fast-stop	
			3	Alarm only	
382h	F1-03	Operation Selection at Overspeed	0	Ramp to stop	1
			1	Coast to stop	
			2	Fast-stop	
			3	Alarm only	
383h	F1-04	Operation Selection at Speed Deviation	0	@Speed Agree-Ramp to stop(B5-02)	1
			1	@Speed Agree-Coast to stop	
			2	@Speed Agree_Fast-stop(B5-08)	
			3	@Speed Agree-Alarm only	
			4	@Run-Decel(B5-02)	
			5	@Run-Coast to Stop	
			6	@Run-Fast Stop(B5-08)	
			7	@Run-Alarm Only	
384h	F1-05	PG Rotation	0	FWD:Counter-clockwise	0
			1	FWD:Clockwise	
385h	F1-06	PG Division Rate (PG Pulse Monitor)	1 to 132 (effective only with PG-B2 control board)		1
386h	F1-07	Integral Value during Accel/Decel Selection	0	Disabled	0
			1	Enabled	
387h	F1-08	Overspeed Detection Level		0 to 120%	115
388h	F1-09	Overspeed Detection Delay Time		0.0 to 2.0 seconds	0.0
389h	F1-10	Excessive Speed Deviation Detection Level		0 to 50%	10
38Ah	F1-11	Excessive Speed Deviation Detection Delay Time		0.0 to 10.0 seconds	0.3

Notes (for this page only):

(1) Initial Value differs depending on the control method (A1-02).

Drive Parameter Registers (Read/Write) – continued

REGISTER (in hex)	PARAMETER	PARAMETER FUNCTION	PARAMETER SETTING	LIMITS / DESCRIPTION	INITIAL VALUE
38Bh	F1-12	Number of PG Gear Teeth 1		0 to 1000	0
38Ch	F1-13	Number of PG Gear Teeth 2		0 to 1000	0
38Dh	F1-14	PG-O Ch1 Software Detection Time		0 ~ 10.0 Sec	0.5
38Fh	F1-16	PG CH2 PPR		1 to 60000 PPR	1024
390h	F1-17	PG CH2 Rotation	0	0: FWD = C.C.W	0
			1	1: FWD = C.W.	
391h	F1-18	PG-O Ch2 Software Detection Time		0 ~ 10 Sec	0.5
392h	F1-19	PG-Z2 Output Select	0	Select by MFI 41 (Motor 2 Select)	2
			1	Channel 1	
			2	Channel 2	
			3	Select by MFI 64	
393h	F1-20	PGO-1-H	0	Disabled	1
			1	Enabled	
394h	F1-21	PGO-2-H	0	Disabled	0
			1	Enabled	
395h	F1-22	PG-Z2 Input Sel	0	Motor 1 = CH1 (Motor 2 = CH2)	0
			1	Motor 1 = CH2 (Motor 2 = CH1)	
396h	F2-01	AI-14 Bi-polar or Uni-polar Input Selection	0	3-channel Individual	0
			1	3-channel Addition	
397h	F3-01	DI-16 Digital Input Option	0	BCD 1%	0
			1	BCD 0.1%	
			2	BCD 0.01%	
			3	BCD 1 Hz	
			4	BCD 0.1 Hz	
			5	BCD 0.01 Hz	
			6	BCD (5DG) 0.01 Hz	
			7	Binary	
398h	F4-01	AO-08/AO-12 Channel 1 Monitor Select.		1 to 50	2
399h	F4-02	AO-08/AO-12 Channel 1 Gain		0.00 to 1000.0%	100.0
39Ah	F4-03	AO-08/AO-12 Channel 2 Monitor Select.		1 to 50	3
39Bh	F4-04	AO-08/AO-12 Channel 2 Gain		0.00 to 1000.0%	100.0
39Ch	F4-05	CH1 AO Bias		-110.0 ~ 110.0%	0.0

Drive Parameter Registers (Read/Write) – continued

REGISTER (in hex)	PARAMETER	PARAMETER FUNCTION	PARAMETER SETTING	LIMITS / DESCRIPTION	INITIAL VALUE
39Dh	F4-06	CH2 AO Bias		-110.0 ~ 110.0%	0.0
39Eh	F4-07	Analog Output Signal Level CH1	0	0 ~ 10VDC	0
			1	-10 ~ +10VDC	
39Fh	F4-08	Analog Output Signal Level CH2	0	0 ~ 10VDC	0
3A0h	F5-01	DO-02 Channel 1 Output Selection		00 to FF	F
3A1h	F5-02	DO-02 Channel 2 Output Selection		00 to FF	F
3A2h	F5-03	DO-02 Channel 3 Output Selection		00 to FF	F
3A3h	F5-04	DO-02 Channel 4 Output Selection		00 to FF	F
3A4h	F5-05	DO-02 Channel 5 Output Selection		00 to FF	F
3A5h	F5-06	DO-02 Channel 6 Output Selection		00 to FF	F
3A6h	F5-07	DO-02 Channel 7 Output Selection		00 to FF	F
3A7h	F5-08	DO-02 Channel 8 Output Selection		00 to FF	F
3A8h	F5-09	DO-08 Output Mode Selection	0	8-channel Individual	0
			1	Binary Output	
			2	8CH Sel-Outputs according to F5-01 ~ 08	
			3	Serial Com Output – Serial Communication	
3A9h	F6-01	Communication Error Detection Operation Selection	0	Deceleration To Stop (B5-02)	1
			1	Coast To Stop	
			2	Fast Stop (B5-08)	
			3	Use B3-03 Method	
			4	Alarm Only (Operation Continues)	
3AAh	F6-02	EFO Detection	0	Always Detected	0
			1	Detected Only During Run	

Drive Parameter Registers (Read/Write) – continued

REGISTER (in hex)	PARAMETER	PARAMETER FUNCTION	PARAMETER SETTING	LIMITS / DESCRIPTION	INITIAL VALUE
3ABh	F6-03	EFO Fault Action	0	Deceleration To Stop (B5-02)	1
			1	Coast To Stop	
			2	Fast Stop (B5-08)	
			3	Use B3-03 Method	
			4	Alarm Only (Operation Continues)	
3ADh	F6-05	Current Monitor Display Unit Selection	0	Amp Display	0
			1	100%/8192	
3AEh	F6-06	Torque Reference/Torque Limit	0	Disabled-Torque Ref/Limit From Communication is Disabled	0
			1	Enabled – Torque Reference/Limit From Communication is Enabled	
400h	H1-01	Multi-function Input (terminal 3)	0 to 6Dh		0
401h	H1-02	Multi-function Input (terminal 4)	0 to 6D h		1
402h	H1-03	Multi-function Input (terminal 5)	0 to 6D h		F
403h	H1-04	Multi-function Input (terminal 6)	0 to 6D h		F
404h	H1-05	Multi-function Input (terminal 7)	0 to 6D h		F
405h	H1-06	Multi-function Input (terminal 8)	0 to 6D h		F
40Bh	H2-01	Multi-function Output (term. M1 - M2)	0 to FF h		0
40Ch	H2-02	Multi-function Output (term. M3 – M4)	0 to FF h		0
40Dh	H2-03	Multi-function Output (term. M5 – M6)	0 to FFh		7F
410h	H3-01	Terminal A1 Signal Voltage	0	0 to 10 V DC	0
			1	-10 to +10 V DC	
411h	H3-02	Terminal A1 Gain	0.0 to 1000.0%		100.0
412h	H3-03	Terminal A1 Signal Bias	-100.0 to +100.0%		0.0
413h	H3-04	Terminal A3 Signal Voltage	0	0 to 10 V DC	0
			1	-10 to +10 V DC	
414h	H3-05	Multi-function Analog Input Term A3 Select	0 to 1F		1F
415h	H3-06	Multi-function Analog Input Term A3 Gain	0.0 to 1000.0%		100.0
416h	H3-07	Multi-function Analog Input Term A3 Bias	-100.0 to +100.0%		0.0
417h	H3-08	Terminal A2 Signal Voltage	0	0 to 10 V DC	2
			1	-10 to +10 V DC	
			2	4 to 20 mA	
418h	H3-09	Multi-function Analog Input Term A2 Select	1 to 1F		0

Drive Parameter Registers (Read/Write) – continued

REGISTER (in hex)	PARAMETER	PARAMETER FUNCTION	PARAMETER SETTING	LIMITS / DESCRIPTION	INITIAL VALUE
419h	H3-10	Multi-function Analog Input Term A2 Gain		0.0 to 1000.0%	100.0
41Ah	H3-11	Multi-function Analog Input Term A2 Bias		-100.0 to +100.0%	0.0
41Bh	H3-12	Analog Input Filter Time Constant		0.00 to 2.00 seconds	0.00
41Dh	H4-01	Multi-function Analog Output 1 Selection (Terminal FM)		1 to 67H	2
41Eh	H4-02	Multi-function Analog Output 1 Gain		0.00 to 1000.0%	100.0
41Fh	H4-03	Multi-function Analog Output 1 Bias		-110.0 to +110.0%	0.0
420h	H4-04	Multi-function Analog Output 2 Selection (Terminal AM)		1 to 67H	3
421h	H4-05	Multi-function Analog Output 2 Gain		0.00 to 1000.0%	50.0
422h	H4-06	Multi-function Analog Output 2 Bias		-110.0 to +110.0%	0.0
423h	H4-07	Multi-function Analog Output 1 Signal Level Selection (Terminal FM)	0	0 to 10 V DC	0
			1	-10 to +10 V DC	
			2	4 to 20 mA	
424h	H4-08	Multi-function Analog Output 2 Signal Level Selection (Terminal AM)	0	0 to 10 V DC	0
			1	-10 to +10 V DC	
			2	4 to 20 mA	
425h	H5-01	Serial Communication Address		0 to 20H	1F
426h	H5-02	Serial Communication Baud Rate	0	1200 bps	3
			1	2400 bps	
			2	4800 bps	
			3	9600 bps	
			4	19200 bps	
427h	H5-03	Serial Communication Parity Selection	0	No Parity	0
			1	Even Parity	
			2	Odd Parity	
428h	H5-04	Stopping Method after Serial Communication Error	0	Ramp to Stop	1
			1	Coast to Stop	
			2	Fast-Stop	
			3	Alarm Only	
429h	H5-05	Communication Error (CE) Detection Selection	0	Disabled	1
			1	Enabled	

Drive Parameter Registers (Read/Write) – continued

REGISTER (in hex)	PARAMETER	PARAMETER FUNCTION	PARAMETER SETTING	LIMITS / DESCRIPTION	INITIAL VALUE
42Ah	H5-06	Send Waiting Time		5 ~ 65 mSec	5
42Bh	H5-07	RTS Control Select	0	Disabled (RTS is always on)	1
			1	Enabled (RTS is on only when sending)	
42Ch	H6-01	Pulse Input Function Select	0	Frequency Reference (B3-01)	0
			1	PID Feedback	
			2	PID Set Point	
42Dh	H6-02	Pulse Input Scaling		1000 ~ 32000 Hz	1440
42Eh	H6-03	Pulse Input Gain		0.0 ~ 1000.0%	100.0
42Fh	H6-04	Pulse Input Bias		-100.0 ~ 110.0%	0.0
430h	H6-05	Pulse Input Filter Time		0.00 ~ 2.00 Sec	0.10
431h	H6-06	Pulse Output Selection		1,2,5,20,24	2
432h	H6-07	Pulse Output Scaling		0 ~ 32000 Hz	1440
480h	L1-01	Motor Overload Protection Selection	0	Disabled	3
			1	Std Fan Cooled	
			2	Std Blower Cooled	
			3	Vector Motor	
481h	L1-02	Motor Overload Protection Time Constant		0.1 to 20.0 Minutes	8.0
482h	L1-03	Motor Overheat Alarm Operation Selection	0	Alarm: Decel to Stop	3
			1	Alarm: Coast To Stop	
			2	Alarm: Fast-Stop (B5-08)	
			3	Alarm: Alarm Only OH3 Flashes on D.O,	
			4	Alarm: Stop by B3-03 Method	
483h	L1-04	Motor Overheat Operation Selection	0	Decel To Stop	2
			1	Coast To Stop	
			2	Fast Stop by B5-08 Deceleration Time	
484h	L1-05	Motor Temp Input Filter Time Constant		0.00 ~ 10.00 Sec	0.20
485h	L2-01	Momentary Power Loss Detection	0	Disabled	0
			1	Powerloss Ride Thru Time	
			2	While CPU Power Active	
486h	L2-02	Momentary Powerloss Ride Through Time		0.0 ~ 25.5 Sec	(1)

Notes (for this page only):

(1) Initial Value differs depending on the drive capacity(O2-04)

Drive Parameter Registers (Read/Write) – continued

487h	L2-03	Minimum Base Block Time	0.1 ~ 5.0 Seconds		(1)
488h	L2-04	Pwrl V/F Ramp Time	0.0 ~ 5.0 Seconds		0.3
489h	L2-05	Undervoltage Detection Level	230VAC: 150 ~ 210 VDC 460VAC: 300 ~ 410 VDC		190 380
48Fh	L3-01	Stall Prevention Selection during Acceleration	0	Disabled	1
			1	General-purpose	
			2	Intelligent (2)	
490h	L3-02	Stall Prevention Level during Accel	0 to 200%		150 (1)
491h	L3-03	Stall Prevention Level during Accel (CHP)	0 to 100%		50
492h	L3-04	Stall Prevention Selection during Deceleration	0	Disabled	0
			1	General-purpose	
			2	Intelligent (2)	
			3	Stall Prevent with Braking Resistor	
493h	L3-05	Stall Prevention Selection during Running	0	Disabled	1
			1	Decel time 1	
			2	Decel time 2	
494h	L3-06	Stall Prevention Level during Running	30 to 200%		150(1)
499h	L4-01	Speed Agree 1 Level	0.0 ~ 300.0 CT 0.0 ~ 400.0 VT		0.0
49Ah	L4-02	Speed Agree 1 Width	0.0 to 20.0 Hz		2.0
49Bh	L4-03	Speed Agree 2 Level (+/-)	-400.0 to +400.0 Hz		0.0
49Ch	L4-04	Speed Agree 2 Width	0.0 to 20.0 Hz		2.0
48Eh	L4-05	Frequency Reference Loss Detection	0	Stop	0
			1	Run at 80% of Frequency Reference	

Notes (for this page only):

(1) Initial value differs depending on drive capacity.

(2) When Vector Control (A1-02 = 2 or 3) is selected, set value 2 (intelligent) cannot be used.

Drive Parameter Registers (Read/Write) – continued

REGISTER (in hex)	PARAMETER	PARAMETER FUNCTION	PARAMETER SETTING	LIMITS / DESCRIPTION	INITIAL VALUE
4A1h	L6-01	Torque Detection Selection 1	0	Disabled	0
			1	Alarm: OT @ Spd Agree	
			2	Alarm: OT @ Run	
			3	Fault: OT @ Spd Agree	
			4	Fault: OT @ Run	
			5	Alarm: UT @ Spd Agree	
			6	Alarm: UT @ Run	
			7	Fault: UT @ Spd Agree	
8	Fault: UT @ Run				
4A2h	L6-02	Torque Detection Level 1	0 to 300%		150
4A3h	L6-03	Torque Detection Time 1	0.0 to 10.0 seconds		0.1
4A4h	L6-04	Torque Detection Selection 2	0	Disabled	0
			1	Alarm: OT @ Spd Agree	
			2	Alarm: OT @ Run	
			3	Fault: OT @ Spd Agree	
			4	Fault: OT @ Run	
			5	Alarm: UT @ Spd Agree	
			6	Alarm: UT @ Run	
			7	Fault: UT @ Spd Agree	
8	Fault: UT @ Run				
4A5h	L6-05	Torque Detection Level 2	0 to 300%		150
4A6h	L6-06	Torque Detection Time 2	0.0 to 10.0 seconds		0.1
4AEh	L8-02	oH (Overheat) Protection Alarm LvL	50 to 110 °C		95 (1)
4AFh	L8-03	Operation Selection after oH (Overheat) Pre-alarm	0	Ramp to Stop	3
			1	Coast to Stop	
			2	Fast-stop	
			3	Alarm Only	

Notes (for this page only):

(1) Initial value differs depending on drive capacity.

Drive Parameter Registers (Read/Write) – continued

REGISTER (in hex)	PARAMETER	PARAMETER FUNCTION	PARAMETER SETTING	LIMITS / DESCRIPTION	INITIAL VALUE
4B1h	L8-05	Input Phase Loss Protection	0	Disabled	1
			1	Enabled	
4B3h	L8-07	Output Phase Loss Protection	0	Disabled	2
			1	Enabled: 1 PH Loss Det	
			2	Enabled: 2/3 Loss Det	
4B5h	L8-09	Ground Fault Detection	0	Disabled	1
			1	Enabled	
4B6h	L8-10	Cooling Fan Operation Select	0	Fan On-Run Mode	0
			1	Fan Always On	
4B7h	L8-11	Cooling Fan On/Off Delay Time	0 ~ 300 Seconds		60
4B8h	L8-12	Ambient Temperature	45 ~ 60 Deg C		45
4BBh	L8-15	OL2 Select @ Low Speed	0	Disabled: OL Disabled @ Low Speed	1 (1)
			1	Enabled	
4BEh	L8-18	Soft CLA Selection	0	Disabled	0
			1	Enabled	
4BFh	L9-01	Auto Restart Operation Selection	0	Disabled	1
			1	Enabled	
4C0h	L9-02	Number of Auto Restart Attempts	0 to 10		3
4C1h	L9-03	Reset Time	0.0 to 180.0 Seconds		0.5
4C2h	L9-04	Reset Fault Select 1	0000 to FFFF		0001
4C3h	L9-05	Reset Fault Select 2	0000 to FFFF		E000
4C4h	L9-06	Fault Contact Select	0	Disabled: Fault Contact Not Operated	0
			1	Enabled: Fault Contact is Operated	
584h	N2-01	AFR Gain	0.00 ~ 10.00		1.00
585h	N2-02	AFR Time	0 ~ 2000 mSeconds		50
586h	N2-03	AFR Time 2	0 ~ 2000 mSeconds		750
587h	N2-04	AFR Limit	0.0 ~ 60.0 Hz		5.0
500h	O1-01	Monitor Selection	4 to 52		6

Notes (for this page only):

(1) Setting depends on D10-01. When D10-01 = 0, L8-15 will change to 0. When D10-01 = 1 or 2, it will change to 1

Drive Parameter Registers (Read/Write) – continued

REGISTER (in hex)	PARAMETER	PARAMETER FUNCTION	PARAMETER SETTING	LIMITS / DESCRIPTION	INITIAL VALUE
501h	O1-02	Monitor Selection after Power-up	1	Frequency Reference	1
			2	Output Frequency	
			3	Output Current	
			4	Monitor item Set by O1-01	
502h	O1-03	Digital Operator Display Scaling		0 ~ 39999	0
503h	O1-04	Digital Operator Display Units	0	Hz	0
			1	RPM	
504h	O1-05	LCD Brightness Adjust		0 ~ 5	3
505h	O2-01	Mode Service Key Select	0	Mode/Service	0
			1	Local/Remote	
506h	O2-02	Stop Key Function Selection	0	Coast To Stop	0
			1	Decel To Stop	
			2	Use B3-03 Method	
507h	O2-03	User Parameter Initialization Selection	0	No Change	0
			1	Set Defaults	
			2	Clear All	
508h	O2-04	KVA Selection		0 ~ FF	0
509h	O2-05	Operator M.O.P.	0	Disabled: Enter Key Required	0
			1	Enabled: Enter Key is not Required	
50Ah	O2-06	Digital Operator Detection	0	Disabled	1
			1	Enabled	
50Bh	O2-07	Elapsed Timer Setting		0 ~ 65535 Hour	0
50Ch	O2-08	Elapsed Timer Selection	0	Power On Time	1
			1	Running Time	
50Eh	O2-10	Fan Operating Time Setting		0 ~ 65535 Hour	0
515h	O3-01	Clear Fault history	0	Not Clear U2/U3	0
			1	Clear U2/U3	
516h	O3-02	Clear Count History	0	Not Clear	0
			1	Accumulated Operation Clear (U3-21 ~ 22)	
			2	Overload Load Check Clear (U3-23	
			3	Both 1 and 2 Cleared	

Drive Parameter Registers (Read/Write) – continued

REGISTER (in hex)	PARAMETER	PARAMETER FUNCTION	PARAMETER SETTING	LIMITS / DESCRIPTION	INITIAL VALUE
517h	O4-01	Copy Function Select	0	Copy Select	0
			1	Read: Inverter → Operator	
			2	Operator → Inverter	
			3	OP → Inverter Verify	
518h	O4-02	Read Selection	0	Disabled	1
			1	Enabled	
700h	T1-00	Motor Selection 1/2	0	1 st Motor	0
			1	2 nd Motor	
701h	T1-01	Tuning Mode Selection	0	Rotational Tune	0
			1	Stationary Auto Tune	
			2	Terminal Resistance	
			3	On-Dly Comp Tune	
702h	T1-02	Motor Output Power		0.4 ~ 650.0 HP	0.40
703h	T1-03	Motor Rated Voltage		0 ~ 255.5	230.0 (1)
704h	T1-04	Motor Rated Current		(2)	(3)
705h	T1-05	Base frequency		0 ~ 400.00Hz	60.00
706h	T1-06	Number of Motor Poles		2 ~ 48 Pole	4
707h	T1-07	Rated Motor Speed		0 ~ 24000 RPM	1750
708h	T1-08	PG Pulses/Rev		0 ~ 60000 RPM	1024

Notes (for this page only):

- (1) For 400V class, the value is twice that for the 200V class
- (2) Setting Range is 10 ~ 200% of inverter rated output current
- (3) Initial value differs depending upon inverter capacity

Special Registers (Write only)

REGISTER (in hex)	FUNCTION	DATA SET	DESCRIPTION
F200	Global Write Enable		Global Write Source Address (0=disabled)
F201	Global Frequency Reference Multiplier		Multiplies global freq. reference before being written to drive (1000 = 1.000 multiplier)
FFDDh	'ACCEPT' Command	0	Writes data into Volatile memory
FFFDh	'ENTER' Command	0	Writes data into Non-Volatile memory