

Electric Wire Rope Hoist

Fill in the information below before installing the hoist.

Parts, Instructions and Operation Manual

Hoist Model No. _____

Trolley Model No. _____

Voltage _____

Capacity _____

Date of Purchase _____

Yale

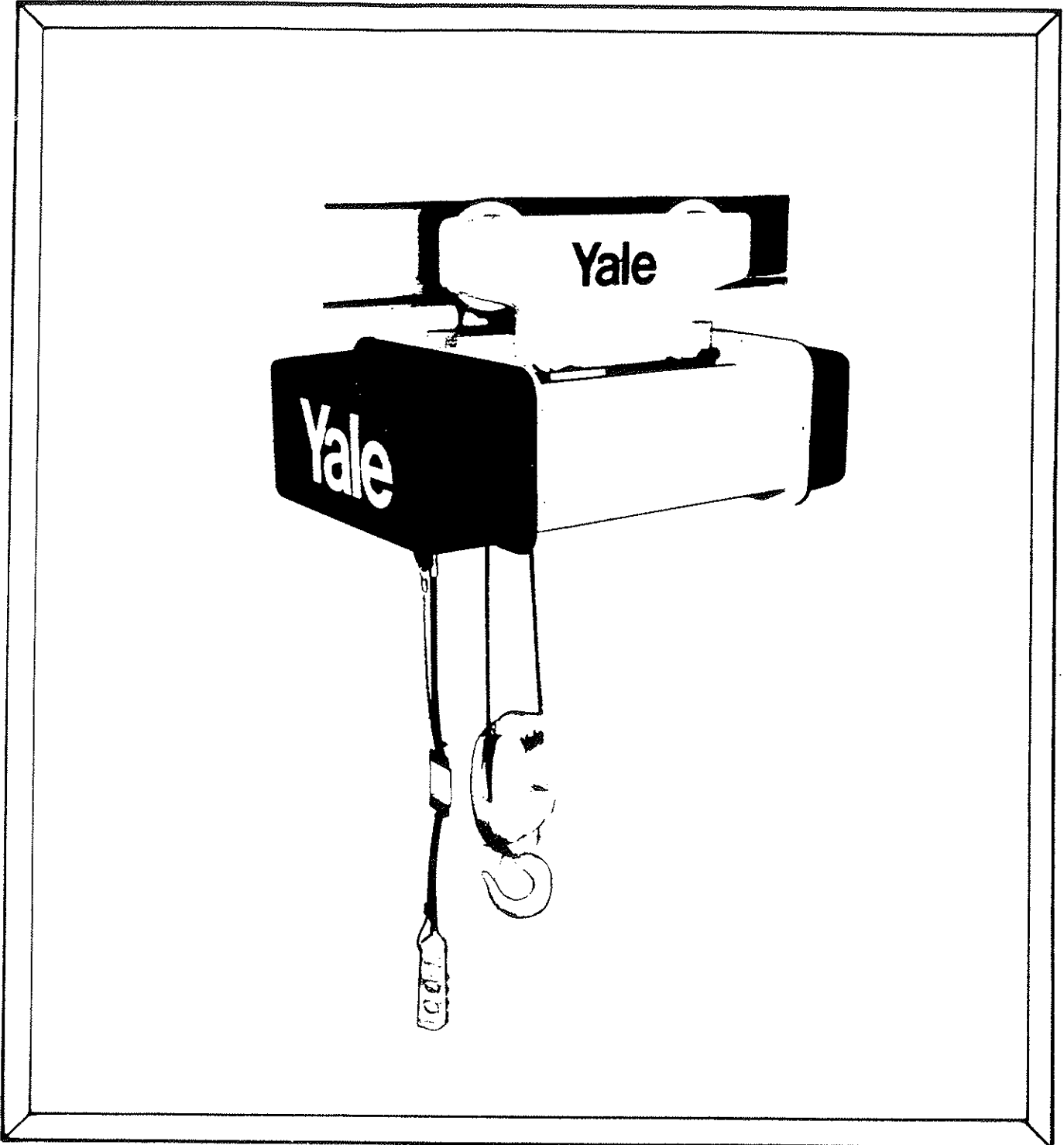

COMMON MODEL NUMBER CODE FOR POWERED HOISTS

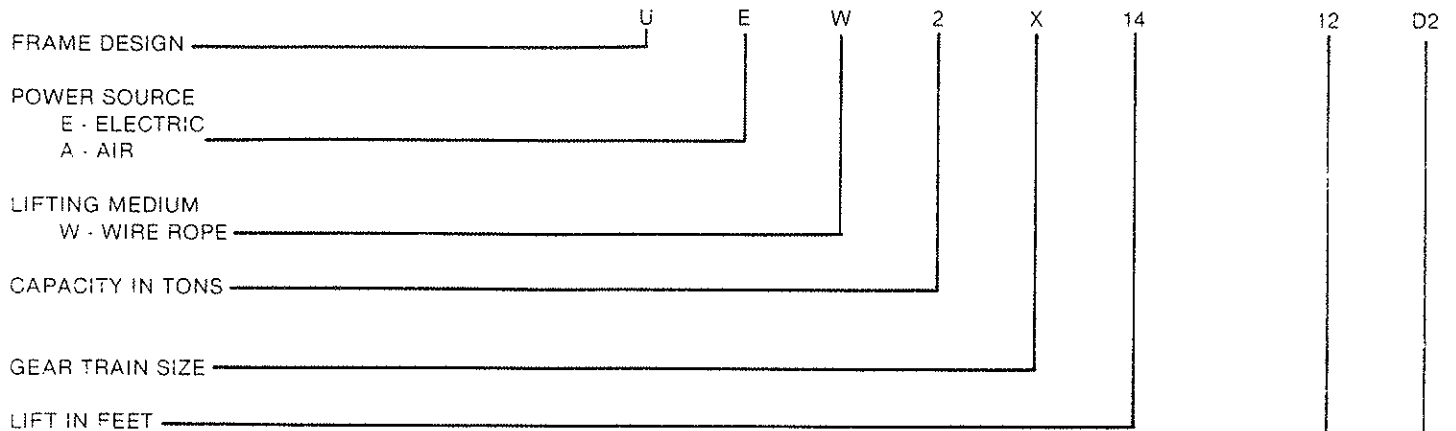

SUSPENSION OR MOUNTING

- | | |
|---------------------------|-----------------------------|
| AM AMERICAN MONORAIL | NC NON ROTATION CLEVIS |
| BM BASE MOUNTED | NH NON ROTATION HOOK |
| CB CRANE BUILDERS SPECIAL | ST ST MOTORIZED TROLLEY |
| CC CLEVIS | SM SPAN MASTER |
| CM CEILING MOUNTED WINCH | TC TWIN CITY |
| CT CLEVELAND TRAMRAIL | TH TOP HOOK |
| DM DECK MOUNTED WINCH | TT TRACTOR TROLLEY |
| FM FOOT MOUNTED WINCH | TR TOP RUNNING TROLLEY |
| GT GEARED TROLLEY | WC WHITING CORPORATION |
| LA LOUDEN ACCO-WRIGHT | WM WALL MOUNTED WINCH |
| LG LUG MOUNTED | WT WT MOTORIZED TROLLEY |
| LP LOW PROFILE TOP RUNNER | TL TOP RUNNER LESS CARRIERS |
| PT PLAIN TROLLEY | |

SPEED IN FPM

REEVING

- | | |
|------------------------------|--|
| S = STANDARD HEADROOM | X = STD. HEADROOM, SPECIAL RIGHT ANGLE MTG. |
| S1 ONE PART SINGLE REEVED | X1 ONE PART SINGLE REEVED |
| S2 TWO PART SINGLE REEVED | X2 TWO PART SINGLE REEVED |
| S3 THREE PART SINGLE REEVED | X3 THREE PART SINGLE REEVED |
| S4 FOUR PART SINGLE REEVED | X4 FOUR PART SINGLE REEVED |
| D = CLOSE HEADROOM | P = CLOSE HEADROOM, SPECIAL PARALLEL MTG. |
| D1 ONE PART DOUBLE REEVED | P1 ONE PART DOUBLE REEVED |
| D2 TWO PART DOUBLE REEVED | P2 TWO PART DOUBLE REEVED |
| D3 THREE PART DOUBLE REEVED | P3 THREE PART DOUBLE REEVED |
| D4 FOUR PART DOUBLE REEVED | P4 FOUR PART DOUBLE REEVED |
| D5 FIVE PART DOUBLE REEVED | P5 FIVE PART DOUBLE REEVED |
| D6 SIX PART DOUBLE REEVED | P6 SIX PART DOUBLE REEVED |

When Replacement Parts Are Needed, Order Only Yale® Factory Engineered Parts

SECTION A

SAFE HOISTING PRACTICES

For your own safety and that of your fellow workers, Material Handling Equipment must be used as recommended by the manufacturer. Failure to heed the following recommendations could endanger your life. Use good common sense and judgment at all times. Safety is the responsibility of the operator of the equipment. You must be competent and attempt to foresee and avoid all hazardous conditions. To be safe as possible, the hoist must be given proper preventive maintenance and testing as described in the **ANSI B30.16** Safety Code for Overhead Hoists and this manual.

BEFORE OPERATING HOIST-OPERATOR MUST READ THIS MANUAL;

1. Do not operate hoist unless you are properly trained, physically fit, and authorized to do so. You must be familiar with all operating controls of the hoist, warnings and instructions on the hoist, the safe hoisting practices listed in this manual, **ANSI B30.16** Safety Code for Overhead Hoists, and all pertinent Federal, State, and Local regulations before beginning operating.
2. Do not allow unqualified personnel to operate the hoist.
3. Test all controls and limit switches and make sure hoist is well lubricated at beginning of each shift. Make sure needed lubrication, adjustments or repairs are made by appointed personnel before operations are begun.
4. Be familiar with the equipment and its proper care. Do not operate hoist if adjustments or repairs are necessary, if any damage or undue wear is known or suspected, or if any warning, operating, or capacity instructions normally attached to hoist are damaged, obscured or missing. Report these items promptly to the proper person and also notify next operator when changing shifts.
5. Do not operate hoist if it is functioning improperly.
6. Do not operate hoist with an out - of - order sign attached until sign has been removed by a properly authorized person.
7. Do not adjust or repair hoist unless qualified for maintenance of hoist.
8. Be sure the power supply is disconnected before maintenance and repair procedure is performed.
9. Do not use the wire rope as a ground for welding.
10. Do not touch a welding electrode to the wire rope.

APPLYING THE LOAD

11. Never wrap the wire rope around the load, or allow it to drag under load.
12. Always use slings or other approved devices to attach load.
13. Be sure the sling is properly seated in the saddle of the hook. Do not allow hook latch to support any part of load.

When Replacement Parts Are Needed, Order Only Yale® Factory Engineered Parts

APPLYING LOAD (Continued)

14. Do not apply a load to tip of hook, or in such a way as to cause bending or prying forces on the hook or hook support block.
15. Be sure wire ropes are not kinked or twisted or that multiple part ropes are not twisted about each other.
16. Do not operate hoist if wire rope is not seated properly in the grooves of the drum or sheaves.
17. Do not load hoist with less than two wraps of rope on the drum, unless a lower limit device is provided, in which case, no less than one wrap shall remain on drum.
18. Center hoist unit over the load before lifting. Avoid side pull.
19. Never pick up a load beyond the rated capacity appearing on the hoist, except for properly authorized tests.
20. Do not use a load limiting device to measure the maximum load to be lifted. It is a safety device only.

MOVING THE LOAD

21. Do not engage in any activity which will divert your attention while operating hoist.
22. Respond to signals from designated personnel only, except for stop signals.
23. Never lift a load with the hoist until you and all other personnel are clear of load.
24. Never carry personnel on the hook or the load.
25. Inch the hoist slowly into engagement with a load, but avoid excessive plugging, inching, and quick reversals of load.
26. Do not lift load more than a few inches until it is well balanced in the sling or lifting device.
27. Each time a load approaching rated capacity is handled, check load brake action by raising load just clear of supports and continuing only after you are sure brake is operating properly.
28. Do not transport load over personnel.
29. Make sure load has proper clearance before moving.
30. Avoid swinging of load or load hook when traveling the hoist.
31. On trolley mounted hoists, avoid sharp contact between trolleys or between trolleys and rail stops.
32. Do not use limit devices as a normal means of stopping the hoist. These are emergency devices only.
33. Do not exceed the maximum duty cycle specified by the manufacturer.

When Replacement Parts Are Needed, Order Only Yale® Factory Engineered Parts

SECTION A

PARKING

34. Do not leave load suspended in the air for extended or unattended periods.
35. Keep load block above head level when not in use.

SAFETY LAWS FOR PASSENGER ELEVATORS

 **CAUTION DO NOT USE YALE HOISTS OR TROLLEYS FOR PASSENGER ELEVATOR APPLICATIONS.**

The safety laws for passenger elevators specify construction details that are not incorporated in Yale Industrial Hoists. We recommend that passenger elevator operation equipment be used that meets all state and national safety codes. Yale Industrial Products, Inc. will not accept responsibility for applications of Yale Hoists on passenger elevators.

INSPECTION, PREVENTIVE MAINTENANCE AND TESTING

A preventive maintenance program should be initiated for this hoist immediately after it is entered into service. The preventive maintenance program should comply with recommendations in the applicable Yale Parts and Instruction Manual, and all pertinent National, Federal, State and local regulations. Regular inspections, maintenance, and testing required should be followed for the life of the hoist and written inspection records kept as specified. Sample inspection check lists are included at back of this manual. Extra inspection check lists can be obtained from your nearest authorized Yale Distributor.

When Replacement Parts Are Needed, Order Only Yale® Factory Engineered Parts

REPAIR PARTS ORDERING INFORMATION

This parts and instruction manual contains information required to install and maintain your Yale UEW Series Hoist. To insure prompt service, each repair parts order should be placed with your local distributor, and must contain the following information:

Please give all information listed below in items (a) thru (e). This will enable your distributor to fill your order promptly.

- (a) Give complete data from hoist nameplate, including hoist serial number, model number, voltage, frequency, and hertz.
- (b) Give part numbers, description and quantity of parts required.
- (c) Give correct shipping destination.
- (d) For ordering motor repair parts, give all data on the hoist and motor nameplates.
- (e) If hoist has been purchased for a special application or environment (such as plating, spark resistant, special hook, special controls, etc.), some of the standard parts listed in this manual may not apply and some special parts may not be shown. In such cases you should contact the factory or your nearest Yale authorized repair station for assistance in ordering parts. A full description of the special application or environment for which the hoist has been adapted will be required.

HOIST SERIAL NUMBERS

The hoist serial number is stamped in the nameplate. Trolley serial numbers are stamped on the trolley sideplate. The nameplates also designate the model number, capacity, speed, current characteristics, and service rating of the hoist or trolley.

RETURN OF PARTS

If it becomes necessary to return the complete hoist or certain parts to the factory, a letter requesting such a return is necessary. This letter should contain an explanation for requesting the return. A return authorization will be issued giving you clearance for returning the hoist or parts to the factory.

INSTALLATION INSTRUCTIONS

Before the unit is shipped from the factory it is rigidly tested and carefully adjusted for proper operation. However, the following points must be checked to insure correct installation and avoid damage to the hoist.

Suspension - Suspend the hoist following the installation procedures for the type of suspension used on your hoist. See pages 8.

Rope And Drum - Check the hoist rope for any signs of damage and make sure it lies properly in the grooves of the drum and sheaves. Make sure the rope is well lubricated. (See chart on page 13.)

 **CAUTION** BEFORE OPERATING THE HOIST, REMOVE THE WOODEN SHIPPING WEDGE

Current Supply - Make sure the electric current supply corresponds with the rating listed on the hoist nameplate. Make sure duty cycle capabilities of hoist are fully understood by all operators.

Electrical Connections - Open the control box and check all the electrical connections to be sure they are tight and that none of the hardware vibrated loose during shipment.

Connect the **power lines** to the point on the reversing switch indicated by the tag and remove tag. If current collectors are used, be sure they make good contact with the conductor bars.

 **CAUTION** THE HOIST MUST BE GROUNDED. TO DO THIS, CONNECT ONE END OF THE GREEN WIRE IN THE POWER CORD TO A SOLID GROUND AND THE OTHER END TO THE SPECIFIED GROUNDING LUG PROVIDED ON THE HOIST.

Push Button Control

 **CAUTION** ON POLY PHASE AC HOISTS, IT IS IMPOSSIBLE TO KNOW HOW TO CONNECT THE POWER LINE FOR CORRECT DIRECTION OF THE HOOK TRAVEL.

TO INSURE CORRECT OPERATION OF THE SAFETY LIMIT STOPS IT IS VERY IMPORTANT THAT THE HOOK TRAVEL IS IN THE HOISTING DIRECTION WHEN THE UP BUTTON IS PRESSED. IF IT IS NOT, INTERCHANGE TWO OF THE LINE WIRES FOR 3 PHASE OR TWO OF THE LINE WIRES OF ANY ONE PHASE FOR 2 PHASE OPERATION. IF THE HOIST IS OPERATED WITH INCORRECT POWER CONNECTIONS THE SAFETY LIMIT STOPS WILL BE INEFFECTIVE AND SERIOUS HOIST DAMAGE AND DANGEROUS ACCIDENTS MAY RESULT.

 **CAUTION** DO NOT ATTEMPT TO REWIRE THE PUSH BUTTON.

When Replacement Parts Are Needed, Order Only Yale® Factory Engineered Parts

Adjustment Of Limit Switches

1. UPPER AND LOWER LIMIT SWITCH.



WARNING EACH STEP OUTLINED BELOW MUST BE FOLLOWED FOR PROTECTION AGAINST ELECTRICAL SHOCK AND INJURY FROM MOVING COMPONENTS.

To adjust the traveling nut limit switches, or to set them at other levels:

- (a) Remove all electrical power from the hoist.
- (b) Remove control cover.
- (c) Adjustment **cams** rotate in a clockwise direction when hoist is lifting and in a counter-clockwise direction when lowering.
- (d) For upper limit switch, move the adjusting disc.
- (e) For lower limit switch, move the adjusting disc.
- (f) Each **cam** includes two movable sectors independent from each other (one red and one grey).
- (g) Move each of the two red and grey discs in the desired direction keeping a gap of $3/8$ " between the discs.



WARNING AT LEAST 1 WRAP OF ROPE MUST REMAIN ON THE DRUM IN THE LOWEST POSITION.

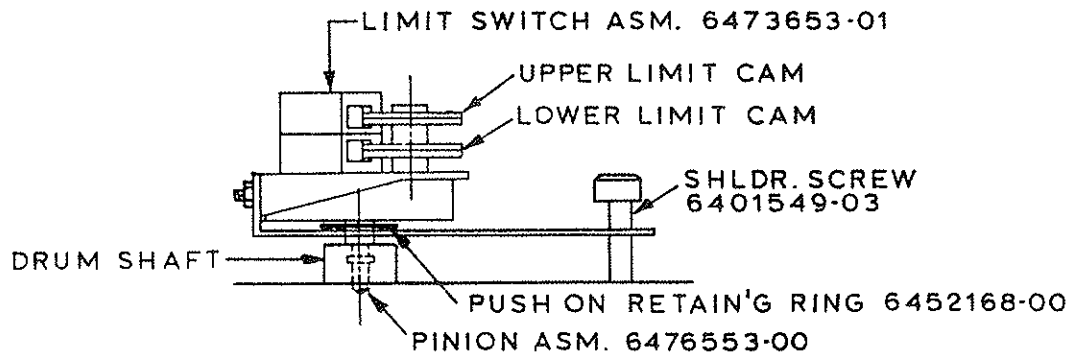
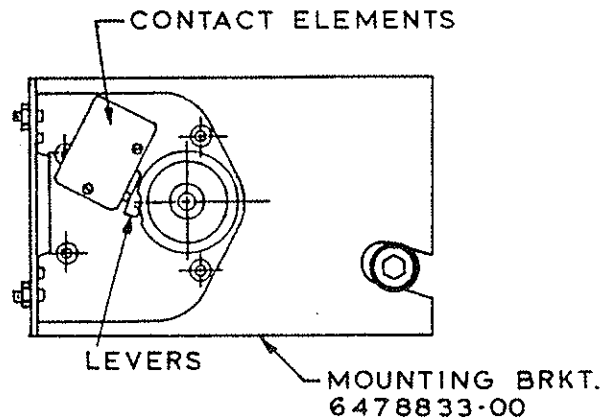
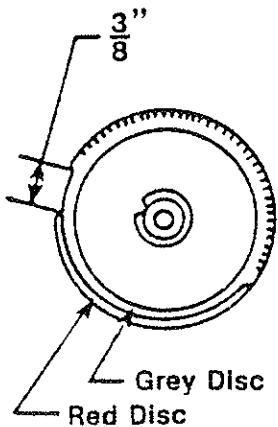

When Replacement Parts Are Needed, Order Only Yale® Factory Engineered Parts

Basic Suspensions - The basic hoist suspension types are ; lug mounted, frame mounted plain trolley, hand chain operated trolley and single beam under running motorized trolley. Before connecting hoist to supporting structure, or mounting on beam or rail, make sure supporting structure has adequate strength to safely support the loading which will be imposed.

When installing lug mounted types, make sure hoist is bolted securely in place with the proper size bolts, that it is level, that nuts on mounting hole bolts are tightened securely, and the lockwashers, or other means of locking the nuts are used.

If hoist is furnished with a motorized trolley, record the serial number in this book for future reference, and refer to the trolley manual included.

To hang hoist furnished with plain, hand chain operated, motorized trolley, first determine the beam size on which the trolley is to be used, then refer to trolley adjustment instructions below for proper spacer arrangements.

Trolley Adjustment - All Yale under running trolleys are properly adjusted at the factory to fit the I-Beam size stated on the order.

NOTE: When disassembling the trolley for installation on the I-Beam, take note of the arrangement of the spacers and washers for correct reassembly.

For installation on I-Beam other than the size preset at the factory, follow the instructions listed below,

Measure the I-Beam flange width and temporarily install the trolley sideplates on the hoist before installation to determine the exact distribution of washers.

The distance between track wheel flanges should be $3/16$ inches greater than the beam flange width for straight runway beams, and $3/16$ to $1/4$ inches on runway systems that include sharp curves. To keep the hoist centered under the I-Beam, the number of washers between the sideplates and the hoist lug should be the same or differ only by one (1) washer. The distribution of washers outside the trolley sideplates is unimportant except that the total number used must be sufficient to keep the nuts engaged.

NOTE: When installing hoist and trolley on beam, tighten nuts snugly so that the trolley sideplates are parallel and vertical.

 **CAUTION BE SURE THERE IS A LOCKWASHER UNDER EACH NUT.**

After the hoist and trolley are installed on the I-Beam, operate the trolley over the entire length of the beam with a capacity load to be sure that adjustment and operation is satisfactory. Then tighten all sideplate nuts to maximum standard torque for bolt size used.

Trolley With Guide Rollers - To adjust trolleys equipped with guide rollers add spacers in even quantities on each side of the spacer block until the distance between guide rollers is $1/8$ inches wider than the beam flange width.

NOTE: When properly installed and adjusted the guide rollers should be $1/16$ inches from the edge of the I-Beam.

When Replacement Parts Are Needed, Order Only Yale® Factory Engineered Parts

PREVENTIVE MAINTENANCE SCHEDULE

The required periods between inspections will vary due to the wide range of duty cycles and operating conditions encountered with the type of equipment. The following recommended inspection periods are based on duty of specified service rating with single shift operation (40 hours per week) under normal environmental conditions. If the hoist is used under adverse environmental conditions it should be inspected more frequently,

Daily Inspection - Inspect the following items before operating hoist.

- 1 **Manual Controls** - Check all manual controls for proper operation.
- 2 **Electrical Connections** - Check for worn or frayed wires, for loose connections and for damage to, or improper operation of, push button assembly.
- 3 **Limit Switch** - Check the upper and lower limit switch by running the hook **without load**, and at the slowest speed obtainable, to the maximum up and maximum down positions. Then test with increasing speeds up to maximum. The switch should shut the hoist off before the bottom block contacts the rod or weight type limit switch at the upper extreme. 1 Wrap of rope should remain on the drum at the shut-off point at the lowest extreme. If adjustment is necessary, see page 7.
- 4 **Hook** - Check for cracks or deformation. Check for damaged or missing latch. A bent or twisted hook indicates overloading or abuse of unit. Other load bearing components of the hoist or trolley should be inspected if overloading is apparent or suspected. The bottom hook must swivel freely.
- 5 **Wire Rope** - Check for proper seating in drum grooves. Check for wear, unstranding, fraying, kinks, or broken wires in the wire rope, and condition of end connections. (If damage is noted, see wire rope instructions under monthly inspection.)
- 6 **Hook Drift** - With a load, the hook should stop promptly when the push button is released. Hook drift of more than 2 inches indicates that the hoist brake is malfunctioning. (See monthly and annual inspection instructions for more details.)
7. **Unusual Conditions** - Excessive noise, lubrication leaks, etc. should be investigated.

 **CAUTION: DO NOT OPERATE THE HOIST IF ABOVE INSPECTION INDICATES THAT MAINTENANCE IS NEEDED.**

Monthly Inspection

1. ALL ITEMS UNDER DAILY INSPECTION.
2. **Hook** - Check hook retaining nuts and collars, and means used to secure them. Replace hook if throat opening is in excess of maximum shown in table on page 12, or if there is 10 degrees or more twist from normal plane of hook.
3. **Brake** - Check the function of the brake by lifting a light load (approximately 25% of rated load) 6 to 12 inches above the floor.
4. **Contactors** - Check for burned or badly pitted contacts.
5. **Push Button** - Check the ground connections to be sure that the wire cores from the push button cable and the power cord are secured. Tighten the grounding screw and replace the lockwasher if it is missing. On two button station, replace push button pendant when diaphragm buttons become cracked.

When Replacement Parts Are Needed, Order Only Yale® Factory Engineered Parts

SECTION B

Monthly Inspection (Continued)

6. **Bearings** - Check all bearings for noisy operation, which is an indication of wear.
7. **Hardware** - Check for loose bolts, nuts and rivets.
8. **Wire Rope** - Check condition of wire rope using inspection check list. (See instructions page 14.)
Lubricate per chart on page 13 needed.

 **WARNING** **NEVER ALLOW WIRE ROPE TO OPERATE DRY.**

9. **Warning Labels** - Check for absence or illegibility of warning decals and tags and replace if necessary.
10. **Supporting Structure Or Trolley** - If used, should be checked for continued ability to support the imposed loads. Check for loose suspension or support bolts, axle nuts, etc.
11. **Inspection Check List** - Fill out inspection check list at the back of this manual, sign, date and file for future reference.

Quarterly Inspection

1. ALL ITEMS UNDER DAILY AND MONTHLY INSPECTIONS.
2. **Gearing** - Remove gearbox cover and visually inspect gearing for excessive or uneven wear of the gear teeth. Replace if necessary.
3. **Brake** - Check for excessive or uneven disc wear. Clean solenoid plunger seat and check for uneven seating between the plunger and coil.

When Replacement Parts Are Needed, Order Only Yale® Factory Engineered Parts

Annual Inspection

1. ALL ITEMS UNDER DAILY, MONTHLY AND QUARTERLY INSPECTIONS.
2. Hooks - Magnetic particle or other suitable crack detecting inspection should be performed if need is indicated by external appearance. Check for loose retaining nuts and collars.
3. Load Bearing Parts - Check for worn, cracked or distorted parts, such as suspension housings, outriggers, clevises, yokes, hook blocks, suspension bolts, shafts, locking devices and bearings on hoist, (also on trolley, if so equipped).

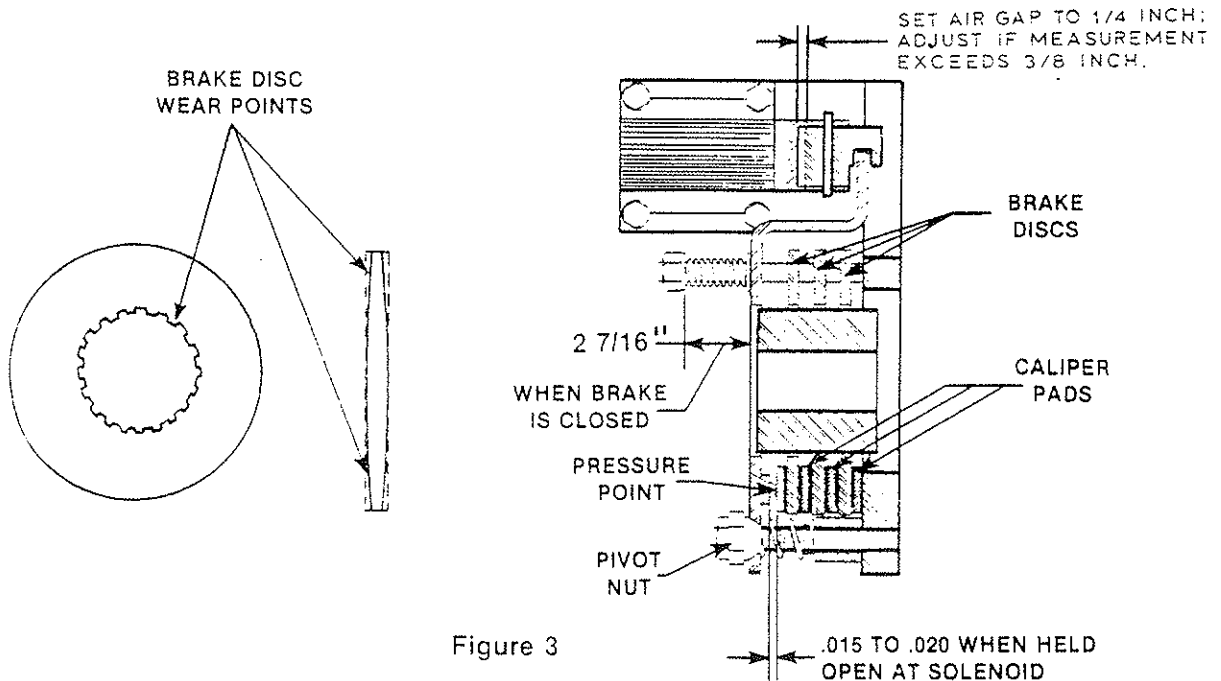

Figure 3

4. Hoist Brake - Check for excessive or uneven wear of the discs and caliper pads, and excessive play between the splines in the discs and the brake hub. Clean the solenoid plunger seat and check for uneven seating between the plunger and the coil. Manually hold the brake open and check adjustment as shown in Fig. 3.



CAUTION

PRIOR TO TESTING, ALL SUPPORTING STRUCTURES, ANCHORAGES, AND/OR SUSPENSIONS MUST BE APPROVED BY THE APPOINTED PERSON FOR THE TEST LOADS USED

When Replacement Parts Are Needed, Order Only Yale[®] Factory Engineered Parts

Annual Inspection (Cont'd.)

5. **Wiring And Terminals** - See that all connections are tight. Terminals are to be securely crimped to wires and the insulation sound. Bent terminals can usually be straightened to provide a tight fit. Replace terminals or wire if necessary.
6. **Sheaves And Drums** - Inspect rope sheaves and drums for excessive wear. When the groove of a sheave or rope drum becomes worn excessively it should be replaced. Worn grooves on the drum or sheave can greatly reduce the useful life of the hoisting rope.
7. **Bearing Lubrication** - The motor, sheave and outer drum bearings are packed with grease at the factory and normally will not need to be lubricated. If conditions require, repack with grease as needed.
8. **Inspection Check List** - Fill out inspection check list at the back of this manual, sign, date and file for future reference.

FUNCTION TESTING AFTER REPAIR

After repair or replacement of parts, function test hoist by operating unloaded hoist into both upper and lower limits, first with slowest speed possible, then with increasing speeds up to maximum. Limit switch mechanisms must be adjusted so they will trip in sufficient time to prevent damage to any part of the hoisting arrangement. See instructions for adjustment of limit switches on page 7. Then test operation of hoist and brake by lifting 100% of rated load. (A normal load lifted may be substituted if no load bearing parts were altered.) A written report of the test should be prepared by the person responsible and kept on file for future reference.

CAUTION PRIOR TO TESTING ALL SUPPORTING STRUCTURES, ANCHORAGES, AND/OR SUSPENSIONS MUST BE APPROVED BY THE APPOINTED PERSON FOR THE TEST LOADS USED.

HOOK DIMENSIONS

CAPACITY IN TONS	E (in.) NORMAL	E (in.) MAXIMUM
1/2	1 1/32	1 7/32
1	1 9/64	1 11/32
1 1/2	1 21/64	1 9/16
2	1 21/64	1 9/16
2 1/2	1 15/16	2 1/4
3	1 15/16	2 1/4
5	1 15/16	2 1/4
6	1 15/16	2 1/4
7 1/2	1 15/16	2 1/4
8	3 1/16	3 9/16
10	3 1/16	3 9/16



WARNING

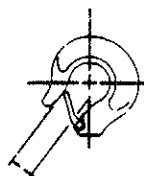

E OPENING WITH LATCH

IF "E" EXCEEDS
MAXIMUM SHOWN
IN TABLE, REPLACE
HOOK AND CHECK OTHER
LOAD BEARING PARTS

When Replacement Parts Are Needed, Order Only Yale® Factory Engineered Parts

**LUBRICATION
HOIST**

PART	LUBRICANT	LUBRICATION POINT	LUBRICATION INSTRUCTIONS	DRAIN POINT
Gear-case	Moly Cote Grease	Pinion & Gear Teeth		
Wire Rope	Keystone WRD-OW Spray Type Wire Rope Dressing, Or Other Prepared Cable Lubricant	Wire Rope	Light Coat Of Lubricant	

PLAIN AND HAND CHAIN OPERATED TROLLEYS

Alemite Fittings	GULF EP No. 2, Grease or equal
Ball Valve Oil Holes	Light Machine Oil

ST, WT RT, & TR SERIES TROLLEYS

PART	LUBRICANT	LUBRICATION POINT	LUBRICATION INSTRUCTIONS	DRAIN POINT
Gear-Case	Gulf EP No. 2 Grease Or Equal For ST. Use 140 EP Gear Oil For WT And TR	Socket Head Plug In side of Gearcase	Fill Until Lubricant Is Level With Hole	Socket Head Plug In Bottom Of Gearcase
Track Wheel Pinion & Gear Teeth	Moly Cote Grease	Pinion & Gear Teeth	Depending On Applications Light Coating Of Grease	

TT SERIES TROLLEYS

PART	LUBRICANT	LUBRICATION POINT	LUBRICATION INSTRUCTIONS	DRAIN POINT
Gear-case & Chain Case	Gulf EP No. 2 Grease Or Equal	Socket Head Plug On Side Of Chain Case	Fill Until Grease Is Level With Hole	Socket Head Plug In Bottom Of Gearcase

When Replacement Parts Are Needed, Order Only Yale® Factory Engineered Parts

WIRE ROPE INSPECTION

All wire rope should be inspected once a month and a signed and dated inspection report maintained. The Inspection Check Lists at back of this manual can be used to record these inspections. Wire rope should be replaced if any of the following conditions are noted.

1. Twelve randomly distributed broken wires in one rope lay, or four broken wires in one strand in one rope lay.
2. Wear of one-third ($1/3$) of the original diameter of outside individual wires.
3. Kinking, crushing, bridging or any distortion of the wire rope structure.
4. Evidence of heat damage.



"Broken Wires"



"Kinked"

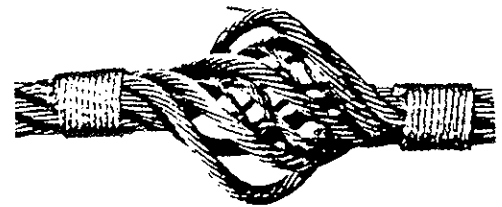

Bird Cage

5. Reductions from nominal diameter of more than the following values.

New Rope Diameter	Maximum Reduction
5/16 Inch and under	1/64 Inch
3/8 Inch Thru 1/2 Inch	1/32 Inch
9/16 Inch Thru 3/4 Inch	3/64 Inch
7/8 Inch Thru 1 1/8 Inch	1/16 Inch

6. Rope sockets should be inspected for broken wires. If broken wires are noted, the rope should be replaced.

**CAUTION**

REPLACEMENT WIRE ROPE SHOULD BE THE SAME SIZE, GRADE AND CONSTRUCTION AS THE ORIGINAL WIRE ROPE. BEFORE REPLACING WIRE ROPE, READ PROCEDURE ON PAGE 19. AFTER WIRE ROPE REPLACEMENT CHECK FOR PROPER LIMIT SWITCH OPERATION. (SEE PAGE 7.)

**CAUTION**

ROPE PILE-UP ON THE HOISTING DRUM WILL SEVERLY DAMAGE THE HOISTING ROPE. IF THIS CONDITION IS NOTED THE HOISTING ROPE SHOULD BE INSPECTED ACCORDING TO THE ABOVE PARAGRAPH ON WIRE ROPE INSPECTION. IF DAMAGED ROPE IS FOUND, CHECK DRUM AND FRAME MEMBERS FOR DAMAGE.

When Replacement Parts Are Needed, Order Only Yale® Factory Engineered Parts

HOW TO MEASURE WIRE ROPE

The correct diameter of a wire rope is the diameter of a circumscribed circle which will enclose all the strands. It is the largest cross-sectional measurement as illustrated below. The measurement should be made carefully with calipers. The illustrations below show the correct and incorrect method of measuring the diameter of wire rope.

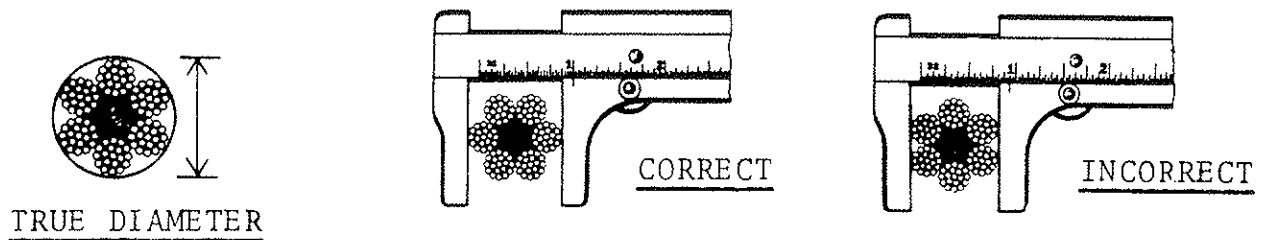

PROCEDURE FOR REEVING WIRE ROPE ON DRUM

NOTE UPPER AND LOWER LIMIT SWITCH MUST BE PRESET BEFORE REEVING, PER INSTRUCTIONSON PAGE 7 AND RE-ADJUSTED AFTER REEVING.

DOUBLE REEVED UNITS:

1. Anchor the rope in the drum on one side. Install rope retainer.
2. Stretch out rope to make sure there are no twists or kinks.
3. Reeve the free end of the rope through the bottom block and all sheaves. (See page 17.)
4. Anchor the free end of the rope in the other side of the drum. Install rope retainer.
5. Push the "UP" button to reeve both sides of the drum, making sure there is enough force on the rope to insure proper reeving in all drum grooves.

NOTE WHEN THE BOTTOM BLOCK IS RAISED TO THE UPPER LIMIT THE BLOCK SHOULD BE AT THE MID-POINT OF THE UNGROOVED PORTION OF THE DRUM AND EVEN WITH THE IDLER SHEAVE. IF THIS IS NOT SO, THE UNIT IS REEVED INCORRECTLY.

When Replacement Parts Are Needed, Order Only Yale® Factory Engineered Parts

SINGLE REEVED UNITS:

1. Anchor the rope in the drum. Install rope retainer.
2. Stretch out rope to make sure there are no twists or kinks.
3. Reeve the free end of the rope through the bottom block. (see next page.)
4. Attach the dead end of the rope to the suspension frame.
5. Push the "UP" button to reeve the drum making sure there is enough force on the rope to insure proper reeving in all drum grooves.



CAUTION

ALL UNITS MUST HAVE A MINIMUM OF 1 WRAP OF WIRE ROPE ON THE DRUM WHEN THE BOTTOM BLOCK IS IN THE LOWEST POSITION.

REEVING TYPES

Yale powered wire rope hoists and winches are reeved in various ways to gain desired advantages. Proper reeving insures maximum life of the hoist drum, wire rope and bottom block assembly while obtaining the best characteristics of capacity, lift and speed for the basic unit.

Reeving is either "single" or "double," i.e. one or two ropes coming from the drum. Standard headroom hoists are single reeved; close headroom hoists are double reeved. Part designates the mechanical use of each rope coming from the drum.

The table and drawings pictured on the next page show the characteristics of each principal method of reeving.

The advantages of single reeved units are fewer ropes and longer lifts from comparable units. Advantages of double reeved units include minimum lateral hook drift (keeping load in the same approximate position in relation to the drum and beam) and a lower hoist headroom requirement in certain configurations.

When Replacement Parts Are Needed, Order Only Yale® Factory Engineered Parts

SECTION B

REEVING TYPES

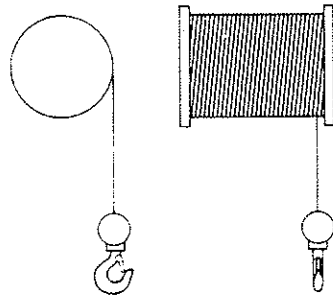

1 part single
S1

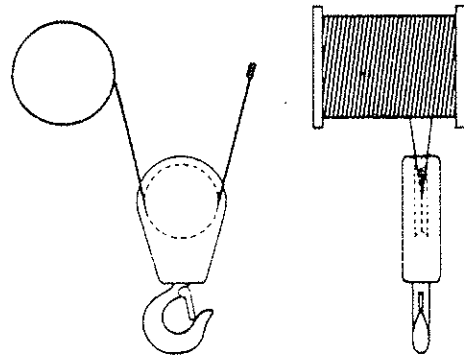

2 part single
S2

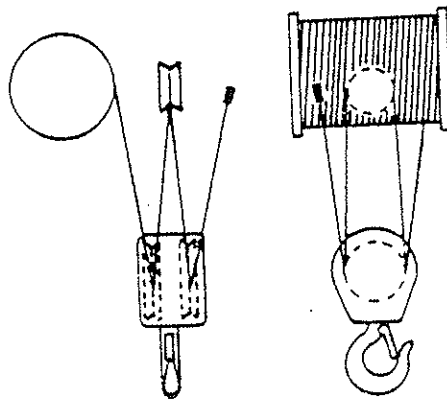

4 part single
S4

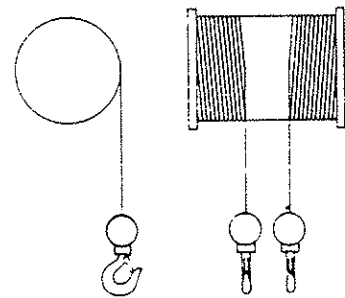

twin rope (1 part double)
D1

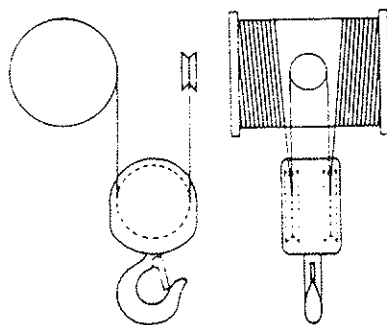

2 part double
D2

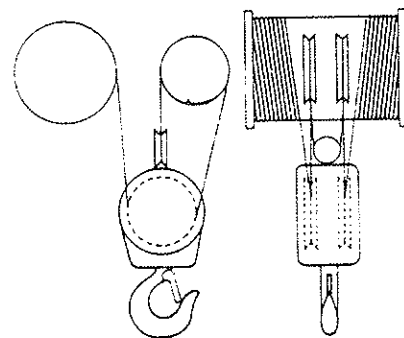

3 part double
D3

When Replacement Parts Are Needed, Order Only Yale® Factory Engineered Parts

SECTION B

DISASSEMBLY



CAUTION: BEFORE DOING MAINTENANCE WORK ON THIS HOIST, READ THE FOLLOWING INSTRUCTIONS THOROUGHLY. REFER TO THE REPLACEMENT PARTS SECTION FOR PARTS IDENTIFICATION.

To completely disassemble the hoist, follow the disassembly procedures in the order listed.

To disassemble any one specific part of the hoist, follow the instructions for that specific section.

DISASSEMBLY

I. Remove Hoist Rope, Bottom Block Or Bottom Hook

A. Standard Headroom Hoist

1. Remove or re-adjust upper and lower limit switch to negate lower limit [see instructions on page 7.]
2. Operate hoist in down direction until no cable remains on the drum. Remove rope retainers and pull rope sockets from the drum.
3. Remove power from the hoist.
4. Disassemble bottom block and remove hoist rope.
5. Remove pin holding the cable in the hoist frame.

B. Low Headroom Hoist

1. Follow procedures in I.A - 1, 2 and 3.
2. Remove pin holding equalizer sheave yoke in hoist frame.
3. Remove axle holding the sheave in the yoke and remove cable.

When Replacement Parts Are Needed, Order Only Yale® Factory Engineered Parts

REPAIR PARTS

DISASSEMBLY (Continued)

II. Remove Hoist Motor



CAUTION: CUT OFF ALL POWER TO THE HOIST BY DIS-CONNECTING THE POWER FEED LINE BEFORE ATTEMPTING SERVICE OR REPAIR.

1. Run hoist in lowering direction and clear all rope from the hoist drum.
2. Remove gear cover and remove snap ring around motor pinion bearing.
3. Pull out motor pinion with bearing attached.
4. Disconnect motor and motor brake leads
5. Support the weight of motor and brake assembly before proceeding.
6. Remove our (4) bolts under gear cover which hold the motor brake assembly to the frame end plate and pull assembly out of hoist frame. (With larger motors it may be necessary to also remove one of the frame brace bars to clear motor conduit box.)
7. Unbolt motor from brake assembly.

III. Remove Gearing

1. Loosen and remove four (4) nuts holding back bearing plate.
2. Remove back plate.
3. Remove snap rings to remove drum gear or motor pinion.

IV. Remove Hoist Brake

1. Run hoist in down direction and clear all rope from the hoist drum.
2. Remove motor and brake assembly as in procedure II.
3. Unbolt motor from brake assembly.

When Replacement Parts Are Needed, Order Only Yale® Factory Engineered Parts

SECTION B

DISASSEMBLY (Continued)

V. Remove Hoist Rope Drum

1. Follow procedures above to remove bottom block and rope assembly and to remove drum gear.
2. Remove upper and lower limit switch (located under the control cover).
3. Remove bolts holding frame end plates to the top suspension member, the 2 frame brace bars and the frame support plate.
4. Spread the sideplates to allow the drum to be removed.

VI. Remove Upper and Lower Limit Switch.

1. Disconnect all power from hoist.
2. Remove the control cover, disconnect the limit switch wiring. Note the color coding or tag the wires so they can be reconnected correctly.
3. Remove the two screws and lockwashers that hold the limit switch assembly to the mounting brackets. Carefully remove the limit switch assembly.

VII. Remove Controls

1. Remove all power from the hoist.
2. Remove control and cover. Disconnect and tag all wires coming into the control area.
3. Remove screws holding control panel on sideplate.
4. Remove control panel.

REASSEMBLY

The assembly sequence is basically the reverse of the disassembly sequence previously described. The following special instructions should be observed during reassembly:

1. Inspect the **drum support bearing** at both ends of the hoist drum. Replace if damaged.
2. Be sure the **motor brake** is properly adjusted before it is installed on the hoist. See Page 11.

When Replacement Parts Are Needed, Order Only Yale® Factory Engineered Parts

REPAIR PARTS

TROUBLE SHOOTING

UNIT NOISY

Possible Cause	Remedy
(a) Nicked gears.	(a) Examine teeth for nicks and burrs. Remove with honing stone, replace if teeth are severely damaged.
(b) No grease on gears.	(b) Apply grease to pinion and gear teeth.
(c) Defective bearing.	(c) Replace.

LOAD DRIFTS OR DROPS

Possible Cause	Remedy
(a) Brake slipping.	(e) Adjust brake. Check for oil on brake discs.
(b) Brake not closing.	(f) Adjust for proper clearance. (See Page 11).

BRAKE COIL BURNED OUT



CAUTION ALWAYS DISCONNECT POWER CIRCUIT BEFORE WORKING ON ELECTRICAL COMPONENTS.

Possible Cause	Remedy
(a) Wrong coil.	(a) Replace with proper voltage coil.
(b) Brake too tight.	(b) Adjust brake (See Section J).

When Replacement Parts Are Needed, Order Only Yale® Factory Engineered Parts

SECTION B

TROUBLE SHOOTING (Continued)

HOIST DOES NOT OPERATE

Possible Cause	Remedy
(a) Blown or loose fuse.	(a) Replace or tighten fuse.
(b) Tripped breaker.	(b) Reset breaker.
(c) Loose terminal screws.	(c) Check and tighten all loose screws.
(d) Low voltage.	(d) Check voltage at line side of reversing switch.
(e) Low voltage or no voltage to push button circuit.	(e) Check voltage at output side of transformer. Wrong voltage tap may have been selected. For example: 460 volt tap used when line voltage is 230 volt. Check control circuit fuse.
(f) Defective push button.	(f) Check contact points at push button to see if points touch. If not, replace.
(g) Defective push-button cord. (Wire may be pinched, broken or bare).	(g) Check for continuity of ground.
(h) Burned coil in reversing switch.	(h) Replace.
(i) Reversing switch plunger jammed in switch.	(i) Check for burned coil. Dis-assemble and replace defective components. Do not lubricate.
(j) Burned contact tips.	(j) Replace tips.
(k) Brake coil burned.	(k) Replace, check to make sure coil is proper coil for voltage applied.
(l) Defective stator.	(l) Rewind stator.
(m) Rotor loose on shaft.	(m) Reposition rotor and tack weld in place.

MOTOR OVERHEATS, EXCESSIVE AMPERAGE DRAW

Possible Cause	Remedy
(a) Defective stator.	(a) Replace or rewind stator.
(b) Worn motor bearings.	(b) Replace.
(c) Bent rotor shaft.	(c) Replace rotor shaft.
(d) Rotor dragging in stator.	(d) Tighten motor bolts. Check for foreign matter between rotor and stator. Check for worn motor bearings.
(e) Stator loose in frame.	(e) Rewind stator if necessary. Reposition and anchor in accordance with motor manufacturers instructions.

When Replacement Parts Are Needed, Order Only Yale® Factory Engineered Parts

TROUBLE SHOOTING (Continued)

MOTOR NOISY

Possible Cause	Remedy
(a) Motor bolts loose.	(a) Tighten.
(b) Rotor dragging in stator.	(b) Check for bent rotor shaft or worn bearings. Replace defective parts.
(c) Motor bearings loose.	(c) Replace bearings.

TRANSFORMER OVERHEATS OR BURNS OUT

Possible Cause	Remedy
(a) Wrong tap used on primary side.	(a) Replace transformer if necessary. Primary tap must match line voltage.
(b) Shorted transformer.	(b) Replace.
(c) Shorted control circuit.	(c) Correct short.

REVERSING SWITCH COIL BURNED OUT

Possible Cause	Remedy
(a) Wrong coil used.	(a) Replace coil. Be sure coil conforms to voltage of circuit it is used on.
(b) Jammed plunger.	(b) Disassemble and clean. Do not lubricate plunger or coil.
(c) Shorted coil.	(c) Replace.

HOIST SHOCKS OPERATOR

Possible Cause	Remedy
(a) Power leads or control wires shorted to hoist frame.	(a) Repair or replace.
(b) Grounded motor.	(b) Replace.
(c) Slight electrical leakage from any of the electrical components on hoist.	(c) Make sure hoist is properly grounded.
(d) Pendant diaphragm buttons have become cracked.	(d) Replace pendant.

When Replacement Parts Are Needed, Order Only Yale® Factory Engineered Parts

REPAIR PARTS

Recommended Spare Parts

PAGE NUMBER

1. Motor Brake Solenoid.	38
2. Contactor Magnetic Coils.	41
3. Contactor Parts Kit.	41
4. Wire Rope.	26
5. Hook Latch Kit.	27
6. Transformers.	42
7. Gasket.	26
8. Motor Brake Disc.	38

When Replacement Parts Are Needed, Order Only Yale® Factory Engineered Parts

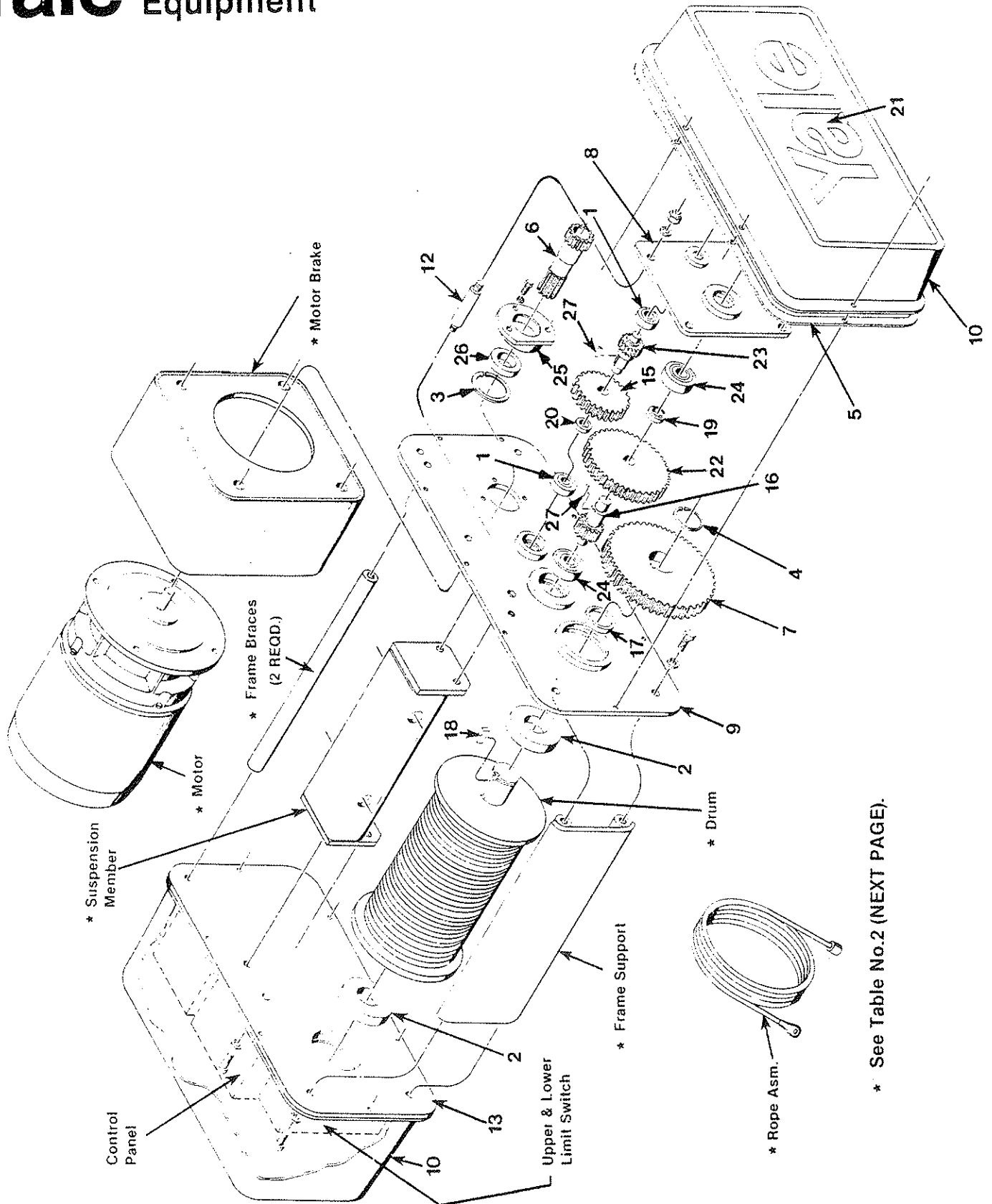

* See Table No.2 (NEXT PAGE).

When Replacement Parts Are Needed, Order Only Yale® Factory Engineered Parts

ITEM NO	PART NUMBER	DESCRIPTION	QTY.
1	0151204-00	BRG. BALL	2
2	6401629-03	BRG. BALL	2
3	0159173-00	RET. RING INT.	1
4	0533528-00	RET. RING EXT.	1
5	6456373-81	GASKET SELF ADH 1/4 X 5/8 FT	18
6	SEE TABLE 3	MOTOR PINION	1
7	6471183-00	DRUM GEAR	1
8	6471673-00	GEARCASE, BACK PLATE	1
9	6471653-00	SIDEPLATE, GEAR END	1
10	6472153-00	COVER	2
12	6472123-00	STAND-OFF	4
13	6461663-00	SIDEPLATE, CONTROL END	1
15	6493243-00	HIGH SPD. GEAR	1
16	6473253-00	SLOW SPEED PINION	1
17	6472053-01	SPACER, DRUM GEAR	1
18	6488144-01	KEY, DRUM GEAR	1
19	6472053-02	GEAR SPACER	1
20	6472053-03	GEAR SPACER	1
21	6476683-00	DECAL, (YALE CHALLENGER)	2
22	SEE TABLE 1	INTERMEDIATE GEAR	1
23	SEE TABLE 1	INTERMEDIATE PINION	1
24	0151294-00	BRG. BALL	2
25	6476193-00	BRG. CAP	1
26	0151275-00	BRG. BALL	1
27	5017079-08	WOODRUFF KEY	1

TABLE 1

RATIO	ITEM 22		ITEM 23	
	NO. TEETH	PART NO.	NO. TEETH	PART NO.
93.9:1	87	649326301	13	649323301
56.1:1	80	649326302	20	649323302
44.4:1	76	649326303	24	649323303

TABLE 3

ITEM 6	
1-SPD.	6476253-00
2-SPD.	6485723-00

TABLE 2

CAP	MODEL RYG.	LIFT	SUSP. MEMBER	FRAME SUPPORT	FRAME BRACES	DRUM	ROPE ASN	TROLLEY GEARED	TROLLEY PLAIN	TROLLEY MTG. KIT
1	S2	54	647190301	647184301	647173301	647261301	647078200	646982210	646982211	N/A
1	S2	76	647277303	637184302	647173302	647261301	647079200	644540201	644538201	647032200
2	S2	45	647190303	647184301	647173301	647262301	647080200	646982206	646982207	N/A
2	S2	63	647277302	647184302	647173302	647262302	647081200	644540201	644538201	647032200
2 1/2	S2	38	647190303	647184301	647173301	647182301	647082200	646982201	646982202	N/A
2 1/2	S2	53	647277302	647184302	647173302	647182302	644729203	644540201	644538201	647032200
3	S4	22	647192303	647184301	647173301	647262301	643535202	646982201	646982202	N/A
3	S4	32	647192304	647184302	647173302	647262302	647076200	646982201	646982202	N/A
5	S4	19	647192305	647184301	647173301	647182301	643536202	647030200	647031200	N/A
5	S4	26	647192306	647184302	647173302	647182302	647077200	647030200	647031200	N/A
7 1/2	S6	18	647193300	647184302	647173302	647182302	641131053	647044200	647045200	N/A
2	D2	32	647194300	647184302	647173302	647260302	647084200	646982206	646982207	N/A
2 1/2	D2	26	647194300	647184302	647173302	647227302	647085200	646982201	646982202	N/A

When Replacement Parts Are Needed, Order Only Yale® Factory Engineered Parts

Yale Hoisting Equipment

BOTTOM BLOCKS

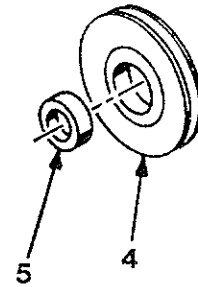
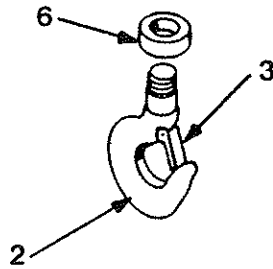
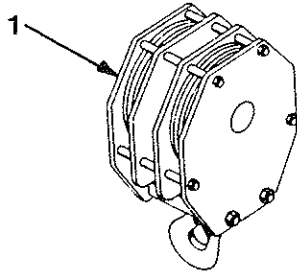

ITEM	1 TON S2	2 TON S2	2 ½ TON S2	3TON S4	5 TON S4	7 ½ TON S6	2 TON D2	2 ½ TON D2	DESCRIPTION
1A	060573900	059914700	647048201	010155201	643294200	647225301	010155700	647049201	COMP. ASM.-STD.
1B	641471200	641884000	647048202	643442201	643444200	647225302	503716000	647049202	COMP. ASM.-BRONZE
1C	649740000	643455200	647048203	500589001	643461200	647225303	643465200	647049203	COMP. ASM.-BULLARD
2A	643524300	643289300	644360400	644360400	644361400	644361400	643289300	644360400	HOOK-STD.
2B	644318300	066791500	643701300	643701300	642288100	642288100	066791500	643701300	HOOK-BRONZE
2C	645073400	644751400	644991400	644991400	645321400	645321400	644751400	644991400	HOOK-BULLARD
3A	066940200	066940300	066940600	066940600	066940600	066940600	066940300	066940600	LATCH KIT-STD.
3B	646254800	500690800	500695800	500695800	061667500	061667500	500690800	500695800	LATCH KIT-BRONZE
3C	N/A	N/A	N/A	N/A	N/A	N/A	N/A	N/A	LATCH KIT-BULLARD
4	010996500	059762400	010987801	010988501	010988500	010988500	010989200	010988501	SHEAVE
5	010080800	010078800	015128100	015128100	015128100	015128100	015128300	015128100	SHEAVE BRG.
6	010085200	022067700	646516800	646516800	033412000	033412000	022067700	646516800	HOOK THRUST BRG.

When Replacement Parts Are Needed, Order Only Yale® Factory Engineered Parts

REPAIR PARTS

REEVING KITS

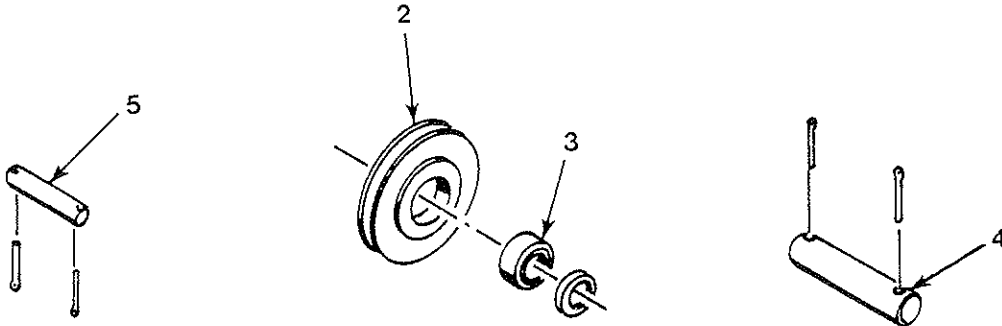

ITEM	DESCRIPTION	1 TON S2	2 TON S2	2-1/2 TON S2	3 TON S4	5 TON S4	7-1/2 TON S6	2 TON D2	2-1/2 TON D2
1	COMPLETE REEVING KIT	647120200	647121200	647121200	647747200	647748200	847057200	647047200	647047200
2	SHEAVE	-	-	-	010988501	010988500	010988500	647908100	647908100
3	SHEAVE BEARING	-	-	-	015128100	015128100	015128100	-	-
4	SHEAVE SHAFT	-	-	-	645203116	645203116	645203118	645407100	645407100
5	DEAD END PIN	644495107	644495108	644495108	647018304	647018304	647018304	-	-

When Replacement Parts Are Needed, Order Only Yale® Factory Engineered Parts

REPAIR PARTS

4 7/8" TREAD DIAMETER (NOMINAL)

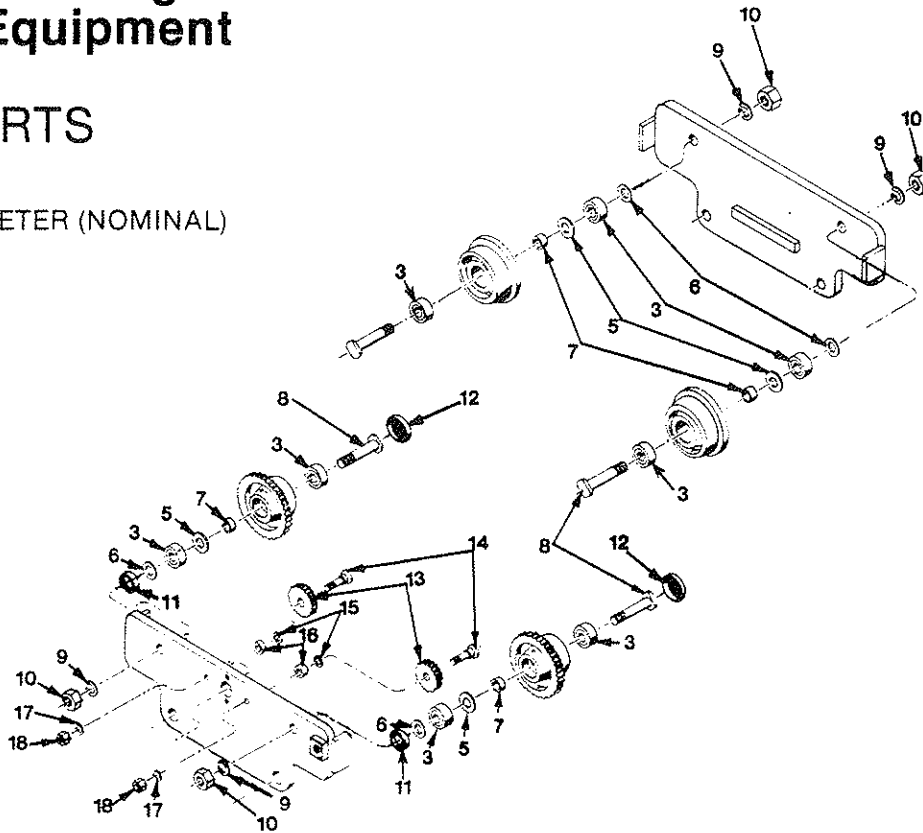

ITEM NUMBER	COMPONENT NUMBER	PART DESCRIPTION	QTY.
3	0641327-00	BEARING CONE	8
4	0641326-00	BEARING CUP	8
5	5024531-00	BEARING SHIM	16
6	0664040-00	BEARING SPACER	4
7	0664039-00	WHEEL SPACER	4
8	0664038-00	AXLE	4
9	0213606-00	AXLE NUT	4
13A	6456801-00	IDLER GEAR, STEEL (WHEN REQUIRED)	2
13B	6487501-00	IDLER GEAR, BRONZE (WHEN REQUIRED)	2
14	6400811-00	IDLER GEAR STUD (WHEN REQUIRED)	2

TREAD TYPE	WHEEL TYPE	BEAM TYPE	MATERIAL	WHEEL PART NUMBER
Ball	Plain	ASI	Standard	6412133-00
Ball	Geared	ASI	Standard	6412143-00
Ball	Geared	ASI	Bronze	6405663-00
Ball	Geared	ASI	Bronze	6405673-00
Flat	Plain	WF	Bronze	6450431-00
Flat	Geared	WF	Bronze	6450441-00
Flat	Plain	Pat. Track	Standard	6465981-00
Flat	Geared	Pat. Track	Standard	6465991-00
Flat	Plain	WF	Standard	6450411-00
Flat	Geared	WF	Standard	6450421-00
Flat	Plain	Pat. Track	Bronze	6468751-00
Flat	Geared	Pat. Track	Bronze	6468761-00

When Replacement Parts Are Needed, Order Only Yale Factory Engineered Parts.

REPAIR PARTS

6" TREAD DIAMETER (NOMINAL)

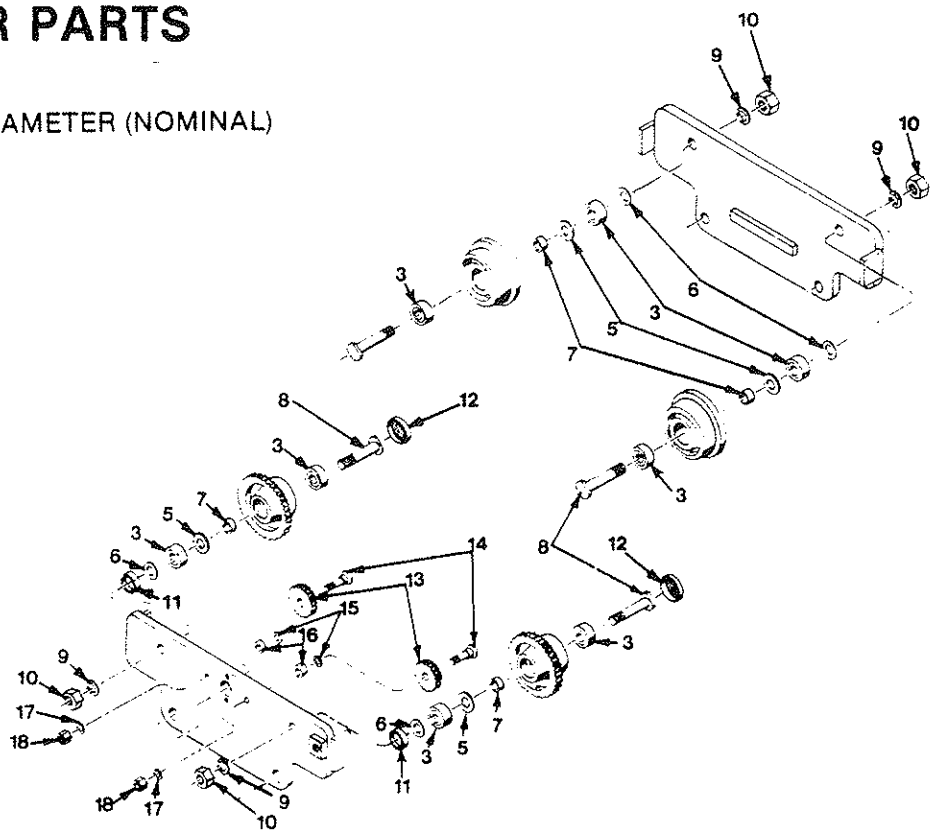

ITEM NUMBER	COMPONENT NUMBER	PART DESCRIPTION	QTY.
3	0578982-00	BEARING TAPERED	8
5	0111950-00	BEARING SHIM	16
6	0601083-00	BEARING SPACER	4
7	0579147-00	WHEEL SPACER	4
8	0664049-00	AXLE	4
9	0401010-00	LOCKWASHER 1 1/4	4
10	0379032-00	AXLE NUT	4
13A	0664433-00	IDLER GEAR, STEEL (WHEN REQUIRED)	2
13B	6421663-00	IDLER GEAR, BRONZE (WHEN REQUIRED)	2
14	6400811-00	IDLER GEAR STUD (WHEN REQUIRED)	2

TREAD TYPE	WHEEL TYPE	BEAM TYPE	MATERIAL	WHEEL PART NUMBER
Ball	Plain	ASI	Standard	6403844-00
Ball	Geared	ASI	Standard	6403854-00
Ball	Geared	ASI	Bronze	0664887-00
Ball	Geared	ASI	Bronze	0664886-00
Flat	Geared	Pat. Track	Standard	6454164-00
Flat	Plain	Pat. Track	Standard	6454154-00
Flat	Plain	WF	Bronze	6450471-00
Flat	Geared	WF	Bronze	6450481-00
Flat	Plain	WF	Standard	6450451-00
Flat	Geared	WF	Standard	6450461-00
Flat	Plain	Pat. Track	Bronze	6484291-00
Flat	Geared	Pat. Track	Bronze	6484211-00
Flat	Plain	Pat. Track	Standard	6454154-00
Flat	Geared	Pat. Track	Standard	6454164-00
Flat	Plain	Pat. Track	Bronze	6407373-00
Flat	Geared	Pat. Track	Bronze	6407383-00

When Replacement Parts Are Needed, Order Only Yale Factory Engineered Parts.

8" TREAD DIAMETER (NOMINAL)

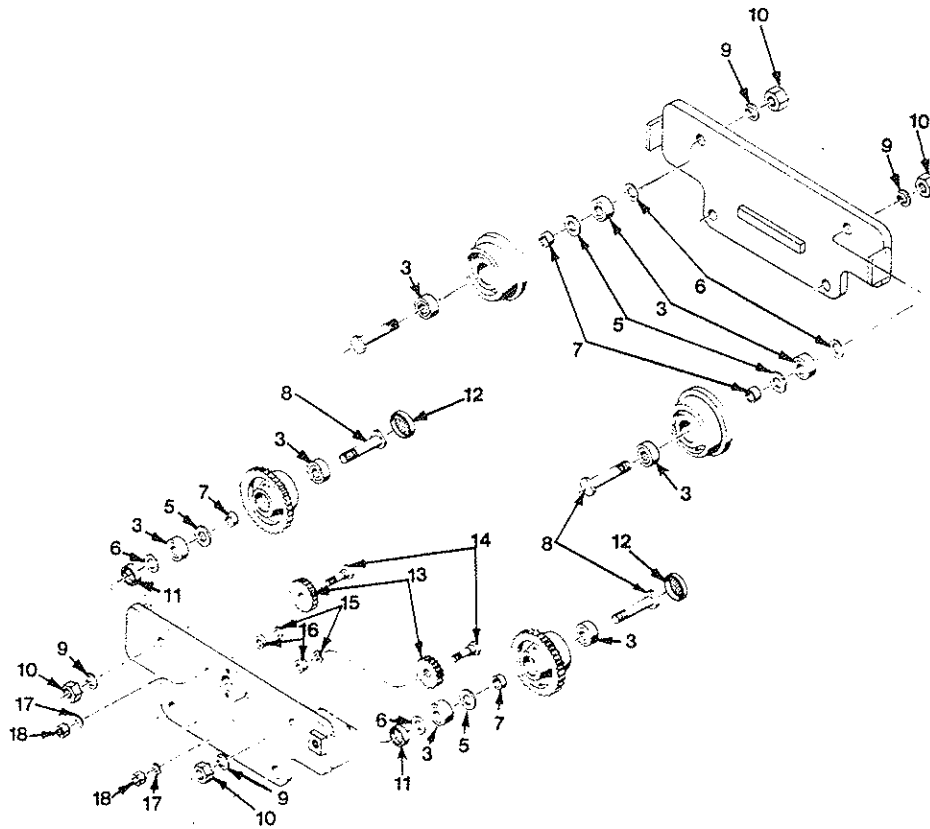

ITEM NUMBER	COMPONENT NUMBER	PART DESCRIPTION	QTY.
3	0646669-00	BEARING TAPERED	8
5	0111948-00	BEARING SHIM	16
6	0644668-00	BEARING SPACER	4
7	0236024-00	WHEEL SPACER	4
8	0664012-00	AXLE	4
9	0150300-00	LOCKWASHER 1 3/8	4
10	0149713-00	AXLE NUT 1 3/8 - 6	4
11	0646666-00	DUST COVER INSIDE	4
12	0646667-00	DUST COVER OUTSIDE	4
13A	0664821-00	IDLER GEAR, STEEL (WHEN REQUIRED)	2
13B	6490241-00	IDLER GEAR, BRONZE (WHEN REQUIRED)	2
14	0664826-00	IDLER GEAR STUD (WHEN REQUIRED)	2

TREAD TYPE	WHEEL TYPE	BEAM TYPE	MATERIAL	WHEEL PART NUMBER
Ball	Plain	ASI	Standard	6442494-00
Ball	Geared	ASI	Standard	6442504-00
Ball	Geared	ASI	Bronze	6404364-00
Ball	Geared	ASI	Bronze	6404374-00
Flat	Geared	WF	Standard	6433774-00
Flat	Plain	WF	Standard	6433764-00
Flat	Plain	Pat. Track	Standard	6446414-00
Flat	Geared	Pat. Track	Standard	6446424-00

When Replacement Parts Are Needed, Order Only Yale Factory Engineered Parts.

10" TREAD DIAMETER (NOMINAL)

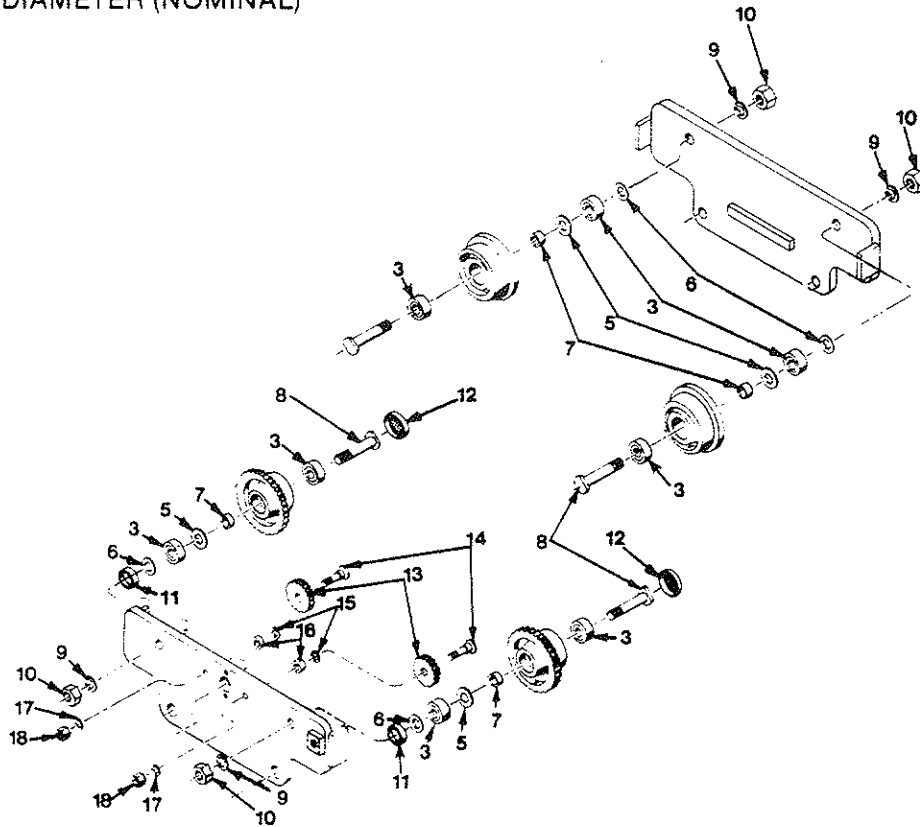

ITEM NUMBER	COMPONENT NUMBER	PART DESCRIPTION	QTY.
3	0651247-00	BEARING CONE	8
4	0651248-00	BEARING CUP	8
5	0651256-00	BEARING SHIM	16
6	0651249-00	BEARING SPACER	4
7	0651250-00	WHEEL SPACER	4
8	0651243-00	AXLE	4
9	5021379-02	LOCKWASHER	4
10	6401679-00	AXLE NUT	4
11	0651252-00	DUST COVER INSIDE	4
12	0651253-00	DUST COVER OUTSIDE	4
13A	0664821-00	IDLER GEAR, STEEL (WHEN REQUIRED)	2
13B	6490241-00	IDLER GEAR, BRONZE (WHEN REQUIRED)	2
14	0664826-00	IDLER GEAR STUD (WHEN REQUIRED)	2

TREAD TYPE	WHEEL TYPE	BEAM TYPE	MATERIAL	WHEEL PART NUMBER
Ball	Plain	ASI	Standard	0664017-00
Ball	Geared	ASI	Standard	0664432-00
Ball	Geared	ASI	Bronze	6426896-00
Ball	Geared	ASI	Bronze	6426906-00
Flat	Plain	WF	Standard	6450511-00
Flat	Geared	WF	Standard	6450521-00
Flat	Geared	Pat. Track	Standard	6473431-00
Flat	Plain	Pat. Track	Standard	6472651-00

When Replacement Parts Are Needed, Order Only Yale Factory Engineered Parts.

Yale Hoisting Equipment

REPAIR PARTS

TROLLEY HAND WHEEL GROUP

GT - GEARED TROLLEY

4 7/8" & 6" TREAD DIAMETER WHEELS

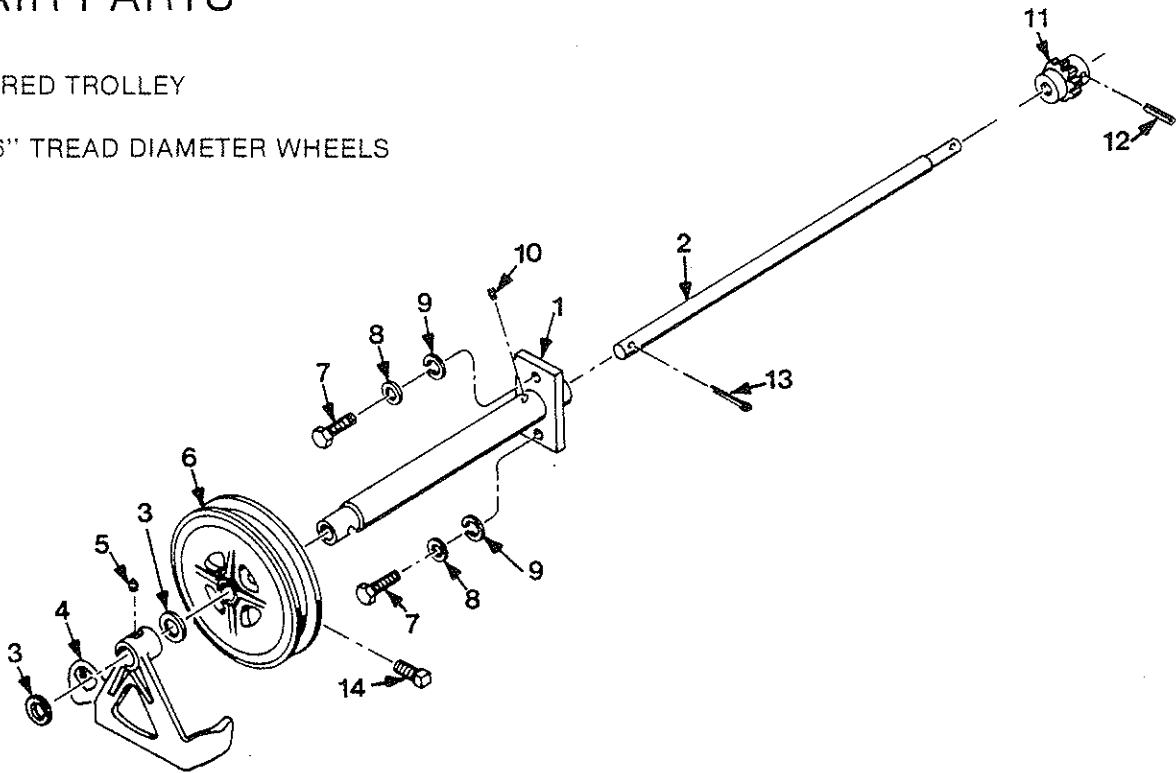

TABLE

4 7/8" TREAD DIAMETER WHEELS				
ASSEMBLY NUMBER	ITEM 1	ITEM 2	ITEM 11	ITEM 12
6434722-04	EXTENSION	SHAFT	PINION	ROLL PIN
	6452531-01	6456491-04	0250202-00	0230207-00

6" TREAD DIAMETER WHEELS				
ASSEMBLY NUMBER	ITEM 1	ITEM 2	ITEM 11	ITEM 12
6434732-05	EXTENSION	SHAFT	PINION	ROLL PIN
	6452881-02	6452891-02	0588168-00	0559292-00

ITEM NUMBER	PART NUMBER	DESCRIPTION	QTY.
3	0250668-00	WASHER	2
4	0588165-00	GUIDE	1
5	0156289-00	FITTING	1
6	0111132-00	HANDWHEEL	1
7	0554850-00	1/2-13 X 1 1/4 HEX HEAD SCREW	2
8	0142209-00	WASHER	2
9	0150266-00	LOCKWASHER	2
10	0227845-00	FITTING	1
13	0381400-00	COTTER PIN	1
14	0388054-00	7/16-14X1 SQUARE HEAD SCREW	1
15	0033730-00	HAND CHAIN (NOT SHOWN) SPECIFY LENGTH	

When Replacement Parts Are Needed, Order Only Yale Factory Engineered Parts.

TROLLEY HAND WHEEL GROUP

GT - GEARED TROLLEY

8 & 10" TREAD DIAMETER WHEELS

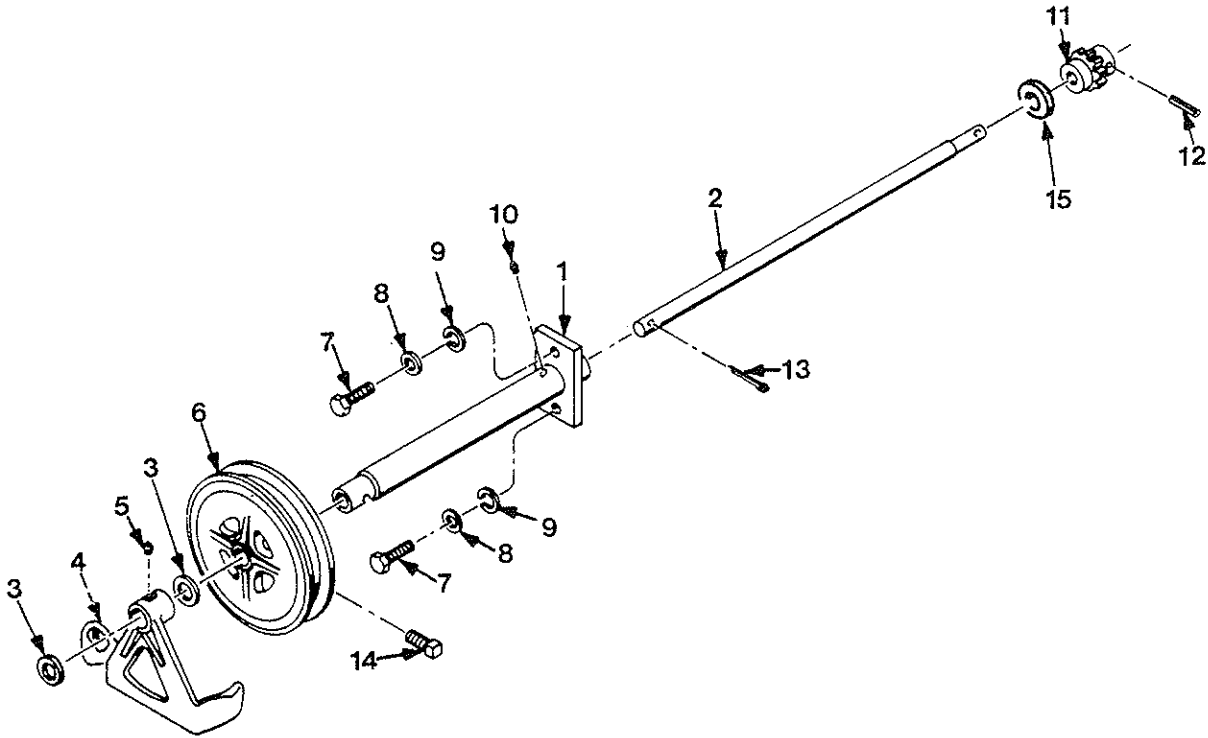

ASM. NUMBER 6434742-05

ITEM NUM	PART NUMBER	DESCRIPTION	QTY.
1	6467781-01	EXTENSION	1
2	6419981-03	SHAFT	1
3	0250664-00	WASHER	2
4	0591410-00	GUIDE	1
5	0156289-00	FITTING	1
6	0535795-00	HANDWHEEL	1
7	0596946-00	1/2 - 13 X 1 1/2 HEX HEAD SCREW	2
8	0142209-00	WASHER	2
9	0150266-00	LOCKWASHER	2
10	0227845-00	FITTING	1
11	0589690-00	PINION	1
12	0230236-00	ROLL PIN	1
13	0154214-00	COTTER PIN	1
14	0388014-00	1/2 - 13 SQUARE HEAD SCREW	1
15	0665193-00	SPACER	1
16	0033730-00	HAND CHAIN (NOT SHOWN) SPECIFY LENGTH	1

When Replacement Parts Are Needed, Order Only Yale Factory Engineered Parts.

Yale Hoisting Equipment

REPAIR PARTS

MOTORIZED TROLLEY DRIVE (RT)

Trolley Assembly
4 7/8" Tread Diameter

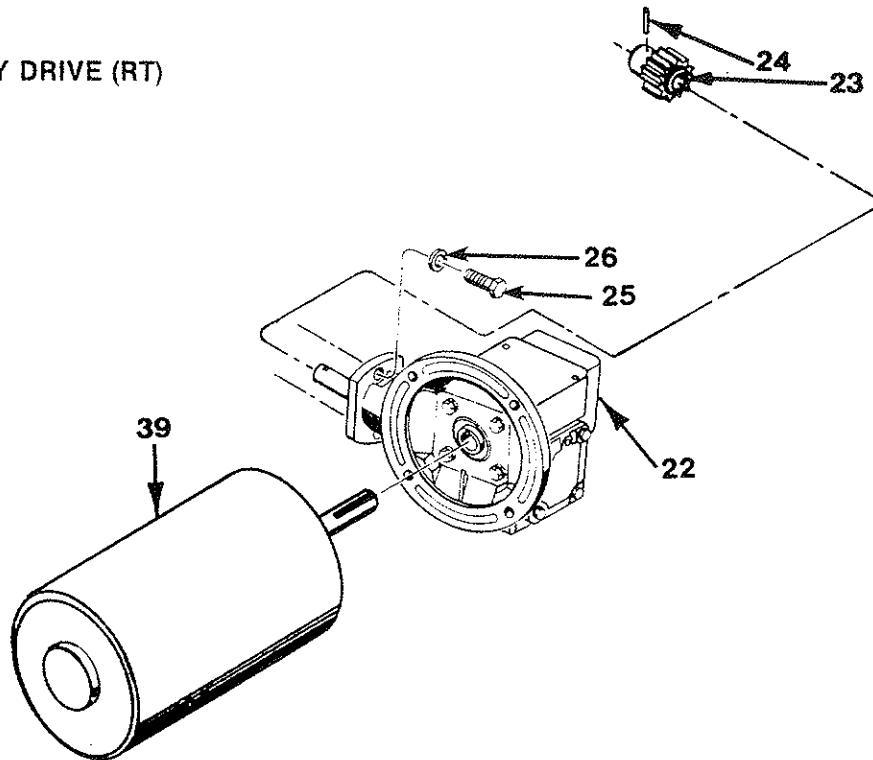

ITEM NBR	PART NUMBER	DESCRIPTION	QTY.
22	SEE TABLE 646700200	GEAR CASE RT MGT. KIT (Incl. Items 23, 24, 25 & 26)	1
23	6462883-00	PINION	1
24	6462973-01	GROOVE PIN	1
25	0554856-00	BOLT	2
26	0150266-00	LOCK WASHER	2
39	*	MOTOR	1

*When Ordering Motors Give Complete Data On Motor Nameplate.

GEAR TABLE

TRAVEL SPEED (FT/MIN)	GEAR CASE	RATIO
15	6462923-30	30:1
30	6462923-15	15:1
45	6462923-10	10:1
90	6462923-05	5:1

When Replacement Parts Are Needed, Order Only Yale® Factory Engineered Parts

REPAIR PARTS

MOTORIZED TROLLEY DRIVE (RT)

Trolley Assembly
6" Tread Diameter

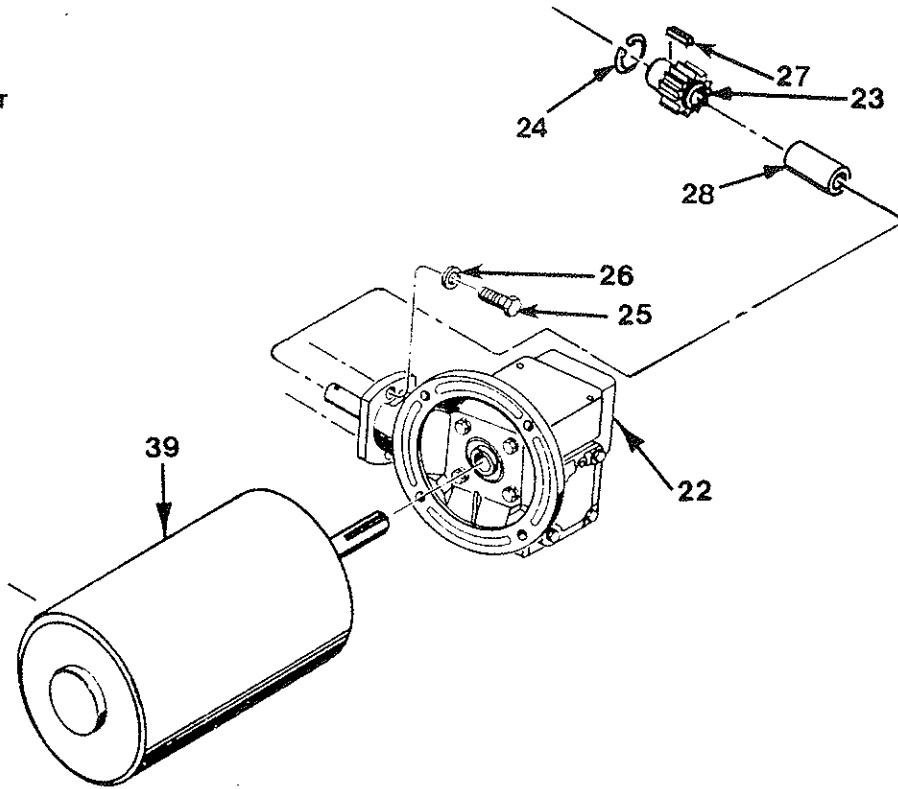

ITEM NBR	PART NUMBER	DESCRIPTION	QTY.
22	SEE TABLE 646701200	GEAR CASE RT MGT. KIT (Incl. Items 23 24, 25 & 26)	1
23	6462893-00	PINION	1
24	5002279-04	RETAINING RING	1
25	0554856-00	BOLT	2
26	0150266-00	LOCK WASHER	2
39	*	MOTOR	1
27	6462913-01	KEY	1
28	6457173-06	SPACER	1

*When Ordering Motors Give Complete Data On Motor Nameplate.

GEAR TABLE

TRAVEL SPEED (FT/MIN)	GEAR CASE	RATIO
15	6467093-06	40:1
30	6467093-04	20:1
45	6467093-03	15:1
65	6467093-02	10:1

When Replacement Parts Are Needed, Order Only Yale® Factory Engineered Parts

Yale Hoisting Equipment

REPAIR PARTS

MOTORIZED TROLLEY DRIVE (RT)

Trolley Assembly

8 & 10" Tread Diameter

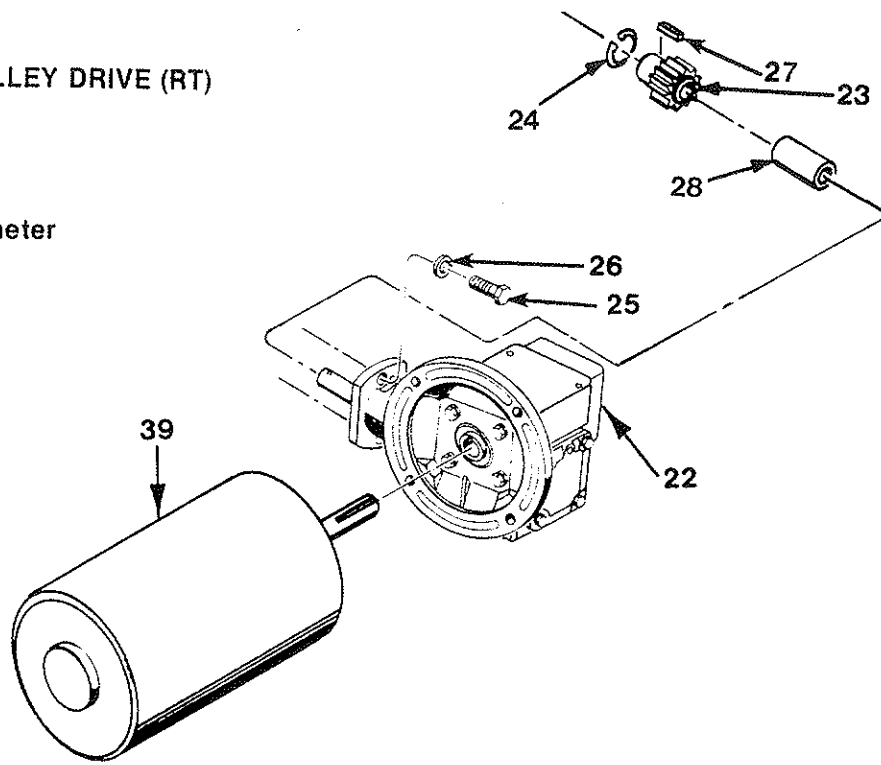

ITEM NBR	PART NUMBER	DESCRIPTION	QTY.
22	SEE TABLE 646702200	GEAR CASE	1
23	6462903-00	RT MGT. KIT (Incl. Items 23, 24, 25 & 26)	1
24	5002279-04	PINION	1
25	0554856-00	RETAINING RING	1
26	0150266-00	BOLT	2
27	0150266-00	LOCK WASHER	2
39	*	MOTOR	1
27	6462913-02	KEY	1
28	6457173-07	SPACER	1

*When Ordering Motors Give Complete Data On Motor Nameplate.

GEAR TABLE

TRAVEL SPEED (FT/MIN)	GEAR CASE	RATIO
15	6467093-06	40:1
30	6467093-04	20:1
45	6467093-03	15:1
65	6467093-02	10:1

When Replacement Parts Are Needed, Order Only Yale® Factory Engineered Parts

MOTOR BRAKE

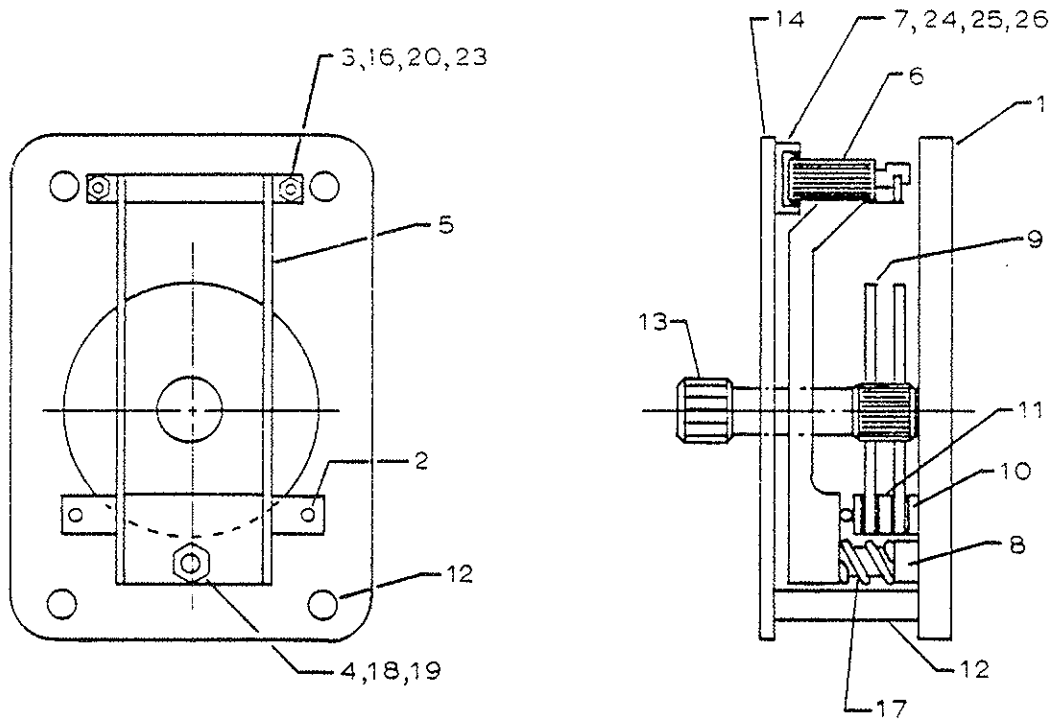





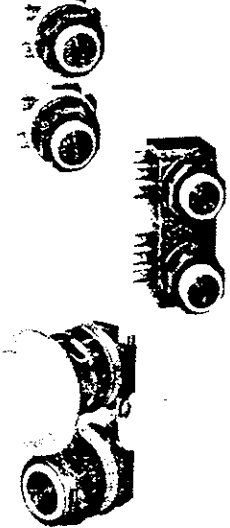

ITEM	P/N	QTY	DESCRIPTION
1	647232300	1	MTR. ADAPTER/BASE PLATE
2	647235300	2	GUIDE ROD
3	647236300	2	SPRING ROD
4	647234300	1	PIVOT POST
5	647894300	1	LEVER ASM.
6	647091202	SELECT	SOLENOID KIT 200V
	647091203	1	SOLENOID KIT 230V
	647091204		SOLENOID KIT 460V
	647091205		SOLENOID KIT 575V
7	647889300	1	SOLENOID BRACKET
8	647863300	1	SPACER, PIVOT POST
9	647141300	2	BRAKE PLATE
10	647249301	2	CALIPER ASM. (SINGLE)
11	647249302	1	CALIPER ASM. (DOUBLE)
12	647152300	4	STAND-OFF
13	647625300	1	INPUT PINION/BRAKE HUB
14	647374300	1	COVER PLATE
15	647056200	1	COVER ASM.
16	*	2	SPRING, 3 LG., SPRING ROD
17	*	1	SPRING, 2 1/2 LG., PIVOT POST
18	*	1	HEX JAM NUT, PIVOT POST
19	*	1	SPHERICAL NUT & WASHER, PIVOT POST
20	*	2	FLAT WASHER, SPRING ROD
21	*	2	HEX SCREW, SOL. BRKT.
22	*	2	LOCKWASHER, SOL. BRKT.
23	*	2	LOCKNUT, SPRING ROD
24	*	2	HEX SCREW, 2 1/4 LG., SOLENOID
25	*	8	SPACER, SOLENOID
26	*	2	LOCKNUT, ITEM 24

X HARDWARE KIT (647116200)

When Replacement Parts Are Needed, Order Only YALE[®] Factory Engineered Parts
 UEW SERIES 38 OCT 1985

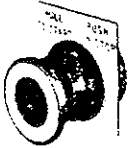
PUSH BUTTON

		Enclosure (Less) (Elements)	Two Button Four Button Six Button Eight Button Ten Button	6452753-02 6452753-04 6452753-06 6452753-08 6452753-10
	Elements		Single Speed (Pair)	6452763-01
			Two Speed (Pair)	6452763-02
			Five Speed (Pair)	6452763-05
			Maintained/ Momentary	6455953-00
		Selector Switch	Two Position Three Position	6463493-00 6455983-00
		Pilot Light	115 Volt Red	6455973-00
		Potentiometer	1000 Ohm	6451821-01
		Elements	Single Button (One)	6456263-00
		Off/On Element	Locking Non-Locking	6455963-00
		Closing Plate		6452883-00

When Replacement Parts Are Needed, Order Only Yale® Factory Engineered Parts



PUSH BUTTON

2760	Component Number	Markings				
		1	1A	1B	2	3
	6452803-01	Hoist			Up	Down
	6452803-02	Trolley			East	West
	6452803-03	Trolley			Forward	Reverse
	6452803-04	Trolley			North	South
	6452803-05	Bridge			Foward	Reverse
	6452803-06	Bridge			East	West
	6452803-07	Bridge			North	South
	6452803-08				Start	Stop
	6452803-09				Reset	Stop
	6452803-10					
	6452803-11				Foward	Reverse
	6452803-12				North	South
	6452803-13				East	West
	6452803-14				In	Out
	6452803-15				Left	Right
	6452803-16	Crane			Forward	Reverse
	6452803-17				Off	On
	6452803-18				On	Off
	6452803-19				Stop	Start
	6452803-20				Stop	Reset
	6452803-21			Inch		Run
	6452803-22			Slow		Fast

2710		Complete Station	Two Button	Up-Down	6480701-01
			S / Speed	Fwd- Rev	6480701-02
			Two Button	Up-Down	6469823-01
			Two Speed	Fwd-Rev	6469823-02
2710		COMPLETE STATION	TWO BUTTON S/SPEED	6471993-00	
2710		For Explosion Proof or other Special Push Buttons, Refer to Computer Parts list in front of Manual.			

When Replacement Parts Are Needed, Order Only Yale® Factory Engineered Parts

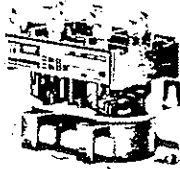
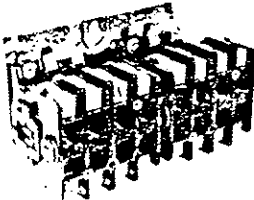
CONTACTOR

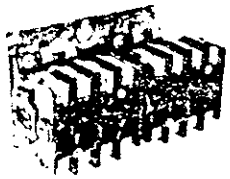
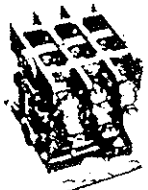
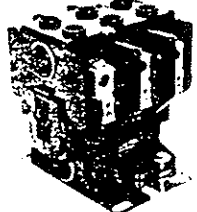
	COIL VOLTAGE	CONTACTOR PART NO.	COIL PART NO.	CONTACT KIT	AUXILIARY CONTACT
	24	6401559-01	5030618-00	6400028-00	6446608-01 (N.O.)
	115	6401559-02	5030628-00		6446608-02 (N.C.)
	24	6495701-01	6455871-11	6455871-10 (2) Req'd.	6424981-20
	115	6495701-02	6455871-12		
	24	6455808-01	6453168-00	6455898-00 (2) Req'd.	6453218-00 (N.O.)
	115	6455808-02	6453178-00		6453228-00 (N.C.)
	24	6424981-01	6424981-11	6424981-10 (2) Req'd.	6424981-20
	115	6424981-02	6424981-12		
	24	6455881-01	6455871-11	6455881-10	6424981-20
	115	6455881-02	6455871-12		
	24	6455891-01	6424981-01	6424981-10	6424981-20
	115	6455891-02	6424981-02		

When Replacement Parts Are Needed, Order Only Yale® Factory Engineered Parts

REPAIR PARTS

TRANSFORMER

TRANSFORMER NINE DIGIT PART NUMBER STAMPED HERE

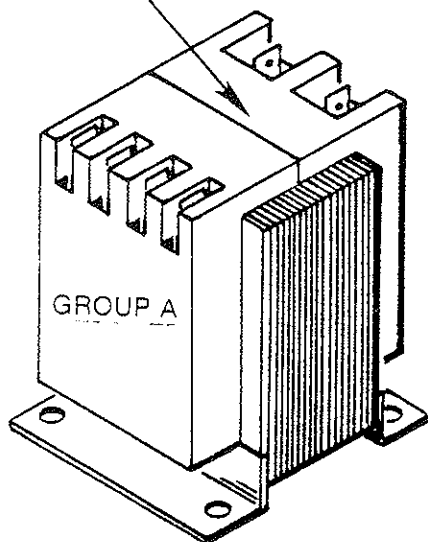

1. FIND VA, PRIMARY & SECONDARY VOLTS.
2. USE PARTS LIST IN FRONT COVER OR CHART TO SELECT TRANSFORMER

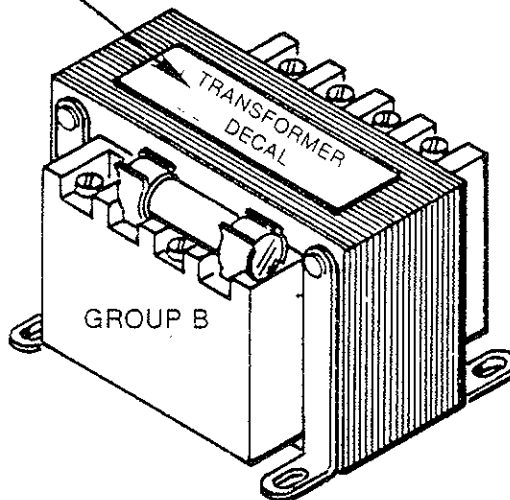

GROUP A

VA	Primary Volts	Secondary Volts	Hertz	Part Number	Replacement Fuse
25	115/230	24	50/60	6437393-01	N/R
	230/460	24	50/60	6437393-02	N/R
	115/230	110	50/60	6437393-03	N/R
	230/460	110	50/60	6437393-04	N/R
	200	24	50/60	6437393-05	N/R
	200	110	50/60	6437393-06	N/R
	575	24	50/60	6437393-07	N/R
	575	110	50/60	6437393-08	N/R

GROUP B (Including Fuse)

50	200	115	50/60	6437373-01	6458398-04
	230/460	115	50/60	6437373-02	6458398-04
	575	115	50/60	6437373-03	6458398-04
	200	24	50/60	6437373-04	6458398-11
	230/460	24	50/60	6437373-05	6458398-11
	575	24	50/60	6437373-06	6458398-11
150	200	115	50/60	6437373-07	6458398-08
	230/460	115	50/60	6437373-08	6458398-08
	575	115	50/60	6437373-09	6458398-08
	200	24	50/60	6437373-10	6458398-20
	230/460	24	50/60	6437373-11	6458398-20
	575	24	50/60	6437373-12	6458398-20
300	200	115	50/60	6437373-13	6458398-12
	230/460	115	50/60	6437373-14	6458398-12
	575	115	50/60	6437373-15	6458398-12
	200	24	50/60	6437373-16	6458398-25
	230/460	24	50/60	6437373-17	6458398-25
	575	24	50/60	6437373-18	6458398-25

N/R NOT REQUIRED

YA - 0383

FORM NO. 165-909-006

When Replacement Parts Are Needed, Order Only Yale® Factory Engineered Parts

REPAIR PARTS

THERMAL OVERLOAD HEATERS

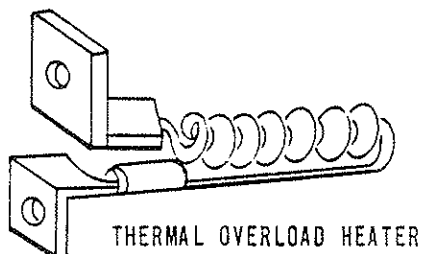

The Overload Heater Illustrated Above May Not Exactly Represent The Actual Appearance Of Your Overload Heater. However, It Is Typical.

Manufacturers Identification	Part Number	Full Load Amp Rating When Used In Overload Relay Number			
		6452508-00 (SEO—6B2) (3 Pole) Rating	6481811-01 (SEO—9B2) (3 Pole) Rating	0106755-00 0106756-00 (ARO—1) (1 Pole) Rating	(ATO—1) (1 Pole) Rating
AR .71	6400789-01	.52—.56		.56—.60	
AR .78	6400789-04	.57—.62		.61—.66	
AR 1.05	6400789-03	.77—.84		.82—.89	
AR 1.15	0579103-00	.85—.92		.90—.98	
AR 1.26	0106784-00	.93—1.01		.99—1.08	
AR 1.39	6400789-07	1.02—1.12		1.09—1.19	
AR 1.53	0106775-00	1.13—1.23		1.20—1.31	
AR 1.68		1.24—1.35		1.32—1.45	
AR 1.85	0106772-00	1.36—1.50		1.46—1.60	
AR 2.04	0106787-00	1.51—1.65		1.61—1.76	
AR 2.24	0106776-00	1.66—1.81		1.77—1.93	
AR 2.46	6400789-02	1.82—1.99		1.94—2.13	
AR 2.71	0106782-00	2.00—2.19		2.14—2.34	
AR 2.98	0546128-00	2.20—2.41		2.35—2.58	
AR 3.28	0106770-00	2.42—2.67		2.59—2.85	
AR 3.62	0106778-00	2.68—2.93		2.86—3.13	
AR 3.98	6400789-06	2.94—3.22		3.14—3.44	
AR 4.37	0560153-00	3.23—3.54		3.45—3.78	

FORM NO. 165-909-013

When Replacement Parts Are Needed, Order Only Yale® Factory Engineered Parts

REPAIR PARTS

THERMAL OVERLOAD HEATERS

Manufacturers Identification	Part Number	Full Load Amp Rating When Used in Overload Relay Number			
		6452508-00 (SEO—6B2) (3 Pole) Rating	6481811-01 (SEO—9B2) (3 Pole) Rating	0106755-00 0106756-00 (ARO—1) (1 Pole) Rating	(ATO—1) (1 Pole) Rating
AR 4.80	6400789-05	3.55—3.91		3.79—4.17	
AR 5.3	0106783-00	3.92—4.28		4.18—4.57	
AR 5.8	0106771-00	4.29—4.72		4.58—5.04	
AR 6.4	0586636-00	4.73—5.17		5.05—5.52	
AR 7.0	0106779-00	5.18—5.68		5.53—6.07	
AR 7.7	0106762-00	5.69—6.28		6.08—6.70	
AR 8.5	0106768-00	6.29—6.87		6.71—7.33	
AR 9.3	0106769-00	6.88—7.54	5.11—5.60	7.34—8.05	7.34—8.05
AR 10.2	0106767-00	7.55—8.28	5.61—6.15	8.06—8.84	8.06—8.84
AR 11.2	0106781-00	6.29—9.16	6.16—6.81	8.85—9.78	8.85—9.78
AR 12.4	0106774-00	9.17—9.99	6.82—7.47	9.79—10.6	9.79—10.6
AR 13.6	0106766-00	10.0 —11.3	7.48—8.47	10.7 —12.0	10.7 —12.0
AR 15.4	0106785-00	11.4 —12.9	8.47—9.67	12.1 —13.8	12.1 —13.8
AR 17.6	0106763-00	13.0 —15.1	9.68—11.2	13.9 —16.1	13.9 —16.1
AR 20.5	0106777-00	15.2 —16.9	11.3—12.5	16.2 —18.1	16.2 —18.1
AR 23.	0106764-00	17.0 —19.9	12.6—14.8	18.2 —21.2	18.2 —21.2
AR 27.	0106765-00	20.0 —22.1	14.9—16.4	21.3 —23.6	21.3 —23.6
AR 30.	0106768-00	22.2 —24.8	16.5 —19.1	23.7 —27.5	23.7 —27.5
AR 35.	0106780-00	25.9 —28.5	19.2 —21.9	27.6 —31.5	27.6 —31.5
AR 40.	0547894-00	29.6 —31.5	22.0 —23.1		31.6 —33.6
AR 44.	6466548-00		24.2 —25.7		34.7 —37.0
AR 47.			25.8 —27.9		37.1 —40.2
AR 51.	0548711-00		28.0 —30.1		40.3 —43.3
AR 55.	0594821-00		30.2 —32.9		43.4 —47.3
AR 60.			33.0 —36.2		47.4 —52.0
AR 66.			36.3 —39.5		
AR 72.			39.6 —43.3		
AR 79.			43.4 —47.2		
AR 86.			47.3 —51.6		
AR 94.			51.7 —55.0		

NO.09-013

FORM NO. 165-909-013

When Replacement Parts Are Needed, Order Only Yale® Factory Engineered Parts

POWERED HOIST INSPECTION CHECK LIST

SEE PREVENTIVE MAINTENANCE SECTION OF INSTRUCTION MANUAL FOR DETAILS.

CHECK ONLY COMPONENTS APPLICABLE FOR SPECIFIC EQUIPMENT AND INSPECTION TYPE.

HOIST MODEL _____

HOIST S/N _____

HOOKS	YES	NO	CABLE	YES	NO	CHAINS	YES	NO
HARDWARE LOOSE	<input type="checkbox"/>	<input type="checkbox"/>	BROKEN WIRES AT ENDS	<input type="checkbox"/>	<input type="checkbox"/>	BINDING	<input type="checkbox"/>	<input type="checkbox"/>
CRACKS	<input type="checkbox"/>	<input type="checkbox"/>	BROKEN WIRES EXCESSIVE	<input type="checkbox"/>	<input type="checkbox"/>	CRACKED	<input type="checkbox"/>	<input type="checkbox"/>
EXCESSIVE WEAR	<input type="checkbox"/>	<input type="checkbox"/>	EXCESSIVE WEAR	<input type="checkbox"/>	<input type="checkbox"/>	TWISTED	<input type="checkbox"/>	<input type="checkbox"/>
BENT	<input type="checkbox"/>	<input type="checkbox"/>	KINKED OR DISTORTED	<input type="checkbox"/>	<input type="checkbox"/>	DISTORTED	<input type="checkbox"/>	<input type="checkbox"/>
SPREADING	<input type="checkbox"/>	<input type="checkbox"/>	CORROSION	<input type="checkbox"/>	<input type="checkbox"/>	CORRODED	<input type="checkbox"/>	<input type="checkbox"/>
FREELY ROTATE	<input type="checkbox"/>	<input type="checkbox"/>	HEAT DAMAGED	<input type="checkbox"/>	<input type="checkbox"/>	EXCESSIVE WEAR	<input type="checkbox"/>	<input type="checkbox"/>
LATCH DAMAGED	<input type="checkbox"/>	<input type="checkbox"/>				WORN CHAIN GUIDES	<input type="checkbox"/>	<input type="checkbox"/>
						POCKET WHEELS WORN	<input type="checkbox"/>	<input type="checkbox"/>
BRAKES			WIRING			DRUM & SHEAVES		
MOTOR BRAKE WORN OR NOT OPERATING	<input type="checkbox"/>	<input type="checkbox"/>	LOOSE CONNECTIONS	<input type="checkbox"/>	<input type="checkbox"/>	WORN EXCESSIVELY	<input type="checkbox"/>	<input type="checkbox"/>
EXCESSIVE LOADBRAKE DRIFT OR BLACKLASH	<input type="checkbox"/>	<input type="checkbox"/>	FRAYED	<input type="checkbox"/>	<input type="checkbox"/>	CRACKED OR SCORED	<input type="checkbox"/>	<input type="checkbox"/>
EXCESSIVE DISC WEAR	<input type="checkbox"/>	<input type="checkbox"/>	DAMAGED	<input type="checkbox"/>	<input type="checkbox"/>			
			PROPER GROUNDING	<input type="checkbox"/>	<input type="checkbox"/>			
LIMIT SWITCHES			LOAD LIMITING DEVICE			COLLECTORS		
OPERATING PROPERLY	<input type="checkbox"/>	<input type="checkbox"/>	OPERATING PROPERLY	<input type="checkbox"/>	<input type="checkbox"/>	BINDING	<input type="checkbox"/>	<input type="checkbox"/>
						EXCESSIVE WEAR	<input type="checkbox"/>	<input type="checkbox"/>
HOUSING			OPERATION CONTROLS			LUBRICATION		
DISTORTED	<input type="checkbox"/>	<input type="checkbox"/>	CONTACTOR PITTING	<input type="checkbox"/>	<input type="checkbox"/>	ALL POINTS LUBRICATED AS GIVEN IN LUB CHART	<input type="checkbox"/>	<input type="checkbox"/>
CRACKS	<input type="checkbox"/>	<input type="checkbox"/>	OPERATING PROPERLY	<input type="checkbox"/>	<input type="checkbox"/>	OIL DARK OR LOW	<input type="checkbox"/>	<input type="checkbox"/>
LOOSE HARDWARE	<input type="checkbox"/>	<input type="checkbox"/>	DAMAGED PUSH BUTTON	<input type="checkbox"/>	<input type="checkbox"/>	OIL LEAKS	<input type="checkbox"/>	<input type="checkbox"/>
BEARING NOISE	<input type="checkbox"/>	<input type="checkbox"/>	HOUSING	<input type="checkbox"/>	<input type="checkbox"/>			
SUPPORTING STRUCTURE			AIR SYSTEM			WARNING LABELS		
CONTINUED ABILITY TO SUPPORT IMPOSED LOADS	<input type="checkbox"/>	<input type="checkbox"/>	LEAKING	<input type="checkbox"/>	<input type="checkbox"/>	MISSING	<input type="checkbox"/>	<input type="checkbox"/>
WORN OR DISTORTED TROLLEY PARTS	<input type="checkbox"/>	<input type="checkbox"/>	LOOSE CONNECTIONS	<input type="checkbox"/>	<input type="checkbox"/>	ILLEGIBLE	<input type="checkbox"/>	<input type="checkbox"/>
			BROKEN CONTROL PENDANT	<input type="checkbox"/>	<input type="checkbox"/>			

NOTE: IF ANY () IS CHECKED DO NOT OPERATE THE HOIST UNTIL REPAIRS HAVE BEEN MADE.

REMARKS AND REPAIRS MADE _____

SIGNATURE _____ DATE _____ CLOCK NUMBER _____

POWERED HOIST INSPECTION CHECK LIST

SEE PREVENTIVE MAINTENANCE SECTION OF INSTRUCTION MANUAL FOR DETAILS.

CHECK ONLY COMPONENTS APPLICABLE FOR SPECIFIC EQUIPMENT AND INSPECTION TYPE.

HOIST MODEL _____

HOIST S/N _____

HOOKS	YES	NO	CABLE	YES	NO	CHAINS	YES	NO
HARDWARE LOOSE	<input type="checkbox"/>	<input type="checkbox"/>	BROKEN WIRES AT ENDS	<input type="checkbox"/>	<input type="checkbox"/>	BINDING	<input type="checkbox"/>	<input type="checkbox"/>
CRACKS	<input type="checkbox"/>	<input type="checkbox"/>	BROKEN WIRES EXCESSIVE	<input type="checkbox"/>	<input type="checkbox"/>	CRACKED	<input type="checkbox"/>	<input type="checkbox"/>
EXCESSIVE WEAR	<input type="checkbox"/>	<input type="checkbox"/>	EXCESSIVE WEAR	<input type="checkbox"/>	<input type="checkbox"/>	TWISTED	<input type="checkbox"/>	<input type="checkbox"/>
BENT	<input type="checkbox"/>	<input type="checkbox"/>	KINKED OR DISTORTED	<input type="checkbox"/>	<input type="checkbox"/>	DISTORTED	<input type="checkbox"/>	<input type="checkbox"/>
SPREADING	<input type="checkbox"/>	<input type="checkbox"/>	CORROSION	<input type="checkbox"/>	<input type="checkbox"/>	CORRODED	<input type="checkbox"/>	<input type="checkbox"/>
FREELY ROTATE	<input type="checkbox"/>	<input type="checkbox"/>	HEAT DAMAGED	<input type="checkbox"/>	<input type="checkbox"/>	EXCESSIVE WEAR	<input type="checkbox"/>	<input type="checkbox"/>
LATCH DAMAGED	<input type="checkbox"/>	<input type="checkbox"/>				WORN CHAIN GUIDES	<input type="checkbox"/>	<input type="checkbox"/>
						POCKET WHEELS WORN	<input type="checkbox"/>	<input type="checkbox"/>
BRAKES			WIRING			DRUM & SHEAVES		
MOTOR BRAKE WORN OR NOT OPERATING	<input type="checkbox"/>	<input type="checkbox"/>	LOOSE CONNECTIONS	<input type="checkbox"/>	<input type="checkbox"/>	WORN EXCESSIVELY	<input type="checkbox"/>	<input type="checkbox"/>
EXCESSIVE LOADBRAKE DRIFT OR BLACKLASH	<input type="checkbox"/>	<input type="checkbox"/>	FRAYED	<input type="checkbox"/>	<input type="checkbox"/>	CRACKED OR SCORED	<input type="checkbox"/>	<input type="checkbox"/>
EXCESSIVE DISC WEAR	<input type="checkbox"/>	<input type="checkbox"/>	DAMAGED	<input type="checkbox"/>	<input type="checkbox"/>			
			PROPER GROUNDING	<input type="checkbox"/>	<input type="checkbox"/>			
LIMIT SWITCHES			LOAD LIMITING DEVICE			COLLECTORS		
OPERATING PROPERLY	<input type="checkbox"/>	<input type="checkbox"/>	OPERATING PROPERLY	<input type="checkbox"/>	<input type="checkbox"/>	BINDING	<input type="checkbox"/>	<input type="checkbox"/>
						EXCESSIVE WEAR	<input type="checkbox"/>	<input type="checkbox"/>
HOUSING			OPERATION CONTROLS			LUBRICATION		
DISTORTED	<input type="checkbox"/>	<input type="checkbox"/>	CONTACTOR PITTING	<input type="checkbox"/>	<input type="checkbox"/>	ALL POINTS LUBRICATED AS GIVEN IN LUB CHART	<input type="checkbox"/>	<input type="checkbox"/>
CRACKS	<input type="checkbox"/>	<input type="checkbox"/>	OPERATING PROPERLY	<input type="checkbox"/>	<input type="checkbox"/>	OIL DARK OR LOW	<input type="checkbox"/>	<input type="checkbox"/>
LOOSE HARDWARE	<input type="checkbox"/>	<input type="checkbox"/>	DAMAGED PUSH BUTTON	<input type="checkbox"/>	<input type="checkbox"/>	OIL LEAKS	<input type="checkbox"/>	<input type="checkbox"/>
BEARING NOISE	<input type="checkbox"/>	<input type="checkbox"/>	HOUSING	<input type="checkbox"/>	<input type="checkbox"/>			
SUPPORTING STRUCTURE			AIR SYSTEM			WARNING LABELS		
CONTINUED ABILITY TO SUPPORT IMPOSED LOADS	<input type="checkbox"/>	<input type="checkbox"/>	LEAKING	<input type="checkbox"/>	<input type="checkbox"/>	MISSING	<input type="checkbox"/>	<input type="checkbox"/>
WORN OR DISTORTED TROLLEY PARTS	<input type="checkbox"/>	<input type="checkbox"/>	LOOSE CONNECTIONS	<input type="checkbox"/>	<input type="checkbox"/>	ILLEGIBLE	<input type="checkbox"/>	<input type="checkbox"/>
			BROKEN CONTROL PENDANT	<input type="checkbox"/>	<input type="checkbox"/>			

NOTE: IF ANY (☐) IS CHECKED DO NOT OPERATE THE HOIST UNTIL REPAIRS HAVE BEEN MADE.

REMARKS AND REPAIRS MADE _____

SIGNATURE _____ DATE _____ CLOCK NUMBER _____

Yale® Hoists Warranty

Yale

Warranty

Every hoist is thoroughly inspected and tested prior to shipment from the factory. Should any problems develop, return the complete hoist prepaid to your nearest Yale Authorized Warranty Repair Station.

This warranty does not apply where: (1) deterioration is caused by normal wear, abuse, improper or inadequate power supply, eccentric or side loading, overloading, chemical or abrasive actions, improper maintenance or excessive heat; (2) problems resulted from repairs, modifications or alterations made by persons other than factory or Duff-Norton personnel;

(3) the hoist has been abused or damaged as a result of an accident; (4) repair parts or accessories other than those supplied by Duff Norton are used on the hoist. Equipment and accessories not of the seller's manufacture are warranted only to the extent that they are warranted by the manufacturer. EXCEPT AS STATED HEREIN, DUFF-NORTON MAKES NO OTHER WARRANTIES, EXPRESS OR IMPLIED, INCLUDING WARRANTIES OF MERCHANTABILITY AND FITNESS FOR A PARTICULAR PURPOSE.

Improvements:

Yale is constantly striving to improve its product. Changes in design and improvements will be made whenever manufacturer believes the efficiency of the product will be improved without incurring any obligation to incorporate such improvements in any products which have been shipped or are in service.

Important Notice:

Use of chain, wire rope or replacement parts other than as supplied as original equipment on Yale hoists may lead to dangerous operation. Accordingly, Yale cannot be responsible in such cases and our warranty should be voided.

For more information write Yale Hoists, Forrest City, Arkansas 72335.

ALL SHIPMENTS SUBJECT TO CHANGE WITHOUT NOTICE AND MAY BE ADJUSTED TO SELLER'S PRICE IN EFFECT AT TIME OF SHIPMENT.
THIS CANCELS AND SUPERSEDES ALL PREVIOUS PRICES.
ALL PRICES IN U.S. DOLLARS.



Yale® Hoists
Highway 1 North
P.O. Box 1000
Forrest City, Arkansas 72335
Customer Service Phone (800) 999-6318
Fax (800) 766-0223

Copyright 1990
Yale Hoists

3105U 11M7 90