

**CA SERIES
AIR POWERED HOISTS**

Parts and Instruction
Manual

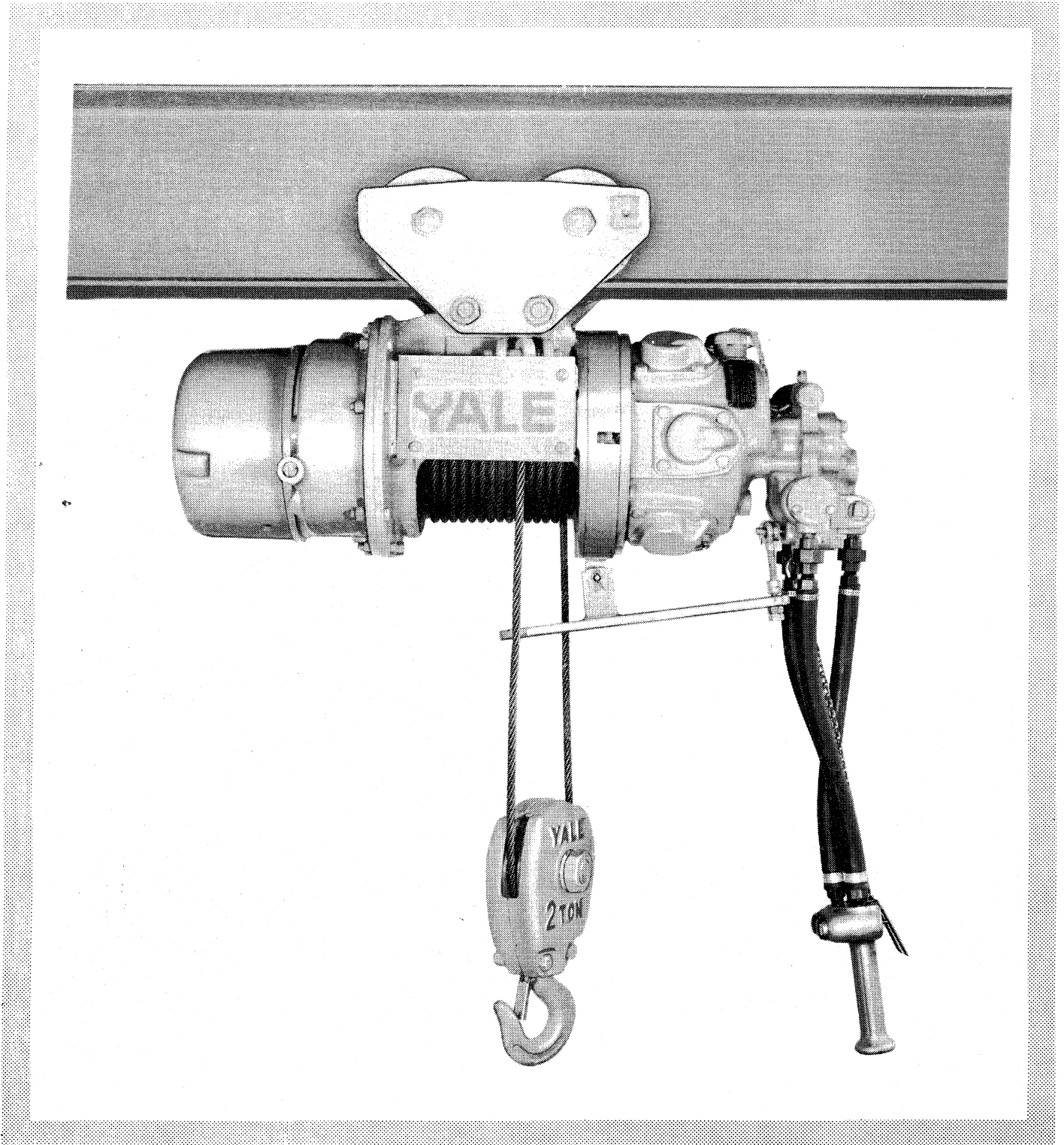

HOIST SERIAL NUMBER _____
TROLLEY SERIAL NUMBER _____
YALE ORDER NUMBER _____
CUSTOMER ORDER NUMBER _____



SECTION A

SAFETY



Yale

SAFE HOISTING PRACTICES

For your own safety and that of your fellow workers, Material Handling Equipment must be used as recommended by the manufacturer. Failure to heed the following recommendations could endanger your life.

1. Never pick up a load beyond the rated capacity appearing on the hoist.
2. Never carry personnel on the hook or the load.
3. Never lift a load with the hoist until all personnel are clear.
4. Never use the hoist rope or chain as a sling.
5. Do not allow unqualified personnel to operate the hoist.
6. Do not transport load over personnel.
7. Do not use the chain or rope as a ground for welding.
8. Never touch the welding electrode to the chain or rope.
9. Do not use safety upper limit switch as a means of stopping the hoist. This is an emergency device only.
10. Do not leave a load suspended in the air for extended or unattended periods.
11. Center hoist unit over the load before lifting. Avoid side pull.
12. Be sure the sling is properly seated in the saddle of the hook.
13. Make sure a load clears neighboring stock piles or machinery before moving.
14. Avoid plugging, excessive inching and quick reversals of load.
15. Avoid swinging of load or load hook when traveling the hoist.
16. Check limit devices and braking mechanism daily for proper function. Check daily the wire rope or chain for improper seating, twisting, kinking, wear or other defects before operating the hoist.
17. Be sure that the power supply is disconnected before performing maintenance and repair procedure.

When Replacement Parts Are Needed, Order Only YALE[®] Factory Engineered Parts



- TABLE OF CONTENTS -

	Page
GENERAL INSTALLATION INSTRUCTIONS.....	1
1. General Installation Instructions.....	1
2. Motor Maintenance.....	2
3. Repair Parts Ordering Information.....	3
PERIODIC INSPECTION AND PREVENTIVE MAINTENANCE.....	4
1. Lubrication.....	4
2. Preventive Maintenance Schedule.....	4
OPERATING AND MAINTENANCE INSTRUCTIONS FOR TROLLEY MOTOR.....	6
1. Construction.....	6
2. Installation.....	6
3. Operation.....	6
4. Servicing.....	7
TROUBLE SHOOTING GUIDE.....	8
RECOMMENDED SEQUENCE OF DISASSEMBLY.....	10
RECOMMENDED SEQUENCE OF REASSEMBLY.....	17
TROLLEY SUSPENSIONS FOR AIR CABLE KING HOISTS.....	19
Powr-King Trolley.....	19
Sidewinder Trolley.....	21
Tractor Trolley.....	23
Equa-Drive Trolley.....	25
Geared Trolley.....	27
Plain Trolley.....	29
AIR FLOW DIAGRAM.....	31
SCHEMATIC FOR CLOSE HEADROOM HOISTS.....	32
SCHEMATIC FOR STANDARD HEADROOM HOISTS.....	33



CAUTION

DO NOT USE YALE HOISTS OR TROLLEYS FOR PASSENGER ELEVATOR APPLICATIONS.

The safety laws for passenger elevators specify construction details that are not incorporated in Yale Industrial Hoists. We recommend that passenger elevator operation equipment be used that meets all state and national safety codes. Yale Industrial Products, Inc. will not accept responsibility for applications of Yale Hoists on passenger elevators.

When Replacement Parts Are Needed, Order Only YALE[®] Factory Engineered Parts

INSTALLATION



GENERAL INSTALLATION INSTRUCTIONS

1. GENERAL INSTALLATION INSTRUCTIONS

Before shipment the hoist is rigidly tested and carefully adjusted for proper operation. However, the following points must be checked to insure correct installation and to avoid unnecessary damage to the hoist.

- (a) Check the limit switch by running the hook upward and lifting the paddle by hand. When the paddle is lifted from 1/2 to 2 inches the hoist will cut off.
- (b) Examine the hoisting rope for kinks or other damage. Make sure the rope lies smoothly in the grooves of the drum and sheaves.
- (c) LUBRICATION: Remove the oil filling plug on the gear housing to check the oil level. Oil should be up to the level of this plug. Under normal temperatures use Automatic Transmission Fluid Type "A". For higher or lower temperatures consult Eaton Corporation, Hoisting Equipment Division, Forrest City, Arkansas 72335.
- (d) MOTOR LUBRICATION: For ambient temperatures 30 degrees F. to 80 degrees F. use S.A.E. 30 Non Detergent Motor Oil. For ambient temperatures below 30 degrees F. use S.A.E. 20 or 20W Non Detergent Motor Oil. For ambient temperatures above 80 degrees F. use S.A.E. 40 Non Detergent Motor Oil.
- (e) MAINTAIN OIL LEVEL IN THE MOTOR CASE: At regular intervals, depending on the service to which the motor is subjected, check the oil in the motor case as follows:
 - (1) After the motor has been idle for several hours, open the oil cock at the bottom of the motor case and allow the accumulated water to drain out.
 - (2) Open the oil cock in the side of the motor case and unscrew the vent cap from the motor case.
 - (3) Add sufficient oil through the top opening to raise the oil level even with the open oil cock or sight glass in the side of the motor case.
- (f) The reservoir in the gear case lubricates all gears and bearings.
- (g) The motor, the load sheave and outer drum bearings are packed with grease at the factory and need not be replenished for years. This is a special grease that resists oxidation and leakage.



GENERAL INSTALLATION INSTRUCTIONS continued

- (h) It is advisable to occasionally put a few drops of machine oil on the brake linkage, particularly in an application where there is moisture.
- (i) Keep the hoisting rope coated with heavy oil or prepared cable lubricant to prevent rust and excessive wear.

2. MOTOR MAINTENANCE

- (a) **REVERSE VALVE REMOVAL:** Before attempting to withdraw the Reverse Valve from the Reverse Valve Bushing, unscrew the Throttle Valve Cap and withdraw the spring, Poppet Throttle Valve and ball.
- (b) **VALVE CHEST REMOVAL:** Remove the top two bolts from the Valve Chest and slip the Valve Chest out of the motor body.
- (c) **REMOVAL AND INSTALLATION OF BUSHINGS IN VALVE CHEST:** Use an arbor that will clear the Bushing Key that projects into each valve chest bore, and press on the bushing face that is flush with the valve chest face when pressing either the Rotary Valve Bushing or the Reverse Valve Bushing from the Valve Chest. Otherwise the bushing key will be sheared off.

Always press new Rotary Valve or Reverse Valve Bushing, grooved end first, into the motor case side of the Valve Chest, making certain that the groove along the side of the bushing is aligned with the Bushing Key. Press in the new bushing until its leading face is flush with the cover side of the Valve Chest.

Insert Throttle Valve Stem Reamer into the bottom bore of the Valve Chest from which the Poppet Throttle Valve was removed.

If the Rotary Valve is too tight in the new bushing, lap it to a good running fit; if too tight to lap, ream the bushing 1.625 inch.

- (d) **SHUTTLE VALVE REMOVAL:** Remove the Shuttle Valve Cap and withdraw the spring and washer from each end of the Shuttle Valve Chest. Remove the Stop Arm Shaft Pin and withdraw the assembled Stop Arm and Stop Arm Shaft. Withdraw the Shuttle Valve from the Shuttle Valve Bushings.
- (e) **REMOVAL AND INSTALLATION OF SHUTTLE VALVE BUSHINGS:** When pressing the Shuttle Valve Bushings from the Shuttle Valve Chest use a 1.375 inch diameter arbor with a 1.156 inch diameter pilot 1/2 inch long on one end. Insert the pilot into one bushing and press it out through the center cavity of the Valve Chest. Repeat this procedure to remove the other bushing.

When Replacement Parts Are Needed, Order Only YALE[®] Factory Engineered Parts

INSTALLATION



GENERAL INSTALLATION INSTRUCTIONS continued

Start a new bushing, level end first, into each end of the Shuttle Valve Chest and press it in until its trailing face reaches a depth of 2 1/16 inch.

Ream straight through both bushings to maintain bore concentricity between the two bushings.

- (f) PISTON RINGS AND CYLINDER INSTALLATION: Do not expand the Piston Rings more than is necessary to slide them over the Piston and into the groove.

Use a Piston Ring Compressor when installing the cylinder in the motor case.

When reassembling the motor, the parts of the crank pin and the Cylinder walls should be lubricated with the same type of oil recommended for use in the motor case.

3. REPAIR PARTS ORDERING INFORMATION

This instruction and installation manual contains all the data required to install and maintain your Cable King Air Hoist. To insure prompt service, place all parts orders with your local YALE[®] distributor.

Please give all information listed below in items (a), (b), (c) and (d). This will enable your distributor to fill your order promptly.

- (a) Give complete data from hoist nameplate.
- (b) Give part numbers, description and quantity of parts required.
- (c) Give correct shipping destination.
- (d) For ordering motor repair parts, give all data on the hoist and motor nameplates.

If it becomes necessary to return the complete hoist or certain parts to the factory, a letter requesting such a return is necessary. This letter should contain an explanation for requesting the return. A return authorization will be issued giving you clearance for returning the hoist or parts to the factory.

When Replacement Parts Are Needed, Order Only YALE[®] Factory Engineered Parts



**PERIODIC INSPECTION AND
PREVENTIVE MAINTENANCE**

1. LUBRICATION

- (a) **GEARING AND LOAD BRAKE:** The gearing and load brake is lubricated by a continuous oil bath. It is important that the level of the oil be maintained with the level of the filler plug. **DO NOT OVER-FILL.**
- (b) **BEARINGS:** All bearings used in the gear case are double shielded and are lubricated by the oil bath. All other bearings are sealed and lubricated for life. **NOISY OR WORN OUT BEARINGS SHOULD BE REPLACED.**
- (c) **HOISTING ROPE:** The hoist rope should be kept coated with a good grade cable lubricant to prevent rust and excessive wear. **NEVER ALLOW THE CABLE TO OPERATE DRY.**
- (d) **MOTOR BRAKE SHOE CAM:** To insure smooth operation of the motor brake, apply a light grease to the contact points of the cam and adjusting screws.

2. PREVENTIVE MAINTENANCE SCHEDULE

The preventive maintenance schedule is largely confined to a visual inspection of the unit. The periods between inspections will vary due to the wide range of duty cycles and operating conditions encountered with this type of equipment. The following inspection periods are based on an operation of approximately forty hours per week under normal environmental conditions.

DAILY INSPECTION

- (a) **MOTOR CHECK:** Open the oil cock at the bottom of the motor case and drain out accumulated water. Check the oil level as outlined previously.
- (b) **HOISTING ROPE:** All hoisting ropes should be examined each day for signs of wear or damage such as broken wires, abrasion, reduction in diameter, kinks, corrosion, etc. Less frequent inspection, depending upon your experience and use, should be made of the dead end and drum fittings of the rope. Wire rope should be replaced when the wear or corrosion has reached the point which indicates an unsafe condition.
- (c) **HOOKS AND SUSPENSION ADAPTERS:** Hooks which have become opened, bent, worn, or otherwise damaged should be replaced. **THE BOTTOM HOOK MUST SWIVEL FREELY.** Make sure all suspension pins and nuts are tight.

When Replacement Parts Are Needed, Order Only YALE[®] Factory Engineered Parts

PREVENTIVE MAINTENANCE



PREVENTIVE MAINTENANCE SCHEDULE continued

NOTE: A bent or open hook indicates improper or excessive loading which may result in other damaged parts.

- (d) **SHEAVES AND DRUM:** All rope sheaves and drum should be inspected regularly. When the groove of a sheave or rope drum becomes worn excessively the sheave should be replaced. Worn grooves on the drum or sheave can greatly reduce the useful life of the hoisting rope.
- (e) **LIMIT SWITCHES:** Limit switches should be tested without a load on the hook at the beginning of each work shift. Extreme care should be exercised and, where possible, the limit should be actuated manually for testing. When it is impossible to test the limit manually the block should be "inched" into the limit or run in at slow speed.

With the bottom hook five feet or more below the bottom of the hoist check the limit switch by running the hook upward and lifting the paddle by hand. When the paddle is lifted from 1/2 to 2 inches the hoist should cut off.

If the limit switch does not perform as described above, the hoist should be removed from service until it is repaired and operating correctly.

MONTHLY INSPECTION

- (f) **MOTOR BRAKE SHOES:** At least once a month or twice a month, depending on the hoist duty, remove the end cover and check the motor brake shoes for excessive or uneven wear. If one or both of the shoes are worn to the rivets, both shoes should be replaced. If the brake drum is worn or scored it should be replaced. Check the motor brake cylinder, making sure the tube connection is tight.
- (g) **HOSE AND TUBING:** Check the air lines to be sure all connections are tight and that all fittings are securely fastened. Check the hose and tubing for kinking, cuts, cracks, brittleness or swelling. Replace hose and/or tubing when necessary.
- (h) **SUSPENSION POINTS AND COVERS:** Inspect gear case, motor and suspension frame to see that they are securely fastened and that no screws or lockwashers are missing. Tighten all screws and replace all missing or damaged hardware. Inspect all load bearing parts for cracks, particularly if the hoist has been dropped or bumped against a wall, beam or other solid obstruction. A crack in these parts indicates mistreatment or severe overloading, either one of which is highly dangerous. Replace all damaged parts.

When Replacement Parts Are Needed, Order Only YALE[®] Factory Engineered Parts



OPERATING AND MAINTENANCE INSTRUCTIONS FOR TROLLEY MOTOR

1. CONSTRUCTION

Your air motor is a precision built rotary type motor. The top clearance (between rotor and bore) is .0015". The total end clearance (between the sides of the rotor and the end plates) is .0035". The vanes take up their own wear and will last 5,000-15,000 hours depending upon speed, method of oiling, operating pressure, and the precautions taken in maintaining the motor. The type of shaft seal used does not lend itself to operating pressures above 100 p. s. i. Allowing excess moisture or foreign particles from the air line to enter the motor will nullify the guarantee.

2. INSTALLATION

Install a moisture trap and filter in the air line ahead of motor. For efficiency of output and control of speed use air lines the same size as or the next pipe size larger than the intake port of the motor. If operating intermittently without automatic air line oiler place motor in accessible position for easy lubrication. When coupling or connecting the motor to a driven member avoid any end or side thrust on the shaft and especially do not hammer on shaft.

3. OPERATION

The stalled or starting torque is less than the running torque and will vary depending on the position at which the vanes stop in relation to the air intake port. The use of gear or pulley reductions will benefit starting of the driven member. Operate motor well below available line pressure so that full line pressure can be called upon for over-loads on motor. The speed can be regulated by using a pressure regulator or a simple shut-off valve. The torque can be varied with the help of a pressure regulating valve (diaphragm type).

For moderate speeds (under 2,000 r. p. m.) or intermittent operation one squirt of oil in bearing oiler per day will suffice. If the duty is continuous or speed is high use an automatic air line oiler set to feed one drop per minute. The bearings will receive oil from the rotor chamber during automatic oiling. Use SAE #10 oil. Lubrication is necessary for the bearings, shaft seals, and rust prevention. Excessive moisture in the air line can cause rust formation in motor and might also cause ice to form on muffler due to expansion of air thru the motor. The moisture problem can be corrected by installing a moisture separator in the line and also by installing an aftercooler between the compressor and air receiver.

When Replacement Parts Are Needed, Order Only YALE[®] Factory Engineered Parts



OPERATING and MAINTENANCE INSTRUCTIONS continued

4. SERVICING

If the motor is sluggish or inefficient try flushing with kerosene in well ventilated area. Disconnect the air line and muffler and add several teaspoonsful of kerosene. Rotate the shaft by hand in both directions for a few minutes, again connect the air line and apply pressure slowly until there is no trace of kerosene in exhaust air. (Keep face away from exhaust air). Check the muffler felts for grease, dirt, etc. If dirty wash them in solvent. Replace the felts and connect the muffler. Relubricate the muffler. Relubricate the motor with a squirt of oil in the chamber and bearing oilers.

If the vanes need replacing, or foreign particles are present in motor chamber, an experienced mechanic may remove the end plate opposite the drive shaft end. Don't pry with a screw driver as it will dent the surface of the plate and body causing leaks. A pul-
ler tool should be used which will remove the end plate while maintaining the position of the shaft. New vanes should have the edge with the corners cut on angle or the notched edge (if reversible) towards the shaft in the slot. New gaskets should be the proper thickness onion skin otherwise motor will operate inefficiently and waste air. The end plate should be replaced carefully using an arbor press with a pusher acting on both races of the bearing while supporting the opposite (drive) end of the shaft rigidly. This will eliminate brinelling of the bearings and misalignment of rotor.

It is usually quickest and cheapest to send the motor to the factory for repair. When corresponding indicate the serial number complete with prefix.

When Replacement Parts Are Needed, Order Only YALE[®] Factory Engineered Parts



HOOK DOES NOT STOP PROMPTLY continued

(d) Motor Brake Slipping

Replace brake shoes. Adjust brake per paragraph back of brake shoe page.



RECOMMENDED SEQUENCE OF DISASSEMBLY

Before doing any maintenance work on the hoist read the instructions thoroughly. By following these instructions you will save time and trouble.

TO COMPLETELY DISASSEMBLE THE HOIST: Follow all of the disassembly procedures in the order they are listed.

TO DISASSEMBLE ANY ONE SPECIFIC SUB-ASSEMBLY OF THE HOIST (such as the motor, geared limit switch, etc.): Follow the instructions for that specific sub-assembly.

GROUP 1: PRELIMINARY DISASSEMBLY PROCEDURES

- (a) Lower the bottom block by running the hoist in the down direction until the cable is completely off the drum.
- (b) On standard headroom units remove the cotter pins from the rope anchor pin and slide the pin out of the mounting lugs on the suspension frame. On low headroom units slip the rope sockets out of holes in the rope drum and remove the equalizer sheave.

CAUTION

BEFORE CONTINUING FURTHER WITH THE DISASSEMBLY PROCEDURE, DISCONNECT THE AIR SUPPLY LINE.

- (c) After the air supply has been cut, if the hoist is to be completely disassembled, remove the drain plug on the underside of the gear case and drain the oil into a bucket. Then replace the drain plug.

NOTE: Do not remove the pawl stop plug from the hoist gear case cover.

- (d) The hoist should now be removed from the working area and, if possible, placed on a maintenance bench for further disassembly.

NOTE: Never disassemble the hoist in dirty surroundings or allow dirt, grit or any other foreign material to get into the working parts of the hoist or into the working area of those parts.

GROUP 2: TO REMOVE THE HOIST ROPE, BOTTOM BLOCK OR BOTTOM HOOK

- (a) Standard Headroom Hoist
 - (1) Operate hoist in down direction until rope socket(s) falls or can be pulled from the rope drum.
 - (2) Remove air supply from the hoist.
 - (3) Disassemble bottom block and remove hoist rope.

When Replacement Parts Are Needed, Order Only YALE[®] Factory Engineered Parts



TO REMOVE THE HOIST ROPE, BOTTOM BLOCK OR BOTTOM HOOK continued

(4) Remove pin holding the cable in the hoist frame.

(b) Low Headroom Hoist

(1) Follow procedures in GROUP 2 (a), 1, 2 and 3.

(2) Remove pin holding equalizer sheave yoke in hoist frame.

(3) Remove axle holding the sheave in the yoke and remove cable.

GROUP 3: TO REMOVE THE MOTOR BRAKE CYLINDER

(a) "B" Chassis Hoist

(1) Remove air supply from hoist.

(2) Remove louvered end cover from hoist gear case cover.

(3) Disconnect tubing from cylinder.

(4) Remove two bolts and nuts holding cylinder to the mounting bracket.

(b) "C And D" Chassis Hoist

(1) Follow procedures in GROUP 3 (a), 1, 2 and 3.

(2) Remove two bolts and lockwashers holding cylinder.

(3) Remove tubing from cylinder.

(c) "E" Chassis Hoist

(1) Follow procedures in GROUP 3 (a), 1, 2 and 3.

(2) Remove two bolts, lockwashers and cover plate over motor brake cylinder assembly.

(3) Disconnect tubing from cylinder.

(4) Remove two bolts and lockwashers holding solenoid mounting bracket in the gear case.

(5) Remove cylinder from hoist.

GROUP 4: TO REMOVE THE MOTOR BRAKE SHOES

(a) "B" Chassis Hoist

When Replacement Parts Are Needed, Order Only YALE[®] Factory Engineered Parts



TO REMOVE THE MOTOR BRAKE SHOES continued

- (1) Follow procedures in GROUP 3 (a), 1, 2, 4 and 5 to get the cylinder out of the way.
 - (2) Remove cotter pin from brake shoe pivot stud.
 - (3) Pry brake shoes off of the stud.
- (b) "C, D or E" Chassis Hoist
- (1) Follow procedures in GROUP 3 (a), 1 and 2.
 - (2) Follow procedures in GROUP 4 (a), 2 and 3.

GROUP 5: TO REMOVE THE MOTOR BRAKE DRUM

- (a) "B" Chassis Hoist
- (1) Follow procedures in GROUP 3 (a), 1, 2, 4 and 5 to get the cylinder out of the way.
 - (2) Remove the cotter pin and castellated nut from the end of the driving pinion.
 - (3) Loosen the jam nuts on the motor brake adjusting screws. Open the motor brake by running the adjusting screws up against the brake cam.
 - (4) Using two hook type pry bars, pry the brake drum off the driving pinion.
- (b) "C, D or E" Chassis Hoist
- (1) Follow procedures in GROUP 3 (a), 1 and 2 and GROUP 5 (a), 2, 3 and 4.

GROUP 6: TO REMOVE THE DRIVING PINION, DRIVING PINION BEARING OR DRIVING PINION COUPLING

- (a) "B" Chassis Hoist
- (1) Follow procedures in GROUP 3 (a), 1, 2, 4 and 5 to get the cylinder out of the way.
 - (2) Remove three bolts and lockwashers from driving pinion retainer plate.
 - (3) Remove cotter pin from the castellated nut. Loosen, do not remove, the castellated nut one or two turns.

DISASSEMBLY



TO REMOVE THE DRIVING PINION, DRIVING PINION BEARING OR DRIVING PINION COUPLING continued

- (4) Open brake shoes by loosening the jam nuts on the brake shoe adjusting screws and running the screws up against the brake cam.
 - (5) Using two hook type pry bars, pry between the motor brake drum and gear case cover. Pull entire pinion assembly out of the hoist. This may require some pressure in order to disengage the driving pinion coupling from the motor shaft.
 - (6) Grip driving pinion tightly in a vise.
 - (7) Use a bearing puller to remove motor brake drum.
 - (8) Remove spacer ring between brake drum and pinion bearing.
 - (9) Using a bearing puller or an arbor press, remove bearing.
 - (10) Using an arbor press or bearing puller, remove coupling.
- (b) "C, D or E" Chassis Hoist
- (1) Follow procedures in GROUP 3 (a), 1 and 2 and GROUP 6 (a), 2 through 10.

GROUP 7: TO REMOVE THE HOIST MOTOR, MOTOR ADAPTER

- (a) If possible, run hoist in down direction and clear all rope from the hoist drum.
- (b) Disconnect air supply from the hoist.
- (c) Disconnect tubing.
- (d) Remove four bolts and lockwashers holding motor to suspension frame.
- (e) Work motor loose enough to allow insertion of a pry bar between motor adapter and suspension frame.
- (f) Remove motor by prying between suspension frame and motor adapter. This will require some pressure as the weight of the rope drum and possibly bottom block and hoist rope will be resting on the drum shaft bearing in the motor adapter.

GROUP 8: TO REMOVE THE HOIST ROPE DRUM

- (a) Follow procedures in GROUP 7 to remove motor.
- (b) Remove snap ring from the drum shaft.

When Replacement Parts Are Needed, Order Only YALE[®] Factory Engineered Parts



TO REMOVE THE HOIST ROPE DRUM continued

- (c) Pry rope drum off drum shaft.

GROUP 9: TO REMOVE THE GEAR CASE COVER

NOTE: The gear case cover of the D and E Chassis Hoist are very heavy. It is advisable to either suspend the cover or build up shoring underneath it before you start to work.

- (a) If possible, run hoist in down direction and clear all cable from the hoist drum.
- (b) Disconnect the air supply from the hoist.
- (c) Disconnect tubing.
- (d) Remove oil drain plug from the bottom of the gear case cover and drain the oil into bucket.
- (e) Follow procedures in GROUP 6 to remove driving pinion.
- (f) Remove nuts, bolts and lockwashers from the gear case and gear case cover flange.
- (g) Work cover loose enough to allow insertion of two pry bars or large screwdrivers between the cover and gear case.
- (h) Pry cover and case apart. Be careful when removing the cover. In the C, D and E Chassis there is a combination gear and pinion that may drop out of the cover.

GROUP 10: TO REMOVE THE DRUM SHAFT AND DRUM GEAR

- (a) Follow procedures in GROUPS 7, 8 and 9.
- (b) On C and D Chassis hoist, remove spacer ring from drum shaft.
- (c) Remove drum shaft from hoist by pulling on drum gear.

GROUP 11: TO REMOVE THE LIMIT SWITCH

- (a) Traveling Nut Or Geared Limit Switch
 - (1) Disconnect the air supply from hoist.
 - (2) Remove three bolts and lockwashers holding the limit switch to the gear case cover.
- (b) Low Headroom Paddle Operated Switch

DISASSEMBLY



TO REMOVE THE LIMIT SWITCH continued

- (1) Disconnect the air supply.
 - (2) Disconnect the tubing to the limit switch.
 - (3) Remove cotter pin and washers from the end of the limit switch cam and shaft assembly.
 - (4) Remove the nut and bolt holding the limit paddle on the shaft.
 - (5) Remove the limit paddle by sliding it off of the end of the cam and shaft assembly.
 - (6) Remove the cam and shaft assembly.
 - (7) Remove the fittings from the limit switch.
 - (8) Remove two screws and lockwashers holding the air valve to box.
- (c) Paddle Operated Switch on Standard Headroom Hoist
- (1) Disconnect the air supply from the hoist.
 - (2) Remove link between paddle and operating lever.
 - (3) Remove cotter pins from paddle pivot shaft.
 - (4) Remove pivot shaft, spacer and paddle.

GROUP 12: TO REMOVE THE GEAR CASE

NOTE: This applies only to C, D and E Chassis hoist. The "B" Chassis gear case is an integral part of the suspension frame and cannot be removed.

- (a) Follow procedures in GROUPS 6, 7, 8, 9 and 10.
- (b) Remove nuts, bolts and lockwashers holding gear case to suspension frame. Remove gear case.

NOTE: The D and E Chassis gear cases are very heavy. If possible it is best to support this part prior to removal.

GROUP 13: TO REMOVE THE LOAD BRAKE ASSEMBLY AND LOAD BRAKE PAWL

- (a) Follow procedures in GROUPS 6 and 9.
- (b) Cover the ratchet pawl with a rag. This will prevent loosing the retainers when they pop out of the pawl.

When Replacement Parts Are Needed, Order Only YALE[®] Factory Engineered Parts



TO REMOVE THE LOAD BRAKE ASSEMBLY AND LOAD BRAKE PAWL continued

- (c) Remove pawl stop and/or spring assembly.
- (d) Rotate the load brake assembly until the pawl clears the load brake and the retainers pop out of the pawl.
- (e) Recover the retainers and spring.
- (f) Remove pawl pin and pawl. The D Chassis has a cotter pin through the pawl and pawl pin. To remove the pawl or pawl pin it will be necessary to remove the cotter pin.
- (g) Using the hook type pry bars, pry the load brake assembly out of the gear case cover.

REASSEMBLY



RECOMMENDED SEQUENCE OF REASSEMBLY

Reassembly of any Cable King hoist is basically the reverse of the disassembly. However, the following reassembly procedures should be followed.

1. MOTOR BRAKE

Prior to putting the shoes back on the pivot stud there should be a light coating of grease applied to the stud, the face of the adjusting screws and the face of the cam.

Prior to installing the brake drum on the driving pinion lubricate the spline on the pinion and the spline in the brake drum. This will prevent undue wear of these splines.

Refer to parts page for adjusting instructions.

2. ROPE DRUM AND DRUM SHAFT

Be sure there is no prime paint or any other material in the drum spline area that will interfere with the installation of the rope drum.

Drum should be a light press fit on the shaft. If not, do not drive it on. Remove the drum and find out what is causing a tight fit.

Lubricate the drum spline and the splines in the shaft to prevent wear.

Prior to installation of the drum shaft in the hoist, the drum shaft bearings should be lubricated with Gulf XXX Number 1 grease. The grease should be worked into the bearing with a layer left on top. There should also be a thin layer left on the shaft in the area where the seals ride to provide lubrication for the lip of the seal.

In some cases the drum shaft bearings on the "B" Chassis hoist have a tendency to come apart when the drum shaft or motor is removed. By this, we mean that some of the rollers will come out of the cage. In order to reduce time in reassembly of the hoist, the easiest method is to load the bearing with grease and replace the rollers one at a time. Care in installing the motor and drum shaft is necessary to prevent upsetting the rollers during this phase of reassembly.

Install the drum shaft seal in an upside down position in the hoist gear case. This sets the lip of the seal facing toward the inside of the gear case. The seal can be damaged beyond use if care is not exercised during the installation of the shaft. This installation can be made by using a piece of .0015 or .002 inch thick shim stock wrapped around the splines.

When Replacement Parts Are Needed, Order Only YALE[®] Factory Engineered Parts



RECOMMENDED SEQUENCE OF REASSEMBLY continued

After the drum shaft has been installed, a check of the run out of the face of the drum gear should be made. This will prevent damage to the gear train due to improper tooth loading. Maximum run out figures are shown below:

"B" Chassis	.009	T.I.R.	At	7.5	Inch Diameter
"C" Chassis	.008	T.I.R.	At	6.0	Inch Diameter
"D" Chassis	.009	T.I.R.	At	8.0	Inch Diameter
"E" Chassis	.012	T.I.R.	At	10.0	Inch Diameter

This check can be made by mounting a dial indicator with a magnetic base on the gear case. In order to assure an accurate reading it will be necessary to take up all of the slack in the drum and shaft assembly by pushing against the center of the drum gear.

3. MOTOR AND/OR ADAPTER

Be sure there is a bearing and seal in any new motor or motor adapter being installed in a hoist.

Lubricate the drum shaft bearing with Gulf XXX Number 1 grease. Lubricate the motor spline with a light coating of grease.

4. LIMIT SWITCH

Lubricate cam and shaft assembly with a light grease and light machine oil on all pivot points.

Refer to parts page for adjusting instructions.

5. LOAD BRAKE

Refer to parts page for repair and adjustment of load brake.

6. GEAR CASE COVER

Apply a light coating of Number 1 or 2 Grade Permatex to the face of the retainer plate and mating surface on the gear case cover. Apply a light coating of grease to the pinion spline and coupling spline.

SUSPENSION OF POWR-KING TROLLEY

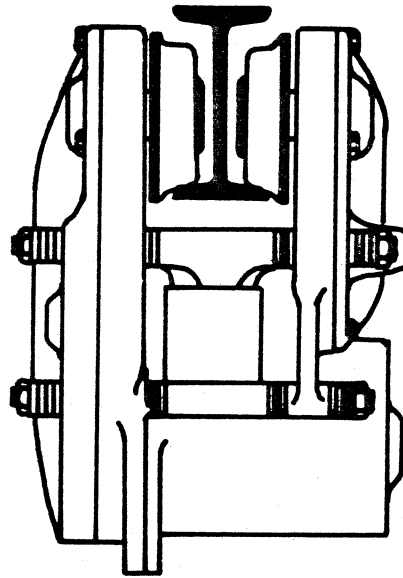
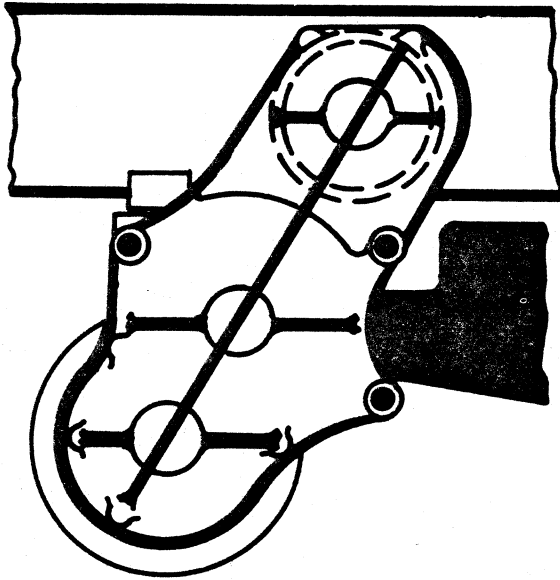

1. Inspect the trolley for any damage that may have occurred during shipment and remove the wooden block from between the wheels.

2. Since the trolley has been rigidly inspected and carefully adjusted for proper operation and fit to the I-beam specified on your order, very little adjustment, if any, need be made at installation. It is important that the trolley be assembled properly on the beam. If adjustment is necessary refer to the spacer washer chart on opposite page.

3. If the I-beam is open on one end, it is not necessary to disassemble the trolley for installation. Simply raise the unit up to the beam and slide the trolley onto the flange. If the beam is not open follow the steps as listed below.

4. Remove the nuts, lockwashers and spacer washers from the double end studs on the side opposite the motor mounting. Remove the complete side case assembly and raise the unit to the beam.

5. Reassemble the trolley on the beam being careful to seat the spline shaft properly in the gear inside of the side case. Tighten all the nuts securely. If the trolley is adjusted properly there should be approximately 1/8" between the flange of each wheel and the edge of the I-beam.

6. Check all hardware to make sure they are tight and that the hoist is securely fastened to the trolley. Then complete steps 3 thru 13 of the hoist installation procedures.

7. After all of the hoist installation and inspection procedures have been completed the trolley should be tested beginning with no load and working up to full load.

8. Run the trolley back and forth noticing that it tracks properly and runs freely without any sign of binding.

9. If travel limit switches are used notice the travel distance of the trolley after the push button is released. Set the switches to stop the trolley a safe distance from any obstruction.

When Replacement Parts Are Needed, Order Only YALE[®] Factory Engineered Parts

SIDEWINDER



SUSPENSION OF SIDEWINDER TROLLEY

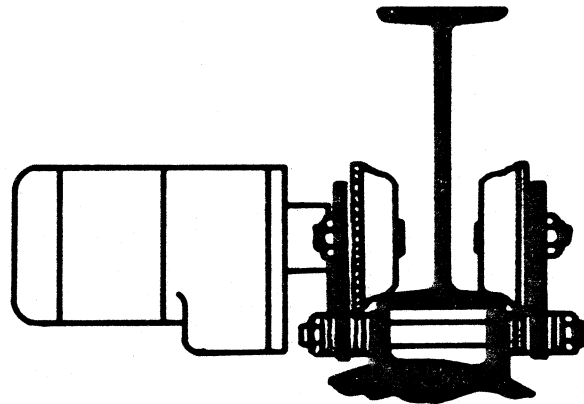
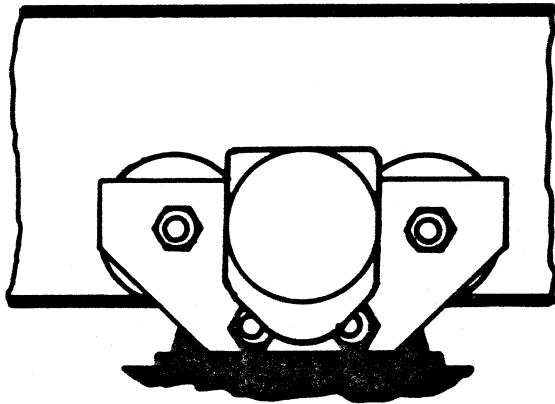

1. Inspect the trolley for any damage that may have occurred during shipment and remove the wooden blocks from between the wheels.

2. Since the trolley has been rigidly inspected and carefully adjusted for proper operation and fit to the I-beam specified on your order, very little adjustment, if any, need be made at installation. It is important that the trolley be assembled properly on the beam. If adjustment is necessary refer to the spacer washer chart on opposite page.

3. If the I-beam is open on one end, it is not necessary to disassemble the trolley for installation. Simply raise the unit up to the beam and slide the trolley onto the flange. If the beam is not open, follow the steps as listed below.

4. Remove the nuts, lockwashers and spacer washers from the double end studs on the side opposite the motor.

5. Remove the sideplate and raise the unit up to the I-beam.

6. Set the wheels of the motor side on the I-beam and reassemble the trolley. Tighten the nuts carefully. If the trolley is adjusted properly there will be approximately 1/8" between the flange of each wheel and the edge of the I-beam flange as shown in the illustration.

7. Check all the nuts and bolts to make sure they are tight and that the hoist is securely fastened to the trolley then complete steps 3 thru 13 of the hoist installation procedures.

8. After all of the hoist installation and inspection procedures have been completed the trolley should be tested beginning with no load and working up to full load.

9. Run the trolley forward and reverse noticing that it tracks properly on the beam and that it runs freely without any sign of binding.

10. If travel limit switches are used notice the travel distance of the trolley after the push button is released and set the switches to stop the trolley a safe distance from any obstruction.

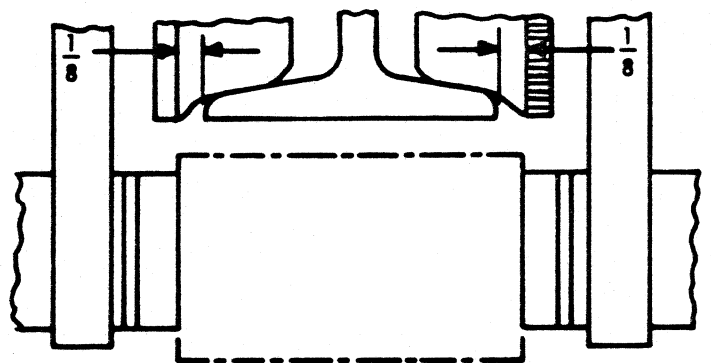

When Replacement Parts Are Needed, Order Only YALE[®] Factory Engineered Parts



SUSPENSION OF RAIL KING TRACTOR TROLLEY

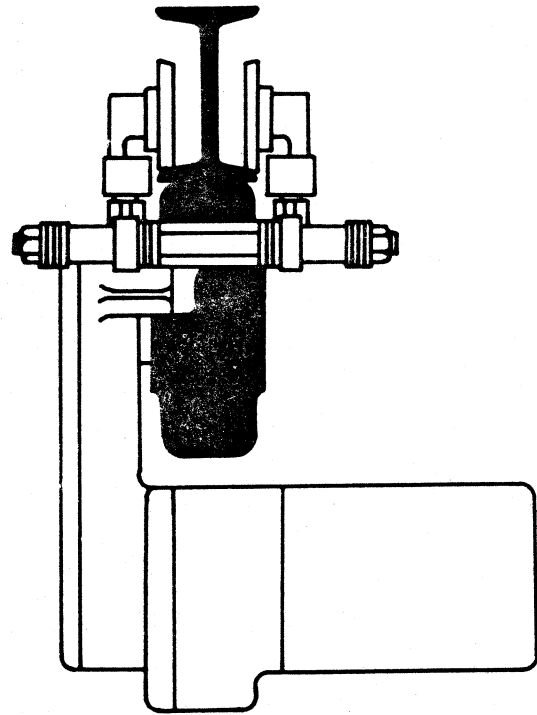
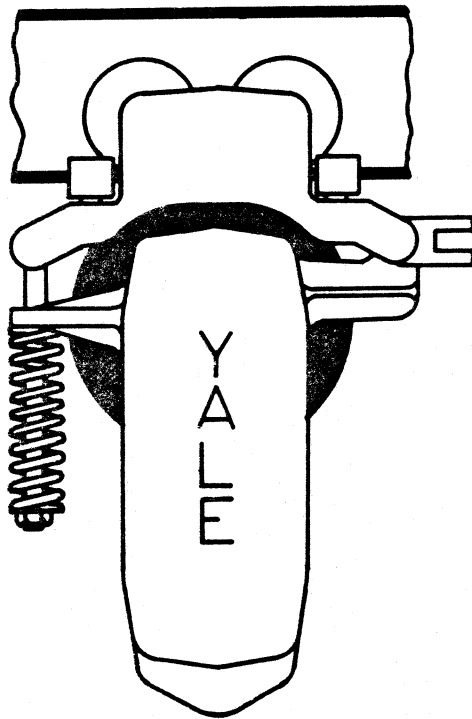

1. Inspect the trolley for any damage that may have occurred during shipment and remove the wooden block from between the wheels of the plain trolley.

2. Since the trolley has been rigidly inspected and carefully adjusted for proper operation and fit to the I-beam as specified on your order, very little adjustment, if any, is required at installation. It is important that the trolley be assembled properly on the beam. If adjustment is necessary refer to the spacer washer chart on opposite page for the tractor trolley and page 19 for the plain trolley.

3. If the I-beam is open on one end it is not necessary to disassemble the trolley for installation. Simply raise the unit up to the beam and slide the trolley onto the flange, then slide the tractor unit on the flange and connect the towbar. If the beam is not open follow the steps listed below.

4. Remove the nuts, the lockwashers and the spacer washers from the double end studs of the plain trolley. Remove the sideplate and raise the unit up to the beam.

5. Place the wheels of the trolley on the flange and reassemble the trolley. Tighten all nuts securely.

6. Remove the nuts, lockwashers and spacer washers from the tractor double end studs and remove the sideplate. Raise the tractor to the beam and reassemble the trolley. Tighten all nuts securely.

7. Connect the towbar and check all nuts for tightness. Then complete steps 3 thru 12 of the hoist installation procedures.

8. After the hoist installation and inspection procedures have been completed the trolley should be tested starting with no load and working up to full load. Run the trolley forward and reverse noticing that it tracks properly on the beam and that it runs freely without binding.

9. If travel limit switches are used notice the travel distance of the trolley after the push button has been released and set the switches to stop the trolley a safe distance from any obstruction.

When Replacement Parts Are Needed, Order Only YALE[®] Factory Engineered Parts



TABULATION OF ADJUSTING WASHERS
RAIL KING TRACTOR TROLLEYS

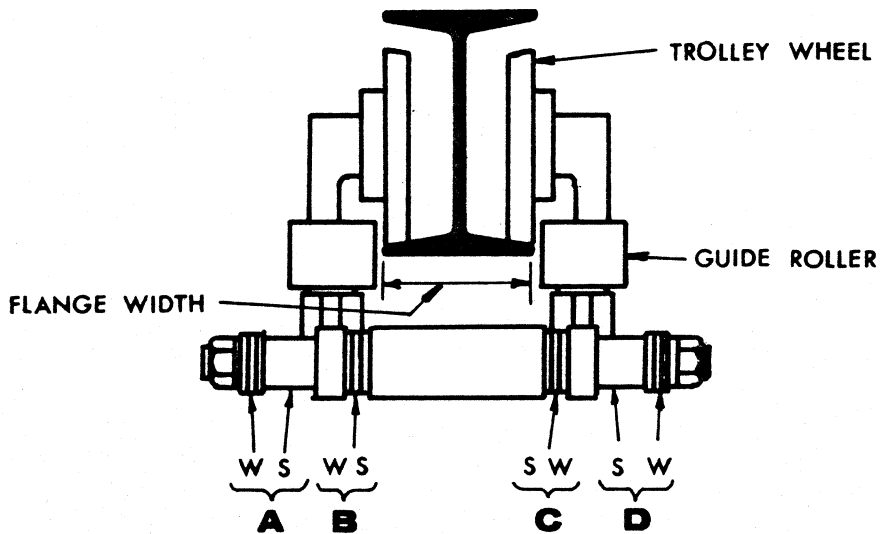

FLANGE WIDTH	NBR WSHR	NBR SPAC	A		B		C		D	
			W	S	W	S	S	W	S	W
2.00''	12	2	6	1	0	0	0	0	1	6
3.00''	12	2	3	1	3	0	0	3	1	3
3.25''	12	2	2	1	4	0	0	4	1	2
3.33''	12	2	2	1	4	0	0	4	1	2
3.66''	12	2	1	1	5	0	0	5	1	1
4.00''	12	2	6	0	0	1	1	0	0	6
4.33''	12	2	5	0	1	1	1	1	0	5
4.66''	12	2	4	0	2	1	1	2	0	4
5.00''	12	2	3	0	3	1	1	3	0	3
5.25''	12	2	2	0	4	1	1	4	0	2
6.00''	12	2	0	0	6	1	1	6	0	0

When Replacement Parts Are Needed, Order Only YALE[®] Factory Engineered Parts

SUSPENSION OF EQUA-DRIVE TROLLEY

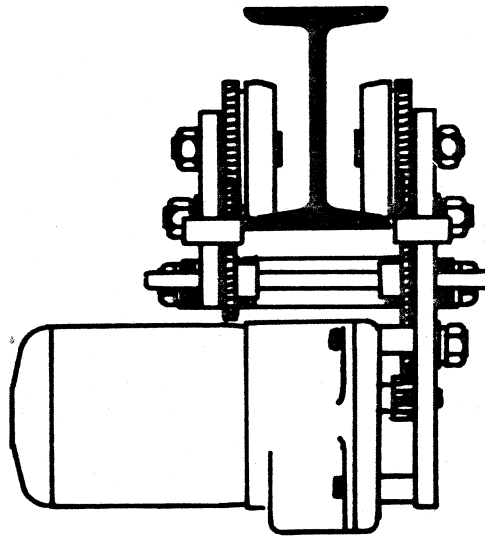
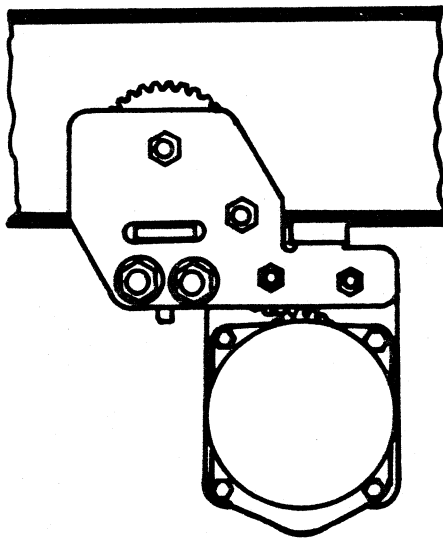

1. Inspect the trolley for any damage that may have occurred during shipment and remove the wooden blocks from between the wheels.
2. Since the trolley has been rigidly inspected and carefully adjusted for proper operation and fit to the I-beam specified on your order, very little adjustment, if any, need be made at installation. It is important that the trolley be assembled properly on the beam. If adjustment is necessary, refer to the spacer washer chart on the opposite page.
3. If the I-beam is open on one end, it is not necessary to disassemble the trolley for installation. Simply raise the unit up to the beam and slide the trolley onto the flange. If the beam is not open, follow the steps as listed below.
4. Remove the nuts, lockwashers and spacer washers from the suspension studs on the side opposite the motor sideplate.
5. Loosen the set screw from the drive gear (opposite the motor side) and then remove the square key. Slide the guide gear toward the motor side.
6. Remove the sideplates (opposite the motor side) and raise the unit up to the beam.

7. Set the wheels of the motor side on the I-beam and replace the side plate (opposite motor side), spacer washers, lockwashers and nuts. Tighten the nuts securely. If the trolley is adjusted properly there should be approximately $3/32''$ between the flange of the and the guide rollers on the sideplate.
8. Slide the drive gear back to its original position against the sideplate and replace the square key and set screw. Tighten the set screw securely.
9. Check all the nuts and bolts to make sure they are tight and that the hoist is securely fastened to the trolley. Then complete steps 3 thru 13 of the hoist installation procedures.
10. After the hoist installation and inspection procedures have been completed the trolley should be tested starting with no load and working up to a full load.
11. Run the trolley back and forth noticing that it tracks properly on the beam and that it runs freely without any sign of binding.
12. If travel limit switches are used, notice the travel distance of the trolley after the push button has been released and set the switches to stop the trolley at a safe distance from any obstruction.

When Replacement Parts Are Needed, Order Only YALE[®] Factory Engineered Parts

GEARED



SUSPENSION OF GEARED TROLLEY

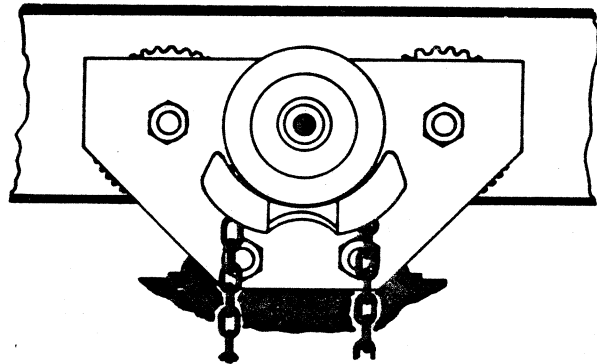
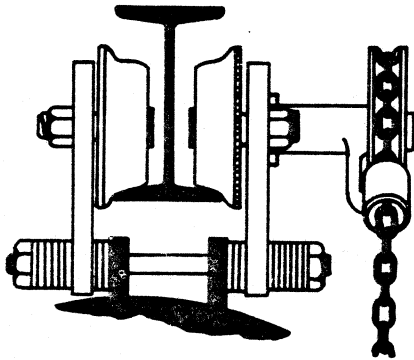

1. Inspect the trolley for any damage that may have occurred during shipment and remove the wooden block from between the wheels.

2. Since the trolley has been rigidly inspected and carefully adjusted for proper operation and fit to the I-beam specified on your order, very little adjustment, if any, need be made at installation. It is important that the trolley be assembled properly on the beam. If adjustment is necessary refer to the spacer washer chart on opposite page.

3. If the I-beam is open on one end, it is not necessary to disassemble the trolley for installation. Simply raise the unit up to the beam and slide the trolley onto the flange. If the beam is not open follow the steps as listed below.

4. Remove the nuts, lockwashers and spacer washers from the double end studs on the side opposite the hand chain wheel. Now remove the sideplate and raise the unit up to the beam.

5. Reassemble the trolley on the beam and tighten all nuts securely. If the trolley is adjusted properly there will be approximately $\frac{1}{8}$ " between the flange of each wheel and the edge of the I-beam flange as shown in the illustration.

6. Check all hardware to make sure they are tight and that the hoist is securely fastened to the trolley. Then complete steps 3 thru 12 of the hoist installation procedures.

7. After all of the hoist installation and inspection have been completed the trolley should be tested starting with no load and working up to full load.

8. Pull the hand chain causing the trolley to go back and forth noticing that it tracks properly and that it runs freely without any sign of binding.

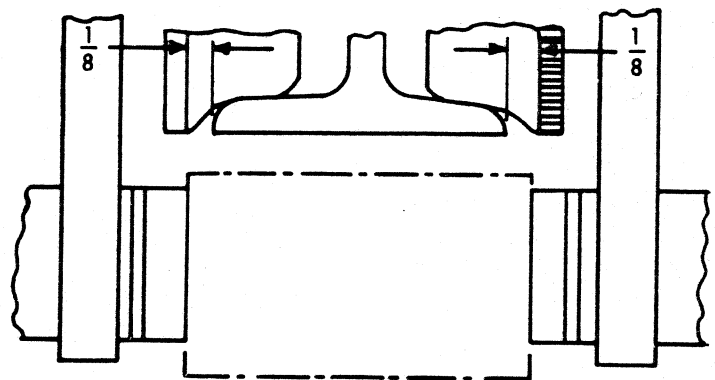

When Replacement Parts Are Needed, Order Only YALE[®] Factory Engineered Parts



GEARED

TABULATION OF ADJUSTING WASHERS
GEARED TROLLEYS

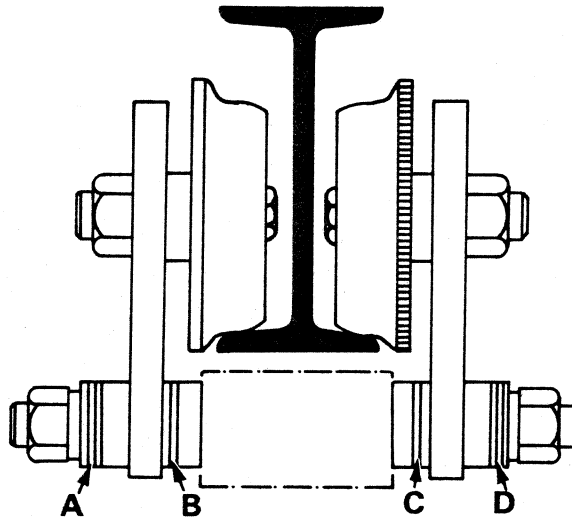

HOIST I-BEAM SIZES STANDARD	101G 106G 111G 116G 121G 126G 131G 136G 141G 146G 151G 156G 201G 226G 251G 276G																401G 403G 421G 423G																101CG 106CG 111CG 116CG 121CG 126CG 131CG 136CG 141CG 201CG 226CG 251CG																401CG 403CG 426CG																206G 211G 216G 221G 231G 236G 241G 246G 256G 261G 266G 271G 281G 296G 291G 286G 405G 406G 413G 425G 429G 433G 441G 445G 449G 457G 461G 465G 601G 626G															
	NBR		NBR		A		B		C		D		NBR		NBR		A		B		C		D		NBR		NBR		A		B		C		D		NBR		NBR		A		B		C		D																																	
	WSHR	SPCR	W	S	W	S	W	S	W	S	W	S	WSHR	SPCR	W	S	W	S	WSHR	SPCR	W	S	W	S	WSHR	SPCR	W	S	W	S	WSHR	SPCR	W	S	W	S	WSHR	SPCR	W	S	W	S	WSHR	SPCR	W	S	W	S																																
5'- 10.0 LB. - 3.00" FLANGE	20	0	7	0	3	0	0	2	0	0	0	19	0	0	0	0	0	10	2	3	1	2	0	0	10	2	0	1	5	0	0	4	1	1	12	2	6	1	0	0	0	0	1	6																																				
6'- 12.5 LB. - 3.33" FLANGE	20	0	6	0	4	0	0	3	0	7	19	0	0	0	0	0	3	0	10	2	2	1	3	0	0	10	2	0	1	5	0	0	5	1	1	1	0	0	5	12	2	4	1	2	0	0	2	1	4																															
8'- 18.4 LB. - 4.00" FLANGE	20	0	4	0	6	0	0	5	0	5	19	0	0	0	0	0	5	0	10	2	0	1	5	0	0	10	2	0	1	5	0	0	5	1	1	0	0	5	12	2	4	1	2	0	0	2	1	4																																
9'- 21.8 LB. - 4.33" FLANGE	20	0	3	0	7	0	0	6	0	4	19	0	0	0	0	0	6	0	10	2	0	0	1	1	0	0	10	2	0	0	1	1	0	4	1	1	0	4	12	2	2	1	4	0	0	3	1	3																																
10'- 25.4 LB. - 4.66" FLANGE	20	0	2	0	8	0	0	7	0	3	19	0	0	0	0	0	7	0	10	2	0	0	1	1	1	0	4	10	2	2	0	3	1	1	2	0	3	12	2	1	1	5	0	0	4	1	2																																	
12'- 31.8 LB. - 5.00" FLANGE	20	0	1	0	9	0	0	8	0	2	19	0	0	0	0	0	8	0	10	2	0	0	2	1	1	2	0	10	2	1	0	4	1	1	3	0	2	12	2	0	1	8	0	0	5	1	1																																	
15'- 42.9 LB. - 5.50" FLANGE	20	0	0	0	10	0	0	10	0	0	19	0	0	0	0	0	9	0	10	2	0	1	0	4	1	1	3	0	2	0	0	5	1	1	5	0	0	12	2	5	0	1	1	1	0	5																																		
18'- 54.7 LB. - 6.00" FLANGE	29	0	2	0	12	0	0	12	0	3	28	0	0	0	0	0	12	0	20	2	5	0	5	1	1	5	0	20	2	4	0	6	1	1	7	0	3	12	2	2	0	3	1	1	2	0	4																																	
20'- 65.4 LB. - 6.25" FLANGE	29	0	2	0	13	0	0	12	0	2	28	0	0	0	0	0	12	0	20	2	4	0	6	1	1	6	0	20	2	3	0	7	1	1	8	0	2	12	2	2	0	4	1	1	3	0	3																																	
24'- 79.9 LB. - 7.00" FLANGE	29	0	0	0	15	0	0	14	0	0	28	0	0	0	0	0	14	0	20	2	2	0	8	1	1	8	0	20	2	0	0	10	1	1	10	0	0	12	2	0	0	6	1	1	6	0	0																																	

HOIST I-BEAM SIZES STANDARD	206CG 211CG 216CG 221CG 231CG 236CG 241CG 246CG 256CG 261CG 266CG 271CG 406CG 411CG 416CG 431CG 436CG 441CG 451CG 456CG 461CG 466CG 626CG																417G 437G 453G 469G 473G 477G 481G 606G 611G 616G 621G 636G 631G 641G 646G 651G 656G 661G 666G 671G 676G 681G 686G 1001G 1006G 1016G 1021G 1031G 1036G 1046G 1051G																421CG 446CG 466CG 471CG 476CG 481CG 606CG 611CG 616CG 621CG 631CG 636CG 641CG 646CG 651CG 656CG 661CG 666CG 1001CG 1006CG 1026CG 1031CG 1051CG 1056CG																1011G 1026G 1041G 1056G 1061G 1066G 1211G 1216G 1221G 1236G 1241G 1246G 1251G 1256G 1261G 1266G 1271G 1276G																1011CG 1016CG 1021CG 1036CG 1041CG 1046CG 1061CG 1066CG 1071CG 1501CG 1511CG 1521CG 1531CG 1541CG 1541G															
	NBR		NBR		A		B		C		D		NBR		NBR		A		B		C		D		NBR		NBR		A		B		C		D		NBR		NBR		A		B		C		D																																	
	WSHR	SPCR	W	S	W	S	W	S	W	S	W	S	WSHR	SPCR	W	S	W	S	WSHR	SPCR	W	S	W	S	WSHR	SPCR	W	S	W	S	WSHR	SPCR	W	S	W	S	WSHR	SPCR	W	S	W	S	WSHR	SPCR	W	S	W	S																																
5'- 10.0 LB. - 3.00" FLANGE	14	2	6	1	1	0	0	1	1	8																																																																						
6'- 12.5 LB. - 3.33" FLANGE	14	2	4	1	3	0	0	3	1	4	10	2	5	1	0	0	0	0	1	5	6	0	3	0	0	0	0	0	0	0	0	0	0	0	0	0	0	0	0	0	0	0	0	0	0	0	0	0	0	0	0																													
8'- 18.4 LB. - 4.00" FLANGE	14	2	2	1	5	0	0	4	1	3	10	2	4	1	1	0	0	1	1	4	6	0	2	0	1	0	0	0	1	0	0	0	0	0	0	0	0	0	0	0	0	0	0	0	0	0	0	0	0	0	0	0	0																											
9'- 21.8 LB. - 4.33" FLANGE	14	2	1	1	6	0	0	5	1	2	10	2	3	1	2	0	0	2	1	3	6	0	1	0	2	0	0	2	0	0	0	0	0	0	0	0	0	0	0	0	0	0	0	0	0	0	0	0	0	0	0	0	0																											
10'- 25.4 LB. - 4.66" FLANGE	14	2	0	0	7	1	1	7	0	0	10	2	2	1	3	0	0	3	1	2	6	0	0	0	3	0	0	0	0	0	0	0	0	0	0	0	0	0	0	0	0	0	0	0	0	0	0	0	0	0	0	0	0																											
12'- 31.8 LB. - 5.00" FLANGE	14	2	0	0	7	1	1	7	0	0	10	2	0	1	5	0	0	4	1	1	10	2	5	0	1	1	0	0	1	1	5	16	0	7	0	1	0	0	1	0	0	1	0	0	7	0	1	0	7	0	0	0	0																											
15'- 42.9 LB. - 5.50" FLANGE	14	2	0	0	7	1	1	7	0	0	10	2	0	1	5	0	0	4	1	1	10	2	5	0	1	1	0	0	5	12	2	3	1	3	0	0	1	3	16	0	5	0	3	0	0	2	0	6	0	6	0	6																												
18'- 54.7 LB. - 6.00" FLANGE	14	2	0	0	7	1	1	7	0	0	10	2	0	1	5	0	0	4	1	1	10	2	5	0	1	1	0	0	5	12	2	0	0	2	1	1	0	5	16	0	4	0	4	0	0	4	0	4	0	4	0	4																												
20'- 65.4 LB. - 6.25" FLANGE	14	2	0	0	7	1	1	7	0	0	10	2	0	1	5	0	0	4	1	1	10	2	5	0	1	1	0	0	5	12	2	0	0	2	1	1	2	0	2	16	0	3	0	5	0	0	5	0	3	0	3																													
24'- 79.9 LB. - 7.00" FLANGE	14	2	0	0	7	1	1	7	0	0	10	2	0	1	5	0	0	4	1	1	10	2	5	0	1	1	0	0	5	12	2	1	0	5	1	1	5	0	1	16	0	1	0	7	0	0	7	0	1	0	1																													

HOIST I-BEAM SIZES STANDARD	1201G 1206G 1226G 1231G 1501G 1511G 1521G 1531G																1601G 1611G 1621G 1631G 1641G 1651G 1661G 1671G 1681G 2001G 2011G 2021G 2031G 2041G 2051G 2061G 2071G 2081G 2401G 2411G 2421G 2431G 2441G 2451G 2461G 2471G 2481G																																															
	NBR		NBR		A		B		C		D		NBR		NBR		A		B		C		D		NBR		NBR		A		B		C		D		NBR		NBR		A		B		C		D																	
	WSHR	SPCR	W	S	W	S	W	S	W	S	W	S	WSHR	SPCR	W	S	W	S	WSHR	SPCR	W	S	W	S	WSHR	SPCR	W	S	W	S	WSHR	SPCR	W	S	W	S	WSHR	SPCR	W	S	W	S	WSHR	SPCR	W	S	W	S																
8'- 18.4 LB. - 4.00" FLANGE	14	2	2	0	5	1	1	4	0	3																																																						
9'- 21.8 LB. - 4.33" FLANGE	14	2	1	0	6	1	1	5	0	2																																																						
10'- 25.4 LB. - 4.66" FLANGE	14	2	1	0	6	1	1	6	0	1																																																						
12'- 31.8 LB. - 5.00" FLANGE	14	2	0	0	7	1	1	7	0	0																																																						
15'- 42.9 LB. - 5.50" FLANGE	10	4	4	0	5	2	2	4	0	5	12																																																					

PLAIN



SUSPENSION OF PLAIN TROLLEY

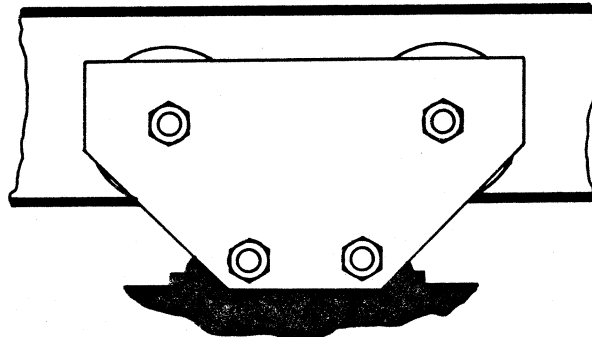
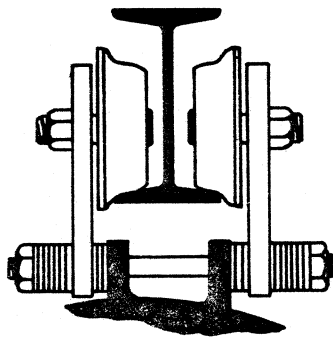

1. Inspect the trolley for any damage that may have occurred during shipment and remove the wooden block from between the wheels.

2. Since the trolley has been rigidly inspected and carefully adjusted for proper operation and fit to the I-beam specified on your order, very little adjustment, if any, need be made at installation. It is important that the trolley be assembled properly on the beam. If adjustment is necessary refer to the spacer washer chart on opposite page.

3. If the I-beam is open on one end it is not necessary to disassemble the trolley for installation. Simply raise the unit up to the I-beam and slide the trolley onto the flange. If the beam is not open follow the steps as listed below.

4. Remove the nuts, lockwashers and spacer washers from the double end studs on one side of the trolley. Remove the sideplate and then

raise the unit up to the beam.

5. Reassemble the trolley and tighten all the nuts securely. If the trolley is adjusted properly there will be approximately 1/8" between the flange of each wheel and the edge of the I-beam.

6. Check all hardware to make sure they are tight and that the hoist is securely fastened to the trolley. Then complete steps 3 thru 13 of the hoist installation procedures.

7. After all of the hoist installation and inspection procedures have been completed the trolley should be tested beginning with no load and working up to full load.

8. Push the trolley back and forth noticing that it tracks properly on the beam and that it runs freely without any sign of binding with the beam.

When Replacement Parts Are Needed, Order Only YALE[®] Factory Engineered Parts

AIR FLOW



AIR FLOW DIAGRAM CABLE KING AIR HOISTS

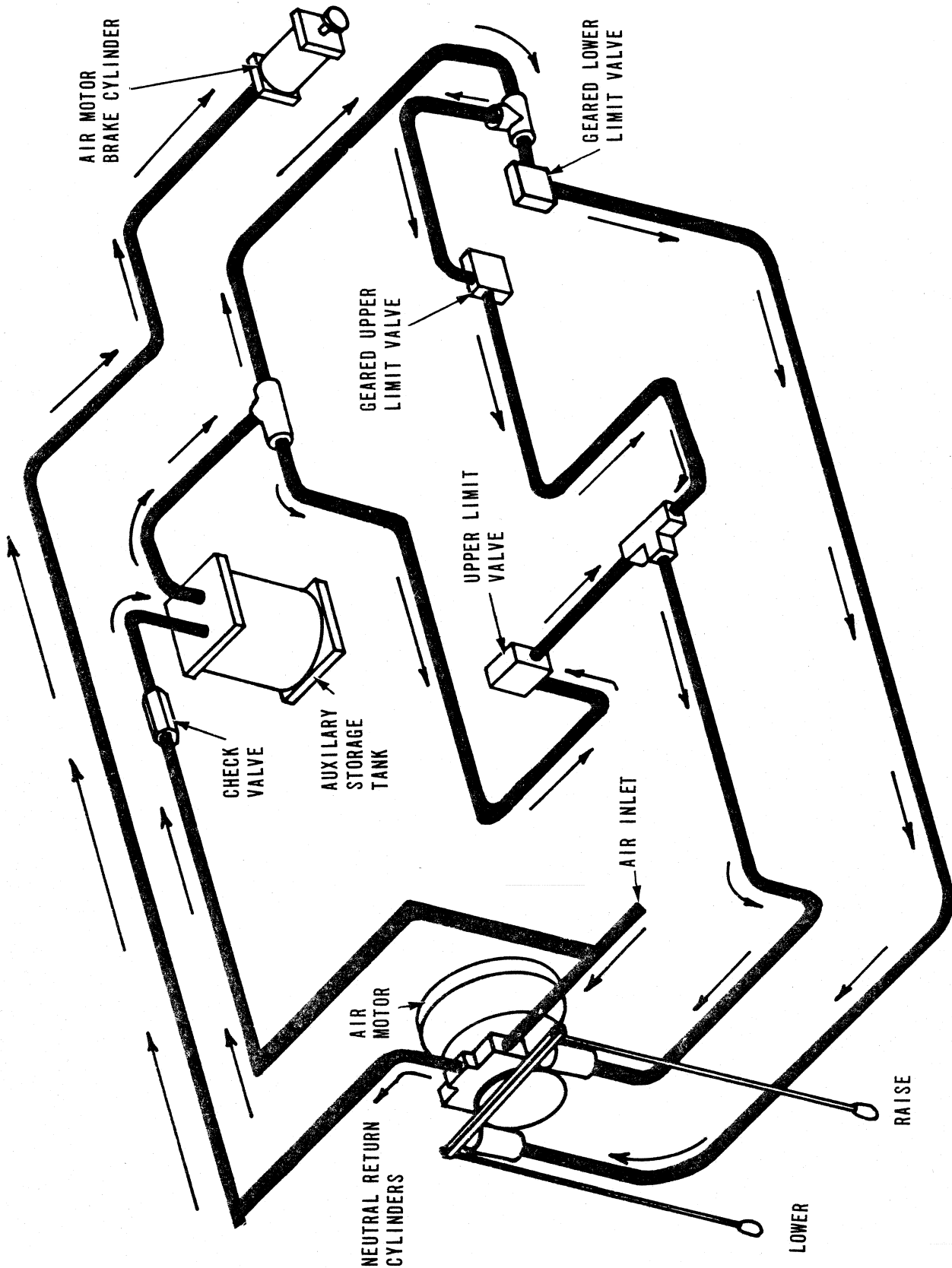

When Replacement Parts Are Needed, Order Only YALE[®] Factory Engineered Parts



SCHEMATIC FOR CLOSE HEADROOM
AIR CABLE KING HOIST

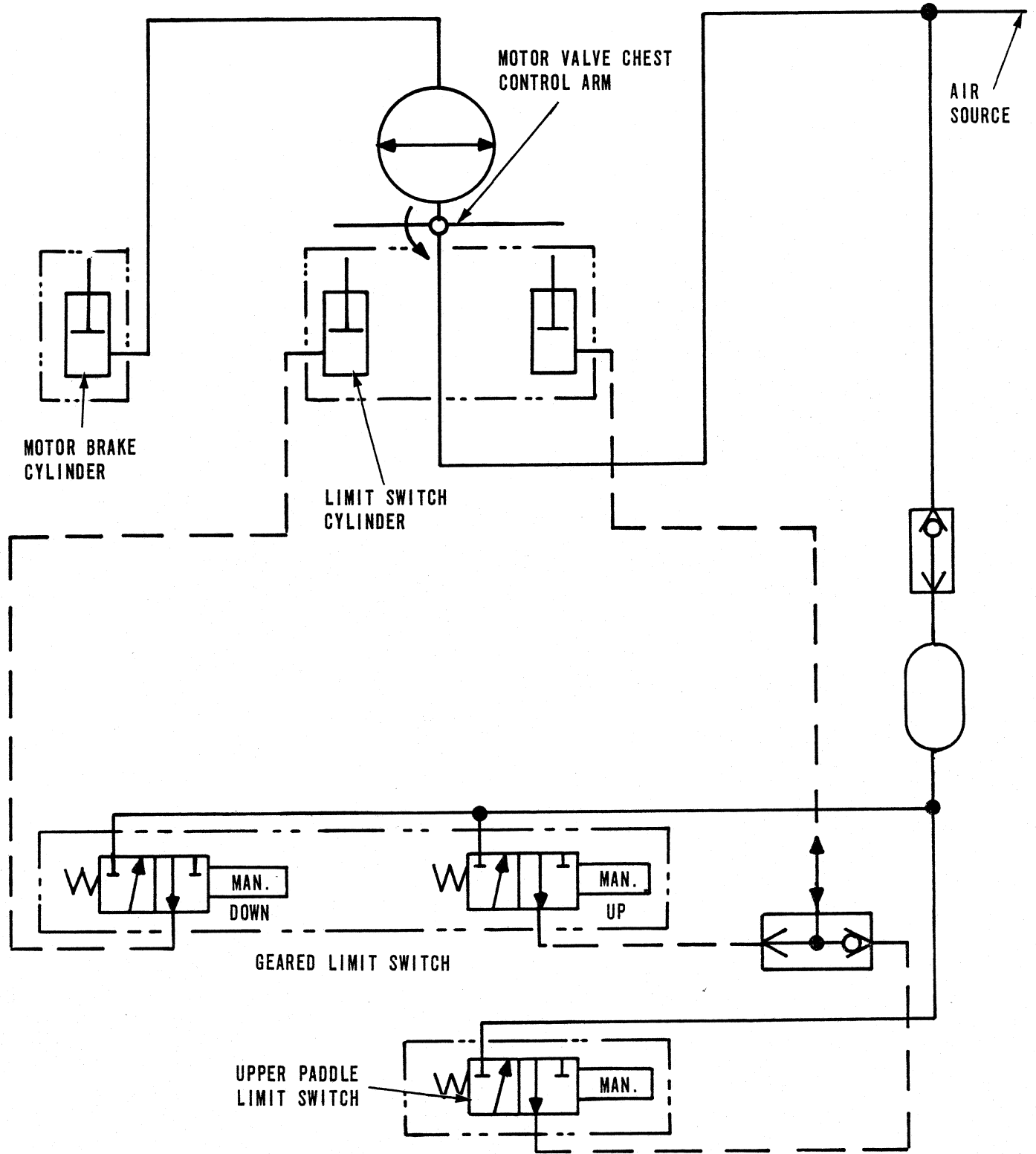

When Replacement Parts Are Needed, Order Only YALE[®] Factory Engineered Parts

SCHEMATIC



SCHEMATIC FOR STANDARD HEADROOM AIR CABLE KING HOIST

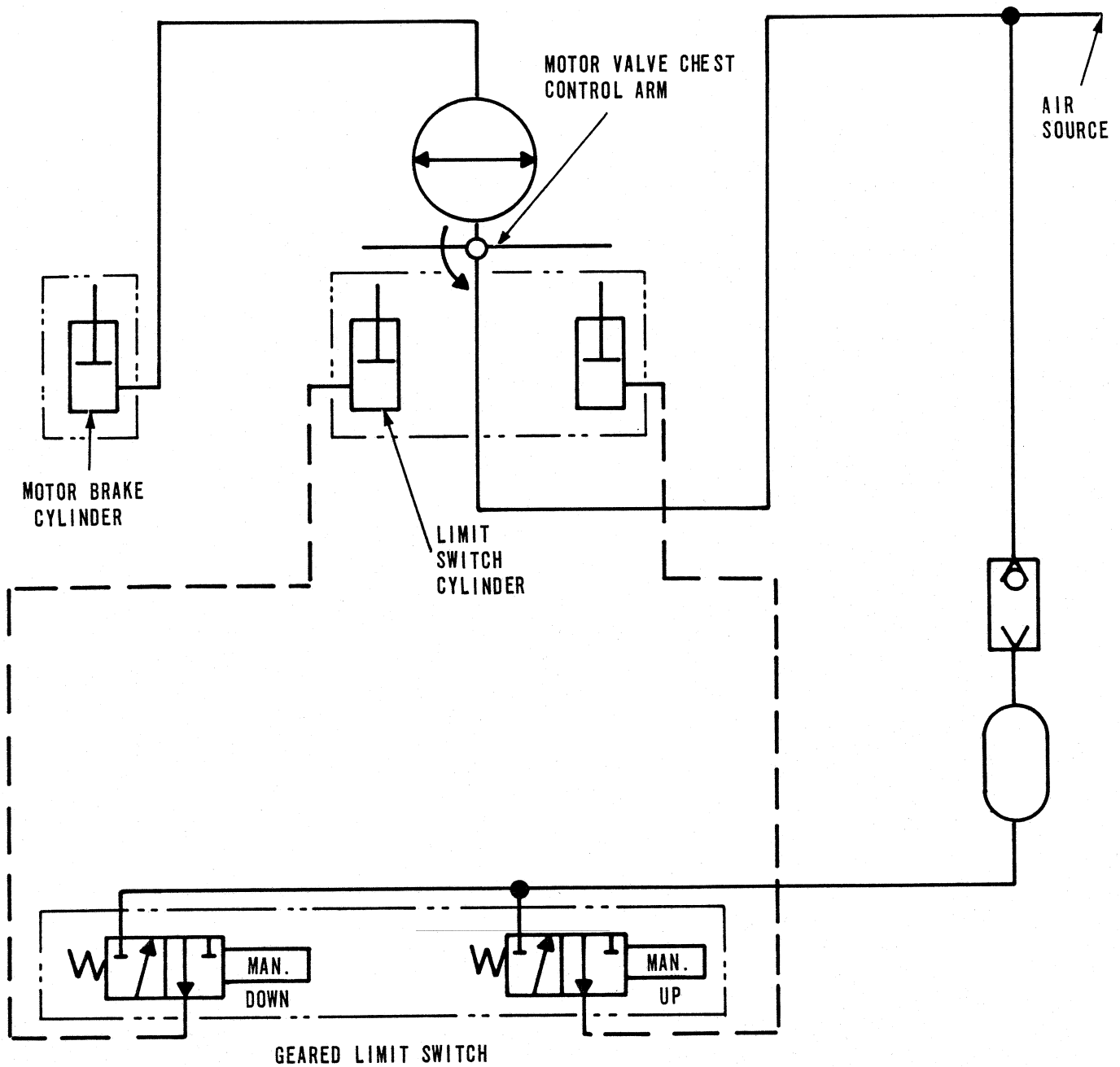

When Replacement Parts Are Needed, Order Only YALE[®] Factory Engineered Parts

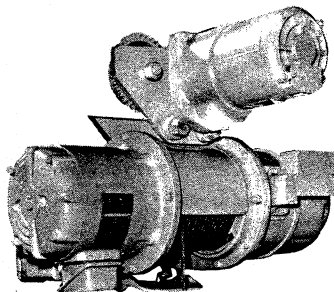
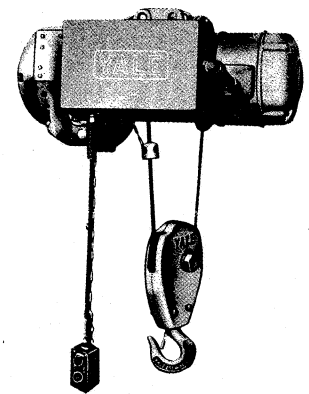
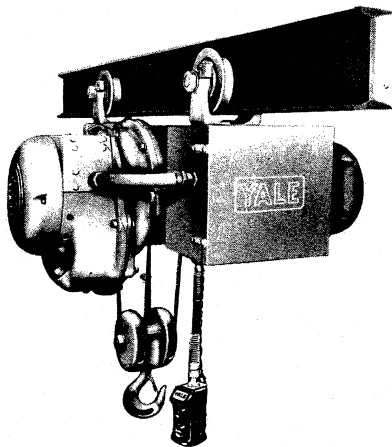
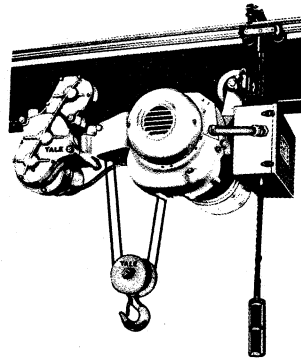
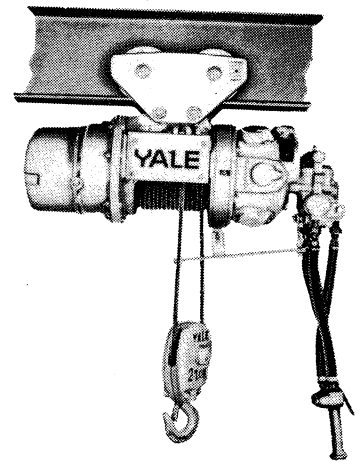
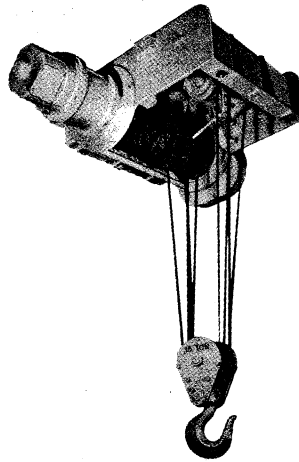
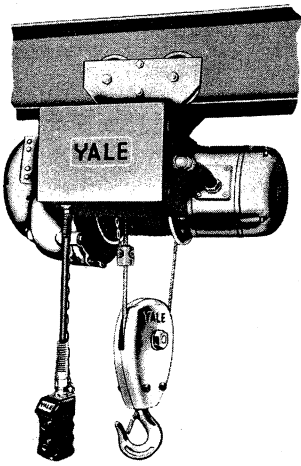

HOISTING EQUIPMENT DIVISION

FORREST CITY, ARKANSAS 72335

WARRANTY: Eaton Yale & Towne Inc. warrants to the original using purchaser thereof that hoisting equipment and parts thereof furnished by its Hoisting Equipment Division will, when properly assembled, (if such is required) and installed by such purchaser, be and remain free under normal conditions of use and operation, from all malfunctions arising out of defects in material or workmanship for a period of ONE YEAR from the date of delivery to such original using purchaser. This warranty is subject to the conditions noted herein.

Such warranty shall not apply to hoists, hoisting equipment or parts thereof subjected to operation in excess of design limitations, negligent maintenance, or abuse or damage by casualty.

All warranty claims shall be made to the Hoisting Equipment Division at Highway #1 North, Forrest City, Arkansas 72335, and shall be supported by satisfactory evidence in respect of conditions herein noted. As a condition precedent to the allowance of such claim, the hoist, hoisting equipment or part involved shall, if requested by the Hoisting

Equipment Division, be returned by freight prepaid to such division for examination. Hoisting Equipment Division reserves the right in its sole discretion to repair or replace, f.o.b. Forrest City, Arkansas, any hoist, hoisting equipment, or parts found to be defective upon examination by its authorized personnel; and with respect to parts not of its own manufacture, such division limits its obligation hereunder to the adjustment, if any, obtained from the manufacturer thereof. Such obligation shall be the limit of Eaton Yale & Towne Inc.'s liability under this warranty.

We undertake no responsibility for work done or expense incurred in connection with repair or replacement except on specific authority of the Hoisting Equipment Division, and that there is NO WARRANTY OF FITNESS FOR A PARTICULAR PURPOSE.

Except as stated herein, subject to the conditions noted, Eaton Yale & Towne Inc. makes nor authorizes to be made any other warranty expressed or implied on b. its Hoisting Equipment Division.

EATON Materials Handling