

A16 CONTROL PANEL

| WIRE # | DEVICE CONNECTED |
|--------|---------------------|
| L100 | x16-100 |
| L101 | x16-101 |
| L110 | A110 |
| L111 | A110 |
| L117 | A110 |
| L210 | A275, S265, S220-S2 |
| L211 | A275 |
| L212 | A275 |
| L215 | S263 |
| L219 | A275 |
| L236 | S260 |
| L237 | S260 |
| L238 | S260 |
| L239 | S260 |
| L239 | S260 |
| L411 | A110 |
| L412 | A110 |
| L415 | A110 |
| L423 | A110 |

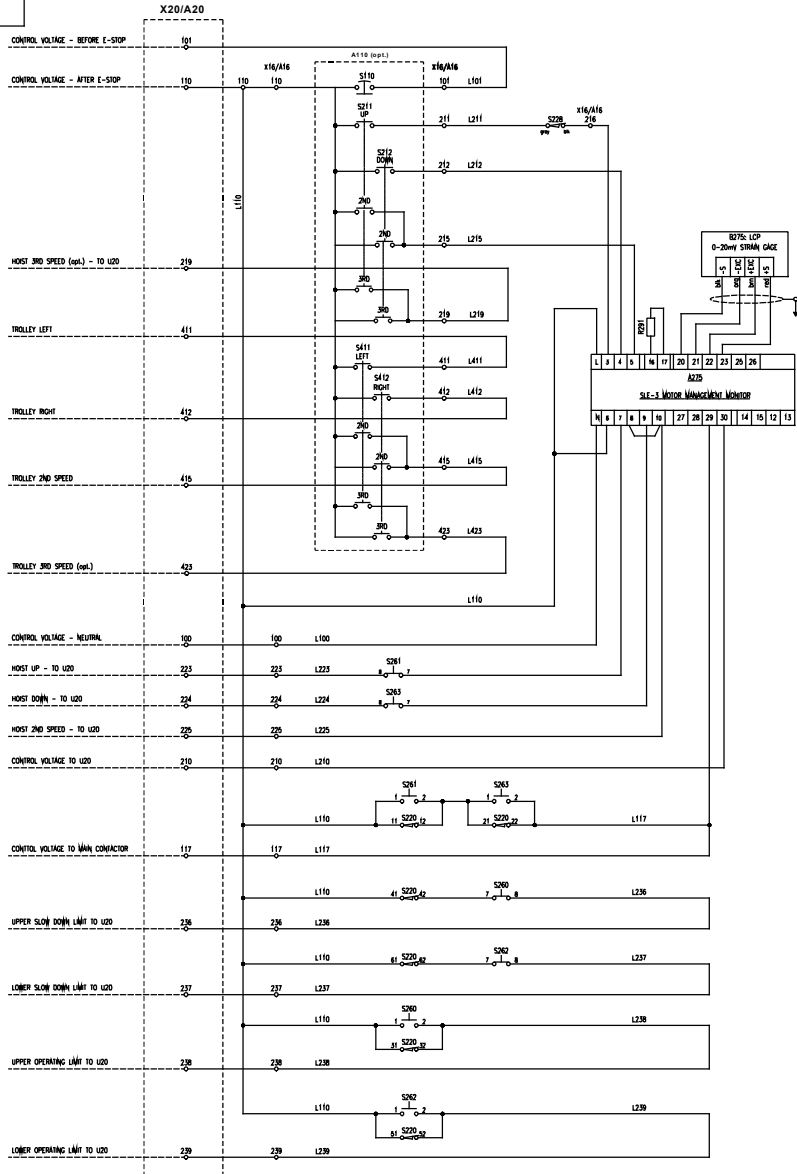

| NO. | DESCRIPTION | DATE | BY |
|-----|-------------------------|------|----|
| 1 | ISSUED FOR CONSTRUCTION | | |
| 2 | ISSUED FOR CONSTRUCTION | | |
| 3 | ISSUED FOR CONSTRUCTION | | |
| 4 | ISSUED FOR CONSTRUCTION | | |
| 5 | ISSUED FOR CONSTRUCTION | | |
| 6 | ISSUED FOR CONSTRUCTION | | |
| 7 | ISSUED FOR CONSTRUCTION | | |
| 8 | ISSUED FOR CONSTRUCTION | | |
| 9 | ISSUED FOR CONSTRUCTION | | |
| 10 | ISSUED FOR CONSTRUCTION | | |
| 11 | ISSUED FOR CONSTRUCTION | | |
| 12 | ISSUED FOR CONSTRUCTION | | |
| 13 | ISSUED FOR CONSTRUCTION | | |
| 14 | ISSUED FOR CONSTRUCTION | | |
| 15 | ISSUED FOR CONSTRUCTION | | |
| 16 | ISSUED FOR CONSTRUCTION | | |
| 17 | ISSUED FOR CONSTRUCTION | | |
| 18 | ISSUED FOR CONSTRUCTION | | |
| 19 | ISSUED FOR CONSTRUCTION | | |
| 20 | ISSUED FOR CONSTRUCTION | | |
| 21 | ISSUED FOR CONSTRUCTION | | |
| 22 | ISSUED FOR CONSTRUCTION | | |
| 23 | ISSUED FOR CONSTRUCTION | | |
| 24 | ISSUED FOR CONSTRUCTION | | |
| 25 | ISSUED FOR CONSTRUCTION | | |
| 26 | ISSUED FOR CONSTRUCTION | | |
| 27 | ISSUED FOR CONSTRUCTION | | |
| 28 | ISSUED FOR CONSTRUCTION | | |
| 29 | ISSUED FOR CONSTRUCTION | | |
| 30 | ISSUED FOR CONSTRUCTION | | |
| 31 | ISSUED FOR CONSTRUCTION | | |
| 32 | ISSUED FOR CONSTRUCTION | | |
| 33 | ISSUED FOR CONSTRUCTION | | |
| 34 | ISSUED FOR CONSTRUCTION | | |
| 35 | ISSUED FOR CONSTRUCTION | | |
| 36 | ISSUED FOR CONSTRUCTION | | |
| 37 | ISSUED FOR CONSTRUCTION | | |
| 38 | ISSUED FOR CONSTRUCTION | | |
| 39 | ISSUED FOR CONSTRUCTION | | |
| 40 | ISSUED FOR CONSTRUCTION | | |
| 41 | ISSUED FOR CONSTRUCTION | | |
| 42 | ISSUED FOR CONSTRUCTION | | |
| 43 | ISSUED FOR CONSTRUCTION | | |
| 44 | ISSUED FOR CONSTRUCTION | | |
| 45 | ISSUED FOR CONSTRUCTION | | |
| 46 | ISSUED FOR CONSTRUCTION | | |
| 47 | ISSUED FOR CONSTRUCTION | | |
| 48 | ISSUED FOR CONSTRUCTION | | |
| 49 | ISSUED FOR CONSTRUCTION | | |
| 50 | ISSUED FOR CONSTRUCTION | | |
| 51 | ISSUED FOR CONSTRUCTION | | |
| 52 | ISSUED FOR CONSTRUCTION | | |
| 53 | ISSUED FOR CONSTRUCTION | | |
| 54 | ISSUED FOR CONSTRUCTION | | |
| 55 | ISSUED FOR CONSTRUCTION | | |
| 56 | ISSUED FOR CONSTRUCTION | | |
| 57 | ISSUED FOR CONSTRUCTION | | |
| 58 | ISSUED FOR CONSTRUCTION | | |
| 59 | ISSUED FOR CONSTRUCTION | | |
| 60 | ISSUED FOR CONSTRUCTION | | |
| 61 | ISSUED FOR CONSTRUCTION | | |
| 62 | ISSUED FOR CONSTRUCTION | | |
| 63 | ISSUED FOR CONSTRUCTION | | |
| 64 | ISSUED FOR CONSTRUCTION | | |
| 65 | ISSUED FOR CONSTRUCTION | | |
| 66 | ISSUED FOR CONSTRUCTION | | |
| 67 | ISSUED FOR CONSTRUCTION | | |
| 68 | ISSUED FOR CONSTRUCTION | | |
| 69 | ISSUED FOR CONSTRUCTION | | |
| 70 | ISSUED FOR CONSTRUCTION | | |
| 71 | ISSUED FOR CONSTRUCTION | | |
| 72 | ISSUED FOR CONSTRUCTION | | |
| 73 | ISSUED FOR CONSTRUCTION | | |
| 74 | ISSUED FOR CONSTRUCTION | | |
| 75 | ISSUED FOR CONSTRUCTION | | |
| 76 | ISSUED FOR CONSTRUCTION | | |
| 77 | ISSUED FOR CONSTRUCTION | | |
| 78 | ISSUED FOR CONSTRUCTION | | |
| 79 | ISSUED FOR CONSTRUCTION | | |
| 80 | ISSUED FOR CONSTRUCTION | | |
| 81 | ISSUED FOR CONSTRUCTION | | |
| 82 | ISSUED FOR CONSTRUCTION | | |
| 83 | ISSUED FOR CONSTRUCTION | | |
| 84 | ISSUED FOR CONSTRUCTION | | |
| 85 | ISSUED FOR CONSTRUCTION | | |
| 86 | ISSUED FOR CONSTRUCTION | | |
| 87 | ISSUED FOR CONSTRUCTION | | |
| 88 | ISSUED FOR CONSTRUCTION | | |
| 89 | ISSUED FOR CONSTRUCTION | | |
| 90 | ISSUED FOR CONSTRUCTION | | |
| 91 | ISSUED FOR CONSTRUCTION | | |
| 92 | ISSUED FOR CONSTRUCTION | | |
| 93 | ISSUED FOR CONSTRUCTION | | |
| 94 | ISSUED FOR CONSTRUCTION | | |
| 95 | ISSUED FOR CONSTRUCTION | | |
| 96 | ISSUED FOR CONSTRUCTION | | |
| 97 | ISSUED FOR CONSTRUCTION | | |
| 98 | ISSUED FOR CONSTRUCTION | | |
| 99 | ISSUED FOR CONSTRUCTION | | |
| 100 | ISSUED FOR CONSTRUCTION | | |

OMPO
WARRANTY
 1 YEAR WARRANTY
 2 YEAR WARRANTY
 3 YEAR WARRANTY
 4 YEAR WARRANTY
 5 YEAR WARRANTY
 6 YEAR WARRANTY
 7 YEAR WARRANTY
 8 YEAR WARRANTY
 9 YEAR WARRANTY
 10 YEAR WARRANTY
 11 YEAR WARRANTY
 12 YEAR WARRANTY
 13 YEAR WARRANTY
 14 YEAR WARRANTY
 15 YEAR WARRANTY
 16 YEAR WARRANTY
 17 YEAR WARRANTY
 18 YEAR WARRANTY
 19 YEAR WARRANTY
 20 YEAR WARRANTY
 21 YEAR WARRANTY
 22 YEAR WARRANTY
 23 YEAR WARRANTY
 24 YEAR WARRANTY
 25 YEAR WARRANTY
 26 YEAR WARRANTY
 27 YEAR WARRANTY
 28 YEAR WARRANTY
 29 YEAR WARRANTY
 30 YEAR WARRANTY
 31 YEAR WARRANTY
 32 YEAR WARRANTY
 33 YEAR WARRANTY
 34 YEAR WARRANTY
 35 YEAR WARRANTY
 36 YEAR WARRANTY
 37 YEAR WARRANTY
 38 YEAR WARRANTY
 39 YEAR WARRANTY
 40 YEAR WARRANTY
 41 YEAR WARRANTY
 42 YEAR WARRANTY
 43 YEAR WARRANTY
 44 YEAR WARRANTY
 45 YEAR WARRANTY
 46 YEAR WARRANTY
 47 YEAR WARRANTY
 48 YEAR WARRANTY
 49 YEAR WARRANTY
 50 YEAR WARRANTY
 51 YEAR WARRANTY
 52 YEAR WARRANTY
 53 YEAR WARRANTY
 54 YEAR WARRANTY
 55 YEAR WARRANTY
 56 YEAR WARRANTY
 57 YEAR WARRANTY
 58 YEAR WARRANTY
 59 YEAR WARRANTY
 60 YEAR WARRANTY
 61 YEAR WARRANTY
 62 YEAR WARRANTY
 63 YEAR WARRANTY
 64 YEAR WARRANTY
 65 YEAR WARRANTY
 66 YEAR WARRANTY
 67 YEAR WARRANTY
 68 YEAR WARRANTY
 69 YEAR WARRANTY
 70 YEAR WARRANTY
 71 YEAR WARRANTY
 72 YEAR WARRANTY
 73 YEAR WARRANTY
 74 YEAR WARRANTY
 75 YEAR WARRANTY
 76 YEAR WARRANTY
 77 YEAR WARRANTY
 78 YEAR WARRANTY
 79 YEAR WARRANTY
 80 YEAR WARRANTY
 81 YEAR WARRANTY
 82 YEAR WARRANTY
 83 YEAR WARRANTY
 84 YEAR WARRANTY
 85 YEAR WARRANTY
 86 YEAR WARRANTY
 87 YEAR WARRANTY
 88 YEAR WARRANTY
 89 YEAR WARRANTY
 90 YEAR WARRANTY
 91 YEAR WARRANTY
 92 YEAR WARRANTY
 93 YEAR WARRANTY
 94 YEAR WARRANTY
 95 YEAR WARRANTY
 96 YEAR WARRANTY
 97 YEAR WARRANTY
 98 YEAR WARRANTY
 99 YEAR WARRANTY
 100 YEAR WARRANTY

SYMBOL DESIGNATIONS

| | |
|------|-----------------------------|
| A110 | PUSHBUTTON PENDANT |
| A275 | SLEW MOTOR MOTOR |
| S260 | GEARED LIMIT SWITCH |
| S263 | GEARED LIMIT SWITCH |
| S265 | GEARED LIMIT SWITCH |
| S270 | EMERGENCY UPPER LIMIT RESET |
| S271 | EMERGENCY LOWER LIMIT RESET |
| S272 | EMERGENCY LOWER LIMIT RESET |
| S273 | EMERGENCY LOWER LIMIT RESET |
| S274 | EMERGENCY LOWER LIMIT RESET |
| S275 | EMERGENCY LOWER LIMIT RESET |
| S276 | EMERGENCY LOWER LIMIT RESET |
| S277 | EMERGENCY LOWER LIMIT RESET |
| S278 | EMERGENCY LOWER LIMIT RESET |
| S279 | EMERGENCY LOWER LIMIT RESET |
| S280 | EMERGENCY LOWER LIMIT RESET |
| S281 | EMERGENCY LOWER LIMIT RESET |
| S282 | EMERGENCY LOWER LIMIT RESET |
| S283 | EMERGENCY LOWER LIMIT RESET |
| S284 | EMERGENCY LOWER LIMIT RESET |
| S285 | EMERGENCY LOWER LIMIT RESET |
| S286 | EMERGENCY LOWER LIMIT RESET |
| S287 | EMERGENCY LOWER LIMIT RESET |
| S288 | EMERGENCY LOWER LIMIT RESET |
| S289 | EMERGENCY LOWER LIMIT RESET |
| S290 | EMERGENCY LOWER LIMIT RESET |
| S291 | EMERGENCY LOWER LIMIT RESET |
| S292 | EMERGENCY LOWER LIMIT RESET |
| S293 | EMERGENCY LOWER LIMIT RESET |
| S294 | EMERGENCY LOWER LIMIT RESET |
| S295 | EMERGENCY LOWER LIMIT RESET |
| S296 | EMERGENCY LOWER LIMIT RESET |
| S297 | EMERGENCY LOWER LIMIT RESET |
| S298 | EMERGENCY LOWER LIMIT RESET |
| S299 | EMERGENCY LOWER LIMIT RESET |
| S300 | EMERGENCY LOWER LIMIT RESET |
| S301 | EMERGENCY LOWER LIMIT RESET |
| S302 | EMERGENCY LOWER LIMIT RESET |
| S303 | EMERGENCY LOWER LIMIT RESET |
| S304 | EMERGENCY LOWER LIMIT RESET |
| S305 | EMERGENCY LOWER LIMIT RESET |
| S306 | EMERGENCY LOWER LIMIT RESET |
| S307 | EMERGENCY LOWER LIMIT RESET |
| S308 | EMERGENCY LOWER LIMIT RESET |
| S309 | EMERGENCY LOWER LIMIT RESET |
| S310 | EMERGENCY LOWER LIMIT RESET |
| S311 | EMERGENCY LOWER LIMIT RESET |
| S312 | EMERGENCY LOWER LIMIT RESET |
| S313 | EMERGENCY LOWER LIMIT RESET |
| S314 | EMERGENCY LOWER LIMIT RESET |
| S315 | EMERGENCY LOWER LIMIT RESET |
| S316 | EMERGENCY LOWER LIMIT RESET |
| S317 | EMERGENCY LOWER LIMIT RESET |
| S318 | EMERGENCY LOWER LIMIT RESET |
| S319 | EMERGENCY LOWER LIMIT RESET |
| S320 | EMERGENCY LOWER LIMIT RESET |
| S321 | EMERGENCY LOWER LIMIT RESET |
| S322 | EMERGENCY LOWER LIMIT RESET |
| S323 | EMERGENCY LOWER LIMIT RESET |
| S324 | EMERGENCY LOWER LIMIT RESET |
| S325 | EMERGENCY LOWER LIMIT RESET |
| S326 | EMERGENCY LOWER LIMIT RESET |
| S327 | EMERGENCY LOWER LIMIT RESET |
| S328 | EMERGENCY LOWER LIMIT RESET |
| S329 | EMERGENCY LOWER LIMIT RESET |
| S330 | EMERGENCY LOWER LIMIT RESET |
| S331 | EMERGENCY LOWER LIMIT RESET |
| S332 | EMERGENCY LOWER LIMIT RESET |
| S333 | EMERGENCY LOWER LIMIT RESET |
| S334 | EMERGENCY LOWER LIMIT RESET |
| S335 | EMERGENCY LOWER LIMIT RESET |
| S336 | EMERGENCY LOWER LIMIT RESET |
| S337 | EMERGENCY LOWER LIMIT RESET |
| S338 | EMERGENCY LOWER LIMIT RESET |
| S339 | EMERGENCY LOWER LIMIT RESET |
| S340 | EMERGENCY LOWER LIMIT RESET |
| S341 | EMERGENCY LOWER LIMIT RESET |
| S342 | EMERGENCY LOWER LIMIT RESET |
| S343 | EMERGENCY LOWER LIMIT RESET |
| S344 | EMERGENCY LOWER LIMIT RESET |
| S345 | EMERGENCY LOWER LIMIT RESET |
| S346 | EMERGENCY LOWER LIMIT RESET |
| S347 | EMERGENCY LOWER LIMIT RESET |
| S348 | EMERGENCY LOWER LIMIT RESET |
| S349 | EMERGENCY LOWER LIMIT RESET |
| S350 | EMERGENCY LOWER LIMIT RESET |
| S351 | EMERGENCY LOWER LIMIT RESET |
| S352 | EMERGENCY LOWER LIMIT RESET |
| S353 | EMERGENCY LOWER LIMIT RESET |
| S354 | EMERGENCY LOWER LIMIT RESET |
| S355 | EMERGENCY LOWER LIMIT RESET |
| S356 | EMERGENCY LOWER LIMIT RESET |
| S357 | EMERGENCY LOWER LIMIT RESET |
| S358 | EMERGENCY LOWER LIMIT RESET |
| S359 | EMERGENCY LOWER LIMIT RESET |
| S360 | EMERGENCY LOWER LIMIT RESET |
| S361 | EMERGENCY LOWER LIMIT RESET |
| S362 | EMERGENCY LOWER LIMIT RESET |
| S363 | EMERGENCY LOWER LIMIT RESET |
| S364 | EMERGENCY LOWER LIMIT RESET |
| S365 | EMERGENCY LOWER LIMIT RESET |
| S366 | EMERGENCY LOWER LIMIT RESET |
| S367 | EMERGENCY LOWER LIMIT RESET |
| S368 | EMERGENCY LOWER LIMIT RESET |
| S369 | EMERGENCY LOWER LIMIT RESET |
| S370 | EMERGENCY LOWER LIMIT RESET |
| S371 | EMERGENCY LOWER LIMIT RESET |
| S372 | EMERGENCY LOWER LIMIT RESET |
| S373 | EMERGENCY LOWER LIMIT RESET |
| S374 | EMERGENCY LOWER LIMIT RESET |
| S375 | EMERGENCY LOWER LIMIT RESET |
| S376 | EMERGENCY LOWER LIMIT RESET |
| S377 | EMERGENCY LOWER LIMIT RESET |
| S378 | EMERGENCY LOWER LIMIT RESET |
| S379 | EMERGENCY LOWER LIMIT RESET |
| S380 | EMERGENCY LOWER LIMIT RESET |
| S381 | EMERGENCY LOWER LIMIT RESET |
| S382 | EMERGENCY LOWER LIMIT RESET |
| S383 | EMERGENCY LOWER LIMIT RESET |
| S384 | EMERGENCY LOWER LIMIT RESET |
| S385 | EMERGENCY LOWER LIMIT RESET |
| S386 | EMERGENCY LOWER LIMIT RESET |
| S387 | EMERGENCY LOWER LIMIT RESET |
| S388 | EMERGENCY LOWER LIMIT RESET |
| S389 | EMERGENCY LOWER LIMIT RESET |
| S390 | EMERGENCY LOWER LIMIT RESET |
| S391 | EMERGENCY LOWER LIMIT RESET |
| S392 | EMERGENCY LOWER LIMIT RESET |
| S393 | EMERGENCY LOWER LIMIT RESET |
| S394 | EMERGENCY LOWER LIMIT RESET |
| S395 | EMERGENCY LOWER LIMIT RESET |
| S396 | EMERGENCY LOWER LIMIT RESET |
| S397 | EMERGENCY LOWER LIMIT RESET |
| S398 | EMERGENCY LOWER LIMIT RESET |
| S399 | EMERGENCY LOWER LIMIT RESET |
| S400 | EMERGENCY LOWER LIMIT RESET |

S270 - GEARED LIMIT SWITCH

| LEARN | FUNCTION | CONTACTS |
|-------|----------------------------|----------|
| S1 | EMERGENCY HOST UPPER LIMIT | 11-17 |
| S2 | EMERGENCY HOST LOWER LIMIT | 21-27 |
| S3 | OPERATING UPPER LIMIT | 31-37 |
| S4 | OPERATING LOWER LIMIT | 41-47 |
| S5 | UPPER SLOW DOWN LIMIT | 51-57 |
| S6 | LOWER SLOW DOWN LIMIT | 61-67 |



WARNINGS:
 THIS EQUIPMENT MUST BE EFFECTIVELY GROUNDED
 ACCORDING TO APPLICABLE CODES.
ADVERTISMENT:
 ALL EQUIPMENT MUST BE USED IN ACCORDANCE WITH THE INSTRUCTIONS ON THE EQUIPMENT.
 FIRST USED ON PROJECT ONE