

79693 – PNEUMATIC TWO BUTTON HANDLE ASSEMBLY FOR UP/DOWN USING TWO PILOT SIGNALS WITH TRIGGER

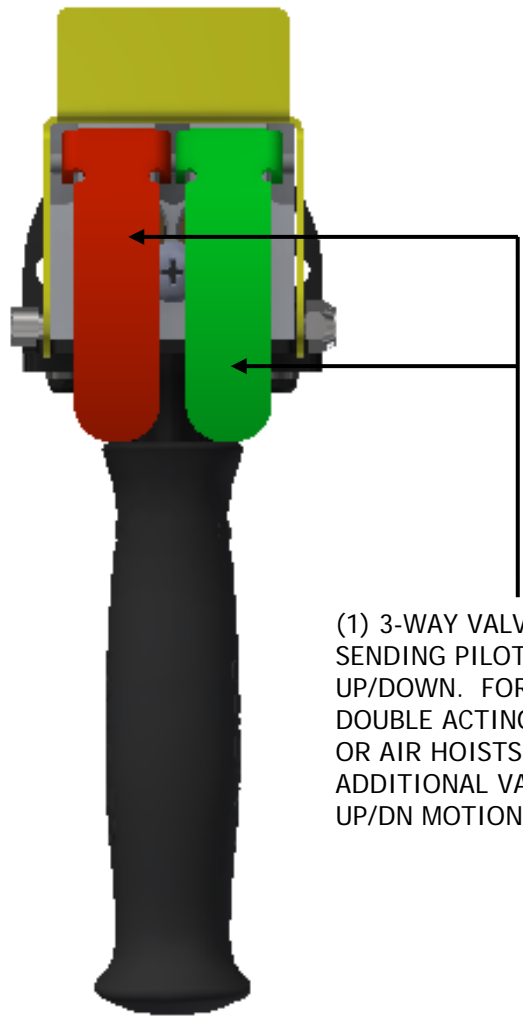

(1) 3-WAY VALVE FOR SENDING PILOT SIGNALS FOR UP/DOWN. FOR USE WITH DOUBLE ACTING CYLINDERS OR AIR HOISTS THAT USE AN ADDITIONAL VALVE FOR UP/DN MOTION

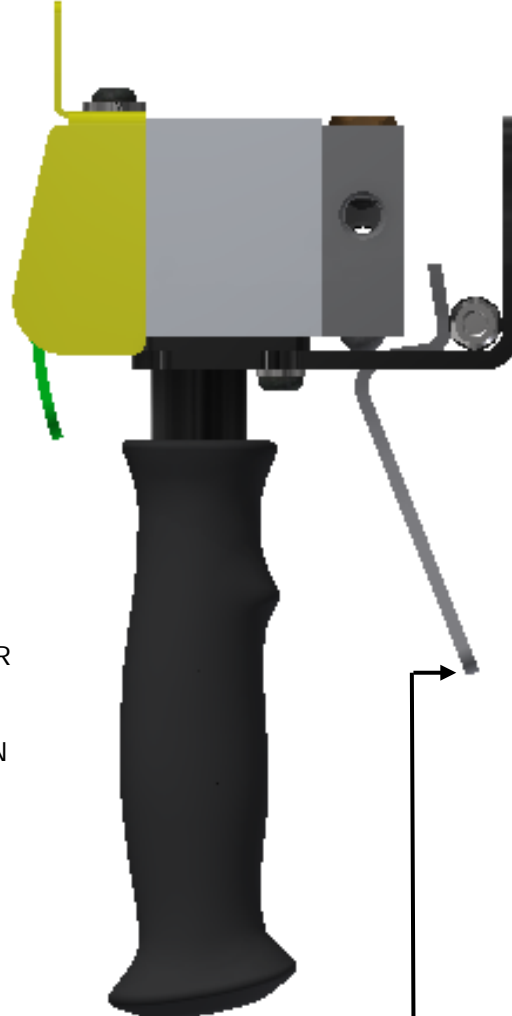

TRIGGER: 3-WAY VALVE USED FOR SENDING 1 PILOT SIGNAL

- TEMPERATURE RANGE: 32 TO 125 DEGREES F
- MAXIMUM PRESSURE: 100 PSI
- PORT 1: 1/4" NPT PILOT SIGNAL
- PORT 2: 1/4" NPT AIR SUPPLY
- PORT 3: 1/4" NPT PILOT SIGNAL
- TRIGGER BLOCK PORTS
 - PORT 1: 1/8" NPT AIR SUPPLY
 - PORT 2: 1/8" NPT PILOT SIGNAL
- HARDWARE TO BE SNUG TIGHT
- REQUIRES CLEAN DRY AIR

